

Public Disclosure Authorized

Public Disclosure Authorized

Public Disclosure Authorized

Public Disclosure Authorized

Off-Grid Solar Market Trends Report 2022: State of the Sector



Copyright

© 2022 October | International Bank for Reconstruction and Development / The World Bank 1818 H Street NW, Washington, DC 20433 Telephone: 202-473-1000; Internet: www.worldbank.org

The material in this work is subject to copyright. Because the World Bank encourages dissemination of its knowledge, this work may be reproduced, in whole or in part, for noncommercial purposes if full attribution to this work is given. Any queries on rights and licenses, including subsidiary rights, should be addressed to World Bank Publications, World Bank Group, 1818 H Street NW, Washington, DC 20433, USA; fax: +1-202-522-2625; e-mail: pubrights@worldbank.org.

Lighting Global/ESMAP, GOGLA, Efficiency For Access, Open Capital Advisors (2022), Off-Grid Solar Market Trends Report 2022: State of the Sector. Washington, DC: World Bank.

The World Bank does not necessarily own each component of the content contained within the work and does not warrant that the use of any third-party owned individual component or part contained in the work will not infringe on the rights of those third parties. If you wish to reuse a component of the work, it is your responsibility to determine whether permission is needed for that reuse and to obtain permission from the copyright owner. Examples of components can include, but are not limited to, tables, figures, or images.

Disclaimer

The conclusions and judgments contained in this report should not be attributed to, and do not necessarily represent the views of IFC or its Board of Directors, the World Bank or its Executive Directors, Efficiency for Access, or the countries they represent. IFC, World Bank and Efficiency for Access do not guarantee the accuracy of the data in this publication and accept no responsibility for any consequences of their use. The information contained in this publication is derived from carefully selected sources that are believed to be reasonable. GOGLA and Open Capital Advisors do not guarantee its accuracy or completeness and nothing in this document shall be construed to be a representation of such a guarantee. Any opinions expressed reflect the current judgment of the authors of the relevant article or features and do not necessarily reflect the opinion of GOGLA and Open Capital Advisors, Efficiency for Access, the IFC, or the World Bank. The opinions presented are subject to change without notice. GOGLA, Open Capital Advisors, Efficiency for Access the IFC, or the World Bank accept no responsibility for any liability arising from the use of this document or its contents.

Production Credits

Production Editor | GOGLA

Designer | Future by Design (www.futurebydesign.studio)

Images | Cover: Power Africa

All images remain the sole property of their source and may not be used for any purpose without written permission from the source.

This report is produced by Lighting Global/ESMAP, the International Finance Corporation, Efficiency for Access Coalition, GOGLA and Open Capital Advisors.

Off-Grid Solar Market Trends Report 2022:

State of the Sector



Foreword

The previous edition of our Off-Grid Solar Market Trends Report (MTR) was launched at the Global Off-Grid Solar Forum & Expo in Nairobi, Kenya in February 2020. The COVID-19 pandemic was declared only one month later, and within a few weeks, much of the world went into lockdown.

Before the pandemic, the off-grid solar (OGS) industry was experiencing double-digit growth. Over a decade of innovation and investment has created a strong core of products that have reached maturity, from solar energy kits to productive use appliances. These technologies have been embraced globally as essential tools in the fight to eliminate energy poverty and achieve a faster, more equitable clean energy transition.

However, the COVID-19 pandemic has presented major challenges for the industry and society as a whole. Millions of people were pushed, or pushed further, into poverty due to falling incomes, higher cost of living, and supply chain disruptions. Off-grid solar companies were confronted with price increases for raw materials and reduced incomes of their – often rural and relatively poor – customer base. Safety precautions made it difficult to connect with customers and partners, and investment was more difficult to access for many companies.

The pandemic has had a considerable adverse impact on markets, but the industry has also shown resilience. Many governments declared off-grid solar an essential service, allowing companies to operate even during strict lockdowns. Despite hardship, many customers prioritized energy spending, demonstrating the importance of electricity access and the benefits that OGS products provide.

As the pandemic abates and lockdowns are mostly lifted, the industry is showing early signs of a recovery. Sales numbers are increasing again, companies are expanding their services beyond energy, and 2021 recorded an all-time high of \$457 million investment, with 2022 set to be another record-breaking year. New technology segments are emerging that integrate low voltage power and appliances to strengthen the grid, and there is growing support from governments and donors to ensure that no one is left behind.

After a period of unprecedented shocks, the 2022 MTR provides in-depth insight into the latest key market dynamics and trends. The report is, for the first time, split into two parts. This first report focuses on the current ‘State of the Sector’, while the second report, to be published in October 2022, will provide an ‘Outlook to 2030’. We hope that this will improve readability and make it easier and more rewarding for readers to engage with the content.

The past few years have been extremely challenging. However, the vision and commitment of many has strengthened the off-grid solar industry and its foundations, shown innovation and entrepreneurship, and the sector has become further recognized for its vital role in achieving a cleaner and more equitable energy transition.



Gabriela Elizondo Azuela
World Bank/ESMAP



Peter Cashion
International Finance Corporation

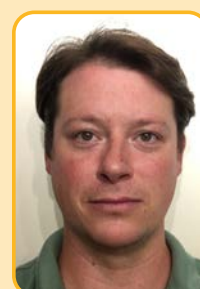

Sam Grant
Efficiency for Access



Koen Peters
GOGLA

Contents

	Foreword.....	3
	Acknowledgments.....	6
	Abbreviations & key definitions	7
	Figures	9
	Tables	11
	Boxes	11
	Headline Trends	12
1	Introduction.....	14
	Scope.....	15
2	The Off-Grid Solar Energy Kit & Efficient Appliance Market	16
	2.1 The Global Electrification Opportunity and Challenges	17
	2.2 Global OGS Market Trends.....	27
	2.2.1 Global Solar Energy Kit Sales Volumes and Market Turnover.....	29
	2.2.2 Global Appliance Sales Volume and Market Turnover	31
	2.3 Insights from the Affiliate OGS Market.....	34
	2.3.1 Solar Energy Kits Affiliate Market Trends	34
	2.3.2 Appliance Affiliate Market Trends.....	40
	2.4 Global OGS Product Pricing Trends	42
	2.4.1 Global Solar Energy Kit Pricing Trends	42
	2.4.2 Global Appliance Pricing Trends	46
3	The Socioeconomic and Environmental Impact of the OGS Industry..	50
	3.1 The Impact of OGS on Energy Access.....	51
	3.2 The Impact of OGS on the Sustainable Development Goals (SDGs)	55
	3.2.1 Powering Healthcare	57
	3.2.2 OGS, Food Security and the Ukraine Crisis.....	58
	3.2.3 OGS and Climate Change: Mitigation, Adaptation and Resilience.....	58
	3.2.4 Clean Energy Jobs, Enterprise and Income Generation.....	61
4	Customer Profiles and Engagement Strategies	62
	4.1 The Off-Grid Solar Customer	63
	4.2 Customer Segmentation and Targeting	65
	4.3 Marketing and Customer Acquisition	67
	4.4 The Role of Programs in Driving Customer Awareness and Impact	72

5	Market Landscape	74
	5.1 Market Classification	75
	5.2. Market Competition	83
	5.2.1 Solar Energy Kits Market Competition	83
	5.2.2 PUE Appliances Market Competition	86
	5.3 Company Performance and Profitability	88
	5.4 Key Trends and Innovations Affecting Competition in the Sector.....	96
6	Technological Innovations	102
	6.1 Developments in the Core OGS Technology	103
	6.2 Digital Innovations and the Rise of PAYGo Technology.....	106
	6.3 Off-grid Appliance and Productive Use Technology and Market Maturity	108
	6.4 Distributed Solar and Storage Technologies with Efficient Appliances to Strengthen the Weak Grid	113
7	Enabling Environment.....	118
	7.1 OGS in the International Agenda	119
	7.2 Status of Integrated Electrification Plans	120
	7.3 Sector Development and Support Programs	124
	7.4 Fiscal Incentives.....	126
	7.5 Industry Regulations.....	127
	7.6 Quality Standards	128
	7.7 Supply Chain, Local Manufacturing and Assembly.....	130
8	Funding Flows	132
	8.1 Investment Flows.....	133
	8.2. Additional Revenue Streams	139
	8.2.1 Subsidies	140
	8.2.2 Climate Mitigation Financing	142
	8.3 Sources of Capital	143
	8.3.1 Capital Provider Trends	143
	8.3.2 Investor Confidence.....	145
	8.4 Regional Trends	146
9	Annexes.....	148
	Annex 1 - Definitions of Key Household Product Segments.....	149
	Annex 2 - Definitions of Key Household and Productive Use Appliance Segments	150
	Annex 3 - Company Typology.....	152
	Annex 4 - Affordability Methodology	153
	Annex 5 - Methodology for Estimating Global OGS Market Value and Sales Volumes	154
	Annex 6 - Affiliate vs. Non-affiliate Live Products Distribution per Country	156
	Annex 7 - Methodology for Estimating the PUE Demand Potential of Sub-Saharan Africa	157
	Annex 8 - Methodology for Estimating the PUE Demand Potential Of India	158

Acknowledgments

The authors would like to thank those who generously contributed their time in the consultations that have informed this report.

ESMAP/World Bank: Gabriela Elizondo Azuela, Sameer Shukla, Dana Rysankova, Johanna Galan, Subrata Barman, Maria Arango, Thomas Flochel, Bonsuk Koo, Lucie Blyth, Jennifer Lynch, Raihan Elahi

International Finance Corporation: Bill Gallery

Efficiency for Access Coalition: Makena Ireri, Leo Blyth, Jenny Corry, Elisa Lai

GOGLA: Susie Wheeldon, Sjef Ketelaars, Drew Corbyn, Laura Fortes, Oliver Reynolds, Collin Gumbu, Patrick Tonui, Rebecca Rhodes, Timona Chore, Koen Peters, Aletta D’cruz, Eva Roig

Open Capital Advisors: Andreas Zeller, Duda Slawek, Harry Masters, Travis Kotecco, Hanna Dohrenbusch, Stephanie Onchwati, Charlene Njau, Linda Karimi

Other contributors: Ed Day (Greencroft Economics), Sanjoy Sanyal (Regain Paradise)



Lighting Global is the World Bank Group’s initiative to rapidly increase access to off-grid solar energy for the 733 million people living without electricity world-wide. Managed by the Energy Sector Management Assistance Program (ESMAP), we work with governments, the private sector, development partners, and end-users, continually innovating to unlock key market barriers and enable access and affordability to those that would otherwise be left behind. Our support has expanded to technologies that go far beyond lighting, including systems to power the needs of households, businesses, schools, and health centers. We operate with funding gratefully acknowledged from ESMAP and their donors. For more information, please visit www.lightingglobal.org



IFC—a member of the World Bank Group—is the largest global development institution focused on the private sector in emerging markets. We work in more than 100 countries, using our capital, expertise, and influence to create markets and opportunities in developing countries. In fiscal year 2021, IFC committed a record \$31.5 billion to private companies and financial institutions in developing countries, leveraging the power of the private sector to end extreme poverty and boost shared prosperity as economies grapple with the impacts of the COVID-19 pandemic. For more information, visit www.ifc.org



Efficiency for Access is a global coalition promoting energy efficiency as a potent catalyst in clean energy access efforts. Since its founding in 2015, Efficiency for Access has grown from a year-long call to action and collaborative effort by Global LEAP and Sustainable Energy for All to a coalition of 20 donor organizations. Coalition programmes aim to scale up markets and reduce prices for super-efficient, off- and weak-grid appropriate products, support technological innovation, and improve sector coordination. Current Efficiency for Access Coalition members lead 12 programmes and initiatives spanning three continents, 62 countries, and 34 key technologies. For more information, please see www.encyforaccess.org



GOGLA is the global association for the off-grid solar energy industry. We are proud to champion one of the world’s most innovative and impactful sectors. Hundreds of millions of people already benefit from affordable, high-quality, clean off-grid solar products and services. With the right support, our pioneering industry will be able to scale up rapidly to improve the lives of 1 billion people by 2030. To help make this happen, we promote, safeguard, and convene the industry, advocating for enabling policies and increased investment as well as supporting our 200+ members with effective services. To find out more, visit www.gogla.org



Open Capital Advisors is a management consulting and financial advisory firm that drives growth, enables investment, and builds markets across Africa. We help businesses, investors, development partners, and the public sector to identify opportunities and deliver unique, impactful solutions. Our mission is to advance African economies and build future generations of business leaders. Since 2010, we have completed over 1000 engagements across 25 countries in sub-Saharan Africa and raised over \$1 billion in capital for impactful businesses across the continent. Our locally based team of over 150 full-time staff brings experience from the world’s top consultancies, private equity firms, investment banks, and development organizations. For more information, please visit www.opencapital.com

Abbreviations & key definitions

Abbreviations

AC	Alternate current	OEM	Original equipment manufacturer
ATL	Above the line	OGS	Off-grid solar
B2B	Business-to-business	PAYGo	Pay-as-you-go
B2C	Business-to-consumer	PnP	Plug and play
BoP	Bottom of the pyramid	PUE	Productive use of energy
BTL	Below the line	PV	Photovoltaic
CAGR	Compound annual growth rate	QV	Quality-verified
CO2e	Carbon dioxide equivalent	RBF	Results-based financing
DC	Direct current	RU	Refrigeration unit
EUS	End-user subsidy	R&D	Research and development
FCV	Fragility, conflict, and violence	SDG7	Sustainable Development Goal 7
IEP	Integrated electrification plan	SEA	Southeast Asia
IoT	Internet of things	SEK	Solar energy kit
LVSP&A	Low voltage smart power & appliances	SHS	Solar home system
LMD	Last mile distributor	SSA	Sub-Saharan Africa
MFI	Microfinance institution	SWP	Solar water pump
MLS	Multi-light system	\$	United States Dollars
MSME	Micro, small and medium enterprises	VAT	Value added tax
MTF	Multi-tier framework	W	Watt
MTR	Market trends report	Wp	Watt-peak

Key definitions

Terms	Definitions
Off-grid solar products	Off-grid solar products include both solar energy kits and off-grid solar appliances and this term is used in the report to describe the breadth of technologies that it covers. See definitions below.
Solar energy kits (SEKs)	<p>These include solar lanterns, multi-light kits and solar home systems (SHS).</p> <ul style="list-style-type: none"> • Solar lanterns are typically packaged as a simple, one-light lantern with one LED light, an embedded 0.5–3.0 Watt-peak (Wp) solar panel, and an internal rechargeable lithium-ion (Li-ion) battery. Some models include USB charging for mobile phones. • Multi-light systems include up to three or four LED lights with a standalone solar panel rated up to 10 Wp and a rechargeable Li-ion battery with most models including USB charging for mobile phones. • Solar home systems (SHS) have a solar panel rated from 11 Wp to usually up to 350 Wp and provide multiple electricity functions, such as lighting and powering a wide range of appliances such as TVs and fans. SHS are offered plug-and-play (PnP) or based on open-market components. In this report, SHS refers to both plug-and-play and component-based systems unless specified.

Terms	Definitions
Off-grid solar appliances	<p>These include solar-powered appliances which are energy-efficient and powered by direct current (DC), and include both household/small business appliances and productive use of energy (PUE) appliances</p> <ul style="list-style-type: none"> • Household and small business appliances are typically used within a home and include televisions, fans, refrigerators and radios. In some cases these products are used in small businesses, such as refrigerators in a shop. Note: a significant majority of solar-powered TVs and a proportion of fans are typically sold bundled with SHS especially in sub-Saharan Africa. • Productive use of energy (PUE) appliances are appliances that leverage solar energy to enable improved or new income generating activities, often in agriculture. These products include solar water pumps, refrigerators/cold rooms or agro-processing equipment.
Access to electricity: The Multi-Tier Framework (MTF)	<p>The MTF, developed by ESMAP, represents an effort to build global, aggregable metrics and a database for evaluating electricity access in a non-binary fashion, measuring the quality of access rather than merely access to any source of electricity. Developed in the context of the Sustainable Energy for All (SEforALL) initiative, the MTF is being used as a more nuanced measure of progress towards Sustainable Development Goal 7 (SDG7), complementary to the binary methodology captured in the Tracking SDG7 report written by major development stakeholders.</p> <p>The MTF redefines energy access to a multi-dimensional definition as ‘the ability to avail energy that is adequate, available when needed, reliable, of good quality, convenient, affordable, legal, healthy and safe for all required energy services.’ That is, having an electricity connection does not necessarily imply having access to electricity under the new definition, which considers additional aspects, such as reliability and affordability. Energy access is measured on a tiered spectrum, from Tier 0 (no access) to Tier 5 (the highest level of access).</p>
Rural	Encompasses all population, housing, and territory not included within an urban area.
Urban	Encompasses all population, housing, and territory included within an urban area.
Unconnected households	Households that are not connected to national grids.
‘Under the grid’ households	Households that are near to but not connected to national grids. Even where a grid connection is nearby and a connection would be technically realistic, households may choose not to connect because of affordability constraints (either high connection costs to the grid or high tariffs to consume from the grid, or both) and poor reliability of service.
Households with unreliable/weak grid	These households face frequent or lengthy outages of grid electricity or experience voltage fluctuations that can damage electrical appliances.
Households connected to reliable grid	These households rarely or never face outages of grid electricity and do not experience voltage fluctuations that could damage electrical appliances.
Potential market	The overall market of people (households and microenterprises) that either lack access to an electricity connection (off-grid) or have a poor-quality electricity connection (unreliable-grid), forming the total potential customer base for OGS devices. This estimate includes customers that currently use OGS devices, as they represent a continued market for additional sales, replacements, and upgrades.
Addressable market	The share of the potential market that can be addressed by current OGS business models. This report analyzes the affordability of devices against the potential market to arrive at an estimate for the addressable market.
Pay-as-you-go (PAYGo)	PAYGo business models allow users to pay for their products via technology-enabled, embedded consumer financing. A PAYGo company will typically offer a solar product (typically solar home systems and multi-light kits) for which a customer makes a down payment, followed by regular payments for a term ranging from six months to eight years. Payments are usually made via mobile money, though alternative methods include scratch cards, mobile airtime, and cash.

Terms	Definitions
Quality-Verified	‘Quality-Verified’ products meet VeraSol Quality Standards, which implement minimum requirements for off-grid lighting product quality, durability, truth-in-advertising, warranty, and lumen maintenance. VeraSol offers Quality Standards for both solar lanterns and multi-light systems and SHS up to 350 W, and compliance is required to participate in VeraSol support programs. Quality Standards are one component of the VeraSol Quality Assurance Program. The International Electrotechnical Commission (IEC) has adopted the VeraSol testing methods as Technical Specification 62257-9-5. For more information, please visit VeraSol.org
Affiliate	<p>Affiliate companies are connected to any of the partner organizations involved in the semi-annual GOGLA sales data reporting process. This matrix of companies includes GOGLA members, companies selling products that meet VeraSol quality standards, and appliance companies that participated in the Global LEAP Awards or are engaging with the Low Energy Inclusive Appliances (LEIA) program.</p> <p>It is important to note that not all products produced by affiliate companies meet VeraSol quality standards, but stakeholders assume that all products affiliate companies produce are of reasonably decent quality.</p>
Non-affiliate	Companies that are not within the matrix of affiliate companies are considered non-affiliate companies. Products distributed by non-affiliate companies are considered non-affiliate products. These companies do not report their sales to GOGLA, and much less is known about the quality and level of Tier access their products provide.

Figures

Figure 1: Tracking the electricity access gap over time	p. 18
Figure 2: Electricity access deficit by country	p. 19
Figure 3: Percentage point improvement in electricity access by country between 2015 and 2020.....	p. 19
Figure 4: Estimated role of off-grid solar in least cost electrification.....	p. 20
Figure 5: Affordability of off-grid solar technologies - ‘conservative’ for the bottom of the pyramid	p. 21
Figure 6: Affordability of off-grid solar technologies - based on nationwide ability to pay profiles.....	p. 22
Figure 7: Change in proportion of households with electricity most/all of the time (2016-21)	p. 23
Figure 8: Potential market for OGS technologies as primary source of electricity or alongside a weak grid	p. 24
Figure 9: Of households using an OGS system, share using it as a secondary source of electricity alongside e.g. a grid connection	p. 25
Figure 10: Estimated total potential and addressable market for cold storage in millions of SHFs in SSA.....	p. 26
Figure 11: Estimated total potential and addressable market for cold storage in millions of SHFs in India.....	p. 26
Figure 12: Estimated total potential and addressable market for solar water pumps in millions of SHFs in SSA.....	p. 27
Figure 13: Estimated total potential and addressable market for solar water pumps in millions of SHFs in India.....	p. 27
Figure 14: Estimated off-grid solar energy kit and appliance market turnover, annual (2021)	p. 28
Figure 15: Affiliate versus non-affiliate share of global sales volume & market turnover	p. 29
Figure 16: Affiliate versus non-affiliate market share in Nigeria, Malawi, and Papua New Guinea.....	p. 29
Figure 17: Global annual sales estimates of solar energy kits, including affiliate and non-affiliate sales (2010-2021)	p. 30
Figure 18: Estimated solar energy kit annual market turnover (2018-2021)	p. 31
Figure 19: Estimated appliance annual sales volumes (2018-2021)	p. 32
Figure 20: Estimated appliance annual market turnover (2018-2021).....	p. 32
Figure 21: Comparison of annual estimates of appliance market turnover (2018-2021).....	p. 33
Figure 22: Global affiliate sales volumes of OGS products by category (2017-2021) (in thousands).....	p. 34
Figure 23: Share of PAYGo solar energy kits sales volumes as percent of total solar energy kit sales volumes 2018-2021	p. 35
Figure 24: Evolution of regional market shares of total affiliate sales of solar energy kits (columns) and total units sold by affiliates in India, Kenya, Nigeria and Cameroon (lines) (2018-2021)	p. 36
Figure 25: Affiliates sales volumes of solar energy kits in South Asia (2018-2021).....	p. 37

Figure 26: Affiliates sales volumes of solar energy kits in East Africa (2018-2021)	p. 38
Figure 27: Affiliates sales volumes of solar energy kits in West Africa (2018-2021)	p. 39
Figure 28: Affiliates sales volumes of solar energy kits in Central Africa (2018-2021)	p. 39
Figure 29: Affiliates sales volumes of TVs in East and West Africa (2019-2021) (thousands).....	p. 40
Figure 30: Affiliates sales volumes of Fans in South Asia and West Africa (2019-2021) (thousands)	p. 41
Figure 31: Global affiliates sales volumes of refrigeration units (2019-2021)	p. 42
Figure 32: Global affiliates sales volumes of solar water pumps (2019-2021)	p. 42
Figure 33: Global indicative cash price ranges of solar lanterns and multi-light system products by wattage (2020 versus 2022)	p. 43
Figure 34: Global indicative cash price ranges of SHS by wattage (2020 versus 2022).....	p. 44
Figure 35: Regional indicative cash price ranges of solar lanterns and multi-light system products	p. 45
Figure 36: Estimated PAYGo down payment of the total contract amount and average PAYGo price as a percentage of cash price for solar energy kit products.....	p. 46
Figure 37: Global indicative cash price ranges for solar TVs and fans.....	p. 47
Figure 38: Estimated PAYGo down payment of the total contract amount for solar water pumps (left) and average PAYGo price as a percentage of cash price (right)	p. 47
Figure 39: Estimated global cash price ranges of PUE appliances	p. 48
Figure 40: People benefiting from access to electricity through solar energy kits (millions)	p. 51
Figure 41: Location of customers using solar kit as a primary source of light/power in 8 countries with high electricity access deficits	p. 52
Figure 42: Additional people with improved electricity access from off-grid solar kits, per year, alongside those who would have gained access had the sector remained on its pre-COVID growth trajectory	p. 54
Figure 43: Examples of how OGS contributes to the SDGs	p. 55
Figure 44: Key impacts of OGS on climate adaptation and resilience.....	p. 59
Figure 45: SHS customers' top five most wanted appliances and features, per region	p. 65
Figure 46: Common OGS marketing channels amongst affiliate B2C companies.....	p. 68
Figure 47: The rural OGS customer	p. 68
Figure 48: The tech savvy urbanite	p. 69
Figure 49: The smallholder farmer.....	p. 71
Figure 50: Electricity access deficit and OGS sales by market type.....	p. 76
Figure 51: Market classification.....	p. 77
Figure 52: Key affiliate market competition statistics.....	p. 85
Figure 53: Number and market value of cash sales and paygo sales from affiliates.....	p. 88
Figure 54: A histogram of the median portfolio quality results of PAYGo companies in 2021	p. 90
Figure 55: Trends in non-weighted mean PAYGo Collection Rate and Write-Off Ratio + RAR 30	p. 91
Figure 56: Consumer experience and satisfaction ratings for 15 PAYGo SHS companies	p. 92
Figure 57: The number and type of quality-verified products listed by VeraSol	p. 104
Figure 58: The Connect Initiative Universal Family of Connectors for 12V SHS Kits, lights, and appliances	p. 105
Figure 59: Use case and product segmentation of off-grid solar cooling technology.....	p. 110
Figure 60: World Bank funding for off-grid solar between July 2015 and June 2022.....	p. 124
Figure 61: Investment sources and revenue streams in the off-grid solar sector.....	p. 133
Figure 62: Investment amount by investment type	p. 134
Figure 63: The 7 scale-ups - historical investments (equity, debt and grant)	p. 135
Figure 64: Investment trends in seed start-up and growth companies (equity, debt and grant)	p. 137
Figure 65: Number of companies receiving equity per year (per ticket size).....	p. 137
Figure 66: Investor survey 2020 & 2021: How is your off-grid solar portfolio performing relative to your financial expectations?	p. 145
Figure 67: Investor survey 2021: Relative to past years, how do you expect your off-grid solar activity to change in 2022 (in terms of total amount invested)?	p. 146
Figure 68: Investment amount by geographical focus of funds	p. 147

Figure 69: Companies selling solar energy kits and services.....	p. 152
Figure 70: Companies selling off-grid solar appliances	p. 152
Figure 71: Estimated non-affiliate market share per MTF country (2021).....	p. 156

Tables

Table 1: Correlation between SHS sales and appliances / PUE sales.....	p. 83
Table 2: Slower-growth and locally-owned LMDs have realized higher revenues per \$ of capital raised than faster-growth and foreign-owned LMDs. Data from 15 LMDs selling off-grid solar products.....	p. 93
Table 3: Technology and Market Maturity Map of solar appliance technologies for off-grid use cases	p. 109
Table 4: Results Based Financing funds.....	p. 141
Table 5: Indicative prices of off-grid solar products (\$).....	p. 153

Boxes

Box 1: ‘Affiliate’ and ‘non-affiliate’ products.....	p. 28
Box 2: The solar direct drive (SDD) refrigerator: A game-changer for vaccine storage.....	p. 57
Box 3: Easy Solar: A marketing journey	p. 66
Box 4: FuturePump: ‘Training the Trainers’ - making more, and appropriate, sales	p. 72
Box 5: Lighting Global ‘Non-Stop Life’ India campaign: A hybrid approach	p. 73
Box 6: Challenges and lessons learned in increasing electrification in Chad and Mozambique.....	p. 78
Box 7: OGS electrification projects and PAYGo development boosting electricity access in Nigeria	p. 80
Box 8: Support is still needed to incentivize OGS companies to reach unserved population targeted for OGS electrification in Rwanda	p. 81
Box 9: Unreliable grid solutions and PUE appliances present new opportunities for OGS companies in India	p. 82
Box 10: PAYGo market data, a new era of transparency and insights.....	p. 89
Box 11: Two sides, one coin: credit risk management and consumer protection	p. 91
Box 12: Pawame’s struggles through COVID	p. 95
Box 13: Enhancing cold storage models to increase value to end-users and drive PUE demand	p. 98
Box 14: Rent-To-Rent; an innovative business model for BoP customers.....	p. 100
Box 15: The Connect Initiative.....	p. 105
Box 16: Second-life lithium batteries	p. 106
Box 17: Aeris IoT solution provider	p. 107
Box 18: SureChill’s phase change material and smart controller technology	p. 111
Box 19: Solar generators gather pace in Nigeria.....	p. 115
Box 20: SparkMeter	p. 116
Box 21: Challenges faced and lessons learned from implementation of Kenya’s NEP	p. 122
Box 22: The Community of Champions: A growing and evolving network.....	p. 123
Box 23: VeraSol Quality Assurance program.....	p. 128
Box 24: The Benin Zawoue project: Solar energy kits made in Benin by LAGAZEL	p. 131
Box 25: GOGLA Investments Database.....	p. 134
Box 26: Sun King raises \$260 million in equity in 2022	p. 136
Box 27: Locally-owned and managed companies.....	p. 138
Box 28: Relief funding in the off-grid solar industry during COVID-19.....	p. 138
Box 29: Productive use of energy (PUE) focused companies capital raises in 2020 and 2021	p. 139
Box 30: Climate-aligned financing in off-grid solar	p. 142
Box 31: \$500 million Gigaton Empowerment Fund by SunFunder.....	p. 143

Headline Trends



The sector has proven more resilient than many people expected when the COVID-19 pandemic erupted

While many companies have struggled in the face of the COVID-19 pandemic, the sector has shown resilience. After a 22% decline in solar energy kit sales in 2020, the OGS sector recorded a 10% increase in sales in 2021, indicating a nascent recovery from the impacts of the pandemic. The annual market for appliances is yet to recover from a sustained 19% decline since 2019.



Solar energy kits remain the most cost-effective solution to electrify hundreds of millions of off-grid homes and businesses, but ability to pay is a continuing challenge

In 2020, 733 million people were still living without access to electricity, of which 298 million people are in nascent OGS markets where there is little commercial OGS activity.

Off-grid solar technologies are the key technology in most regions to advance progress towards SDG7 in the near term. On a trajectory to achieve universal access to electricity by 2030, high-level analysis indicates off-grid solar technologies are expected to be the least-cost solution for 41% of new household connections between 2020 and 2030.

However, the affordability challenge was further exacerbated by declining income levels due to the pandemic. Assuming consumer finance is readily available, between 177 to 277 currently unconnected people are still unable to afford a Tier 1 solar energy kit. In the absence of consumer financing options, such as PAYGo, affordability levels drop even further.



Despite the pressure the pandemic has placed on supply chains and income levels, the number of people gaining electricity access from solar energy kits has continued to grow and has now reached 490 million

The number of people accessing solar energy kits has grown from 420 million people in 2019 to over 490 million people by the end of 2021, with more people gaining higher 'Tier 2' levels of access.

This is a result of continued sales, the longer lifespan of larger products and current customers beginning to move up the 'clean energy staircase'. This is where they have paid off, or made savings from their initial solar energy kit and are able to purchase a new, often larger product and additional service(s).

3.8 million customers have also gained access to solar TVs in 2020 and 2021, which were particularly critical for accessing news, health information and educational programs during COVID-19 lockdowns.



Investments have continued to grow since 2012, reaching over \$2.3 billion cumulatively. The sector is bifurcated into two streams: 7 companies operating at scale that absorb the vast majority of investments, and a large number of companies that are still in their seed and start-up phase

Between 2012 and 2021, the off-grid solar sector has raised \$2.3 billion in capital through debt, equity and grants. From 2016 to 2020, the industry saw yearly investment volumes plateauing between \$300 million and \$350 million, before reaching \$457 million in 2021. This year (2022) is set to be another record breaking year.

The largest share of funding has been assigned to East Africa (49%), as larger, scale-up companies are attracting debt in their most established markets. Companies that are in their seed or start-up phases have attracted significantly less capital.



Stronger focus by governments and development partners on productive use of energy and powering healthcare

Governments, investors and development partners are increasingly recognizing the potential of OGS solutions to power productive use of energy (PUE) appliances and healthcare.

In 2021, \$7.7 million of the total \$10.2 million grant capital invested in the industry was absorbed by PUE companies, while the World Bank, IKEA Foundation, EnDev, GIZ, UK Aid and Power Africa all committed funding to support the electrification of healthcare facilities and/or uptake of PUE appliances.



There have been rapid advancements in the maturity of productive use technologies

Solar water pumps (SWPs) and solar cooling, seen as ‘emerging’ technologies two years ago, are now classified as ‘near-to-market’. SWPs on the market today are more efficient, affordable, and impactful - they now typically feature brushless direct current motors, PAYGo capabilities (with firmware and GSM-enabled), and are IoT-enabled for enhanced monitoring, controls, and provision of information to the user.

Solar cooling is considered ‘near-to-market’ following intensive research and development efforts due to the increased demand for vaccine storage and high potential for productive use. Attention has focused on the potential to reduce food loss and waste in various agricultural value chains. Recent innovations in fridge insulation, efficient compressors, and better controllers are driving down costs, and improving efficiency and durability.

Solar irrigation and cooling systems are proving to be a key resource for rural communities. They are contributing to increased crop yields and preserving produce.



OGS products help achieve a faster and just clean energy transition

700 million climate-vulnerable people live without electricity access, yet have also contributed the least to climate change. Off-grid solar solutions provide a fast and affordable way to provide basic electricity access from clean energy sources while rapidly reducing CO₂e and building the adaptive capacity and resilience of climate-vulnerable people.

Replacing kerosene lanterns with solar lighting has already avoided an estimated 190 million tonnes of CO₂e, equivalent to taking 51 coal-fired power plants offline for a year, while replacing diesel generators also has clear emissions reduction benefits. Recent research conservatively estimates that diesel generators used to provide grid back-up emit more than 100 megatons of CO₂ every year. In sub-Saharan Africa alone, replacing these generators with solar alternatives would avoid as much CO₂ as 20% of the region's vehicles being replaced with clean alternatives.

Off-grid solar solutions also build the adaptive capacity and resilience of climate-vulnerable people. Contributors include better water supply, cooling and food security, improvements to health and health infrastructure, greater communications and connectivity, and increased savings and income.



There is growing recognition that more public funding will be needed to reach remote and lower income customers, and to bridge affordability gaps

Over \$211 million of public funding has been disbursed or is currently disbursing to the sector through Results-Based Financing since 2013, and more than \$100 million came on stream in 2020 alone.

Whilst supply-side subsidies have been used as a tool to drive the uptake of OGS for a number of years, a better understanding of the growing affordability gap has also led to increasing interest in and recognition for the need of end-user subsidies.



While rural homes and businesses make up the clear majority of OGS customers, the COVID-19 pandemic has accelerated a trend for companies to additionally service urban and weak grid markets

The majority of solar kit customers are rural, male and living under the poverty line of \$3.10. However, an estimated 775 million people are connected to weak grids, undermining the potential social and economic development of access to electricity.

New technology segments are emerging that integrate distributed solar and storage with weak grid to dramatically improve the quality and affordability of electricity access. The COVID-19 pandemic has accelerated a trend for some companies to service urban and weak grid markets, with these customers often buying larger solar kits and appliances.



‘PAYGo everything’ is here

The PAYGo technology that unlocked consumer financing for solar energy kits can be used with virtually any electronic device and is now being leveraged to offer consumer finance on smartphones, electric motorbikes, and many other devices, as well as offer digital financial services.

Companies are now also commonly ‘cross-selling’ their existing customers' new products and services, using their own PAYGo data on customer payments and energy usage to help them move up the ‘clean energy staircase’ and/or to access ‘beyond energy’ products.



01

Introduction

Introduction

For more than a decade, the biennial **Off-Grid Solar (OGS) Market Trends Report (MTR)** has been the anchor of the **World Bank Lighting Global/GOGLA franchise of reports**. They are the go-to source of OGS sector information for investors, industry members, policymakers, and other stakeholders. The series includes semi-annual reports that track sales and impact results by country, region, and worldwide for VeraSol Quality-Verified and other branded solar devices sold by GOGLA affiliates.¹ Each MTR offers a deep dive into trends in the sector, alongside new research and data, to deepen understanding among market players and illuminate the pathway forward.

The **off-grid solar sector is very diverse**. Today, it includes an increasing number of stakeholders, markets, and products across a multi-faceted, multi-layered industry. Capturing all developments within this fast-moving sector in one report is a challenge. Evolving from previous editions of the MTR, the 2022 report will not attempt to provide an all-encompassing overview. Instead, it distills the main trends and insights and offers an in-depth analysis of developments likely to have the largest impact on the future of the off-grid market and its contribution to electricity access targets.

To further improve readability, the 2022 MTR is, for the first time, in two parts. This first report will focus on the 'State of the Sector', while the second report, to be published in October 2022, will provide an 'Outlook to 2030'. The 'State of the Sector' report provides insights into key trends in the off-grid solar sector over the past two years, including business models, technologies, competitive landscape and funding. The 'Outlook to 2030' will profile the potential of the industry to help meet development goals, and to explore trends and drivers that must be enhanced and addressed to drive electricity access.

Scope

The product scope of the MTR has traditionally been solar energy kits, including household appliances. This time, it includes a substantive focus on productive use of energy (PUE), in partnership with the Efficiency for Access Coalition. Annex 1 and 2 give an overview of the products in this report, including product characteristics.

The market scope remains the same. The MTR covers all countries with an electrification deficit and humanitarian settings in which a sizable number of people are currently energy deprived. Consumers include households, micro enterprises, small enterprises, and smallholder farmers.

Finally, the off-grid solar industry consists of a wide variety of companies, including vertically integrated companies, distributors and service providers. An overview of relevant company typologies can be found in Annex 3.

The remainder of this report is structured as follows:

- **Chapter 2 - The Off-Grid Solar Energy Kit & Efficient Appliance Market**, sets out the global electrification challenge and opportunities and the role of off-grid solar. Additionally, it examines sales and turnover of the off-grid solar sector, product types, and pricing.
- **Chapter 3 - The Socioeconomic and Environmental Impact of the OGS Industry**, provides insight into the socioeconomic and environmental impact of the sector.
- **Chapter 4 - Customer Profiles and Engagement Strategies**, describes the OGS customer and how companies segment and engage with their customers.
- **Chapter 5 - Market Landscape**, provides insight into different market types and market concentration, as well as company performance and profitability.
- **Chapter 6 - Technological Innovations**, assesses the latest trends in technology and digital innovations.
- **Chapter 7 - Enabling Environment**, analyzes the status and implementation of integrated electrification plans, and describes programs that are supporting OGS and policies and sector regulations required to drive progress in electricity access.
- **Chapter 8 - Funding Flows**, describes the investment landscape, looking at sources of capital and recipients of investment, public funding including results-based financing, and broader financing trends.



¹ For more information, please see <https://www.gogla.org/global-off-grid-solar-market-report>. VeraSol is an evolution of the World Bank's Group Lighting Global quality verification and assurance program. For more information, please see <https://verasol.org/>

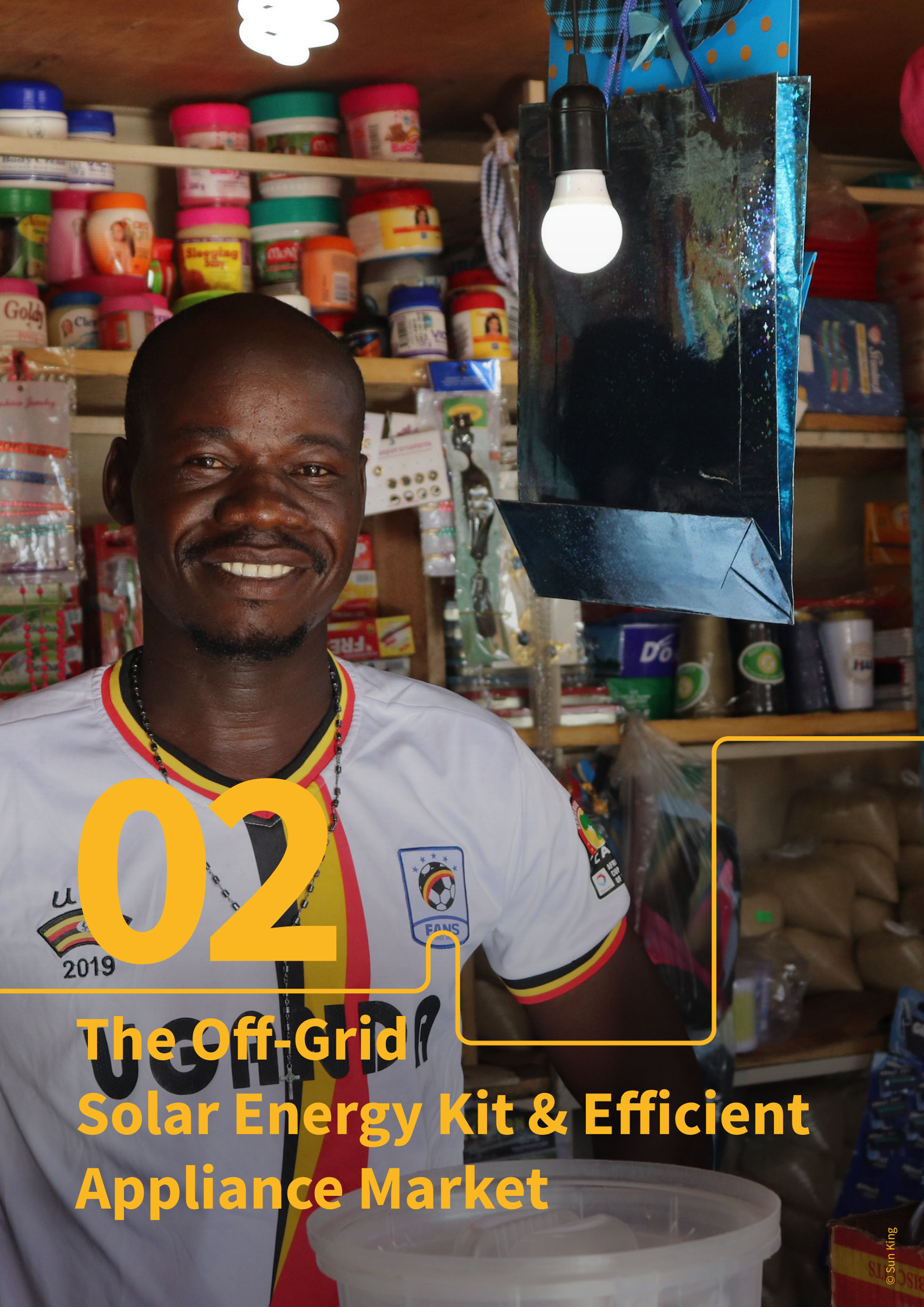

02

**The Off-Grid
Solar Energy Kit & Efficient
Appliance Market**

KEY MESSAGES

Demand

- 733 million people still lack access to clean modern and reliable electricity worldwide and solar energy kits are the best suited solution to electrify an estimated 55% of households in the next five years
- Affordability is the key constraint to closing the electricity access gap
- Many households in emerging markets are connected to weak grids. Off-grid solar can play an important role in improving the quality of electricity access here
- There is also a sizeable additional market opportunity for solar appliances and for productive use of energy technologies particularly in the agriculture sector

Sales

- The total off-grid solar market is currently worth an estimated \$2.8 billion annually (2021)
- In 2020, sales volumes of solar energy kits declined 22% as a result of the COVID-19 pandemic; sales volumes then increased 10% in 2021, signaling the onset of a recovery
- COVID-19 negatively affected the market for standalone household and productive use appliances, with sales not recovering to 2019 levels due to supply chain disruptions and lower customer ability to pay, particularly for larger productive use appliances
- The pandemic has accelerated regional sales trends such as declining sales in South Asia, a slowdown in mature East African markets, and growth in key West and Central African markets

Pricing

- Pandemic-related supply chain disruptions have increased nominal prices for off-grid solar products, though increased competition has led to a wider range of products and price points
- PAYGo financing continues to drive uptake of off-grid solar products by increasing affordability

2.1 The Global Electrification Opportunity and Challenges

In 2020, 733 million people were still living without access to electricity, of which over 80% were in rural areas.^{2,3} While this number has steadily fallen over the past

decade (Figure 1), the current rate of progress would still take at least 17 years to reach everyone with Tier 1⁴, clean and modern electricity.



The electricity access gap remains significant at over 730 million people, and progress towards universal access is lagging.

2 For consistency with the SDG7 tracking reports we report the same electricity access figures here which represent either: [1] where surveys based on the Multi-Tier Framework have been conducted, access to electricity service from Tier 1 to Tier 5 is considered; [2] elsewhere, electricity access is calculated by a binary measure of “connected” or “not connected” derived from existing household surveys, such as the Demographic and Health survey and the Living Standards Measurement study.

3 In each of the last three editions of the SDG7 Tracking estimates the share of the electricity gap in rural areas has been stable at around 84%.

4 The Tiers of energy access are described in the Multi-Tier Framework (MTF), developed by ESMAP. The MTF represents an effort to build global, aggregable metrics and a database for evaluating electricity access. Energy access is measured on a tiered spectrum, from Tier 0 (no access) to Tier 5 (the highest level of access).

Figure 1: Tracking the electricity access gap over time

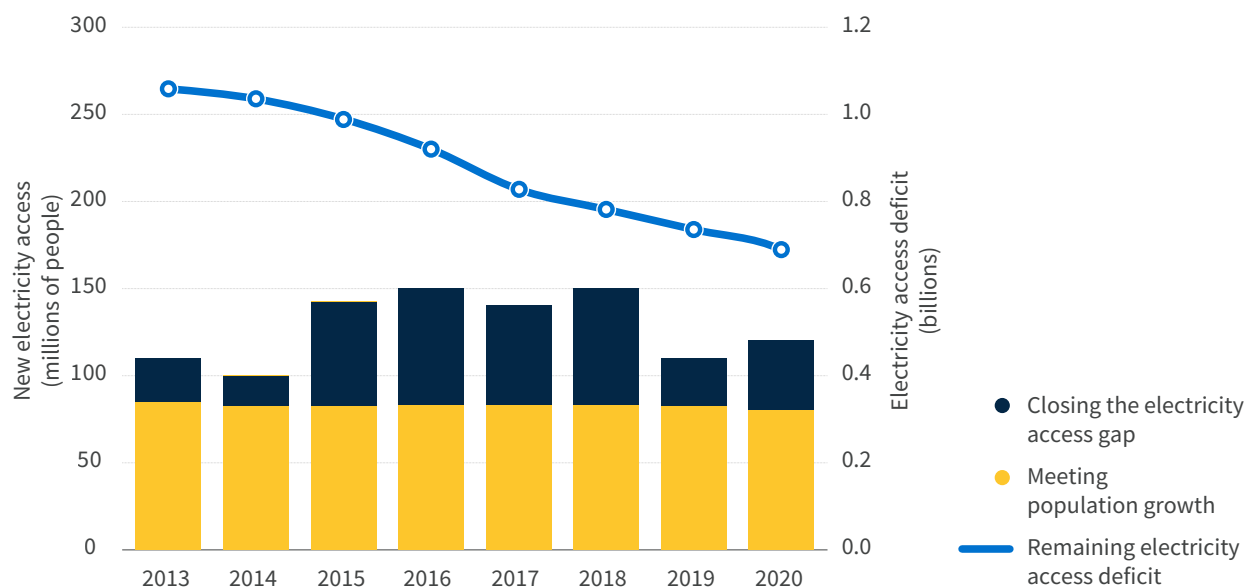

Sub-Saharan Africa accounts for 77% of the current electricity access gap.^{5,6} As shown in Figure 2, most countries in SSA still have an electricity access gap of at least two million people, with Nigeria (90 million), the Democratic Republic of Congo (DRC) (72 million), and Ethiopia (56 million) accounting for 30% of those without electricity access.

Electrification has expanded quickly in some South Asian countries, but many people remain without electricity access. India's rate of electrification rose from 88% in 2015 to 99% in 2020, although over 10 million people still lack access. In Bangladesh, electrification rose from 75% to 96% over the same period, leaving six million people without Tier 1 electricity access.

While some electricity access deficit countries are closing the gap quickly, others show slow progress. For example, while Ethiopia narrowed its electricity access gap from 71% in 2015 to 49% in 2020, around 56 million people remain without access. Progress has been much slower in DRC, with the deficit reducing only slightly from 84% to 81% over the same period, leaving around 72 million people without access. Meanwhile, Pakistan has also made only incremental progress in closing the gap from 29% in 2015 to 25% in 2020, leaving around 54 million people without access (Figure 3).

Around half of unconnected households live in fragile and conflict-affected countries.⁷ As discussed in Section 5.1, the electricity access gap is concentrated in nascent markets where OGS sales are not yet reaching high volumes. This poses additional challenges to deployment of off-grid solar technologies, including raising the operational/logistics costs, security risks that companies and investors may not be able to accept, and making it harder to offer end-user finance to spread the cost of acquiring an OGS system, when creditworthiness and security is not certain. The challenges posed by fragility are worsening as climate and economic pressures, and conflicts are increasing displacement of people. The UNHCR reported over 80 million forcibly displaced persons worldwide in 2020, up from 70 million in 2018.⁸

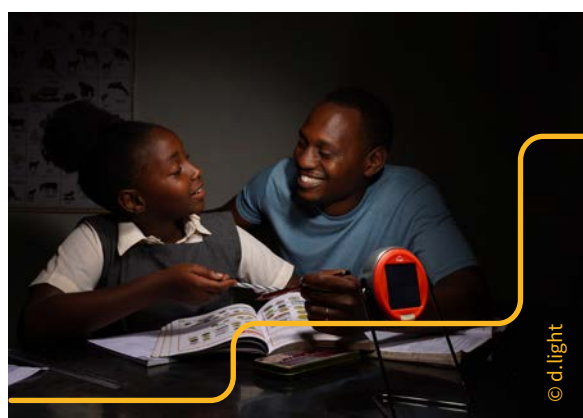

⁵ Open Capital Advisors analysis of SDG7 tracking data.

⁶ Open Capital Advisors analysis of SDG7 tracking data used for electricity access figures and trends throughout this section.

⁷ IEA (2021), *Tracking SDG7: The Energy Progress Report 2021*.

⁸ UNHCR (2021), *Global Trends: Forced Displacement in 2020*.

Figure 2: Electricity access deficit by country⁹

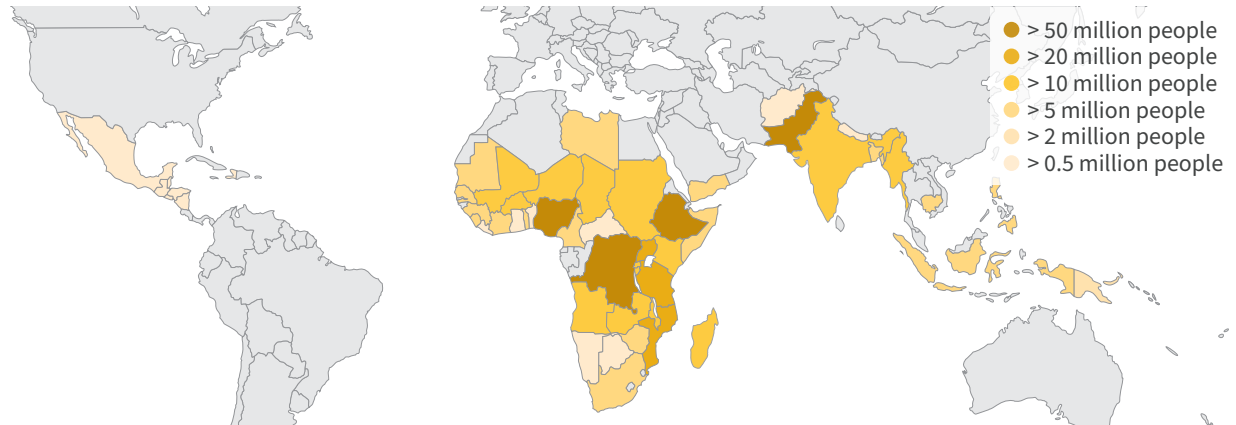
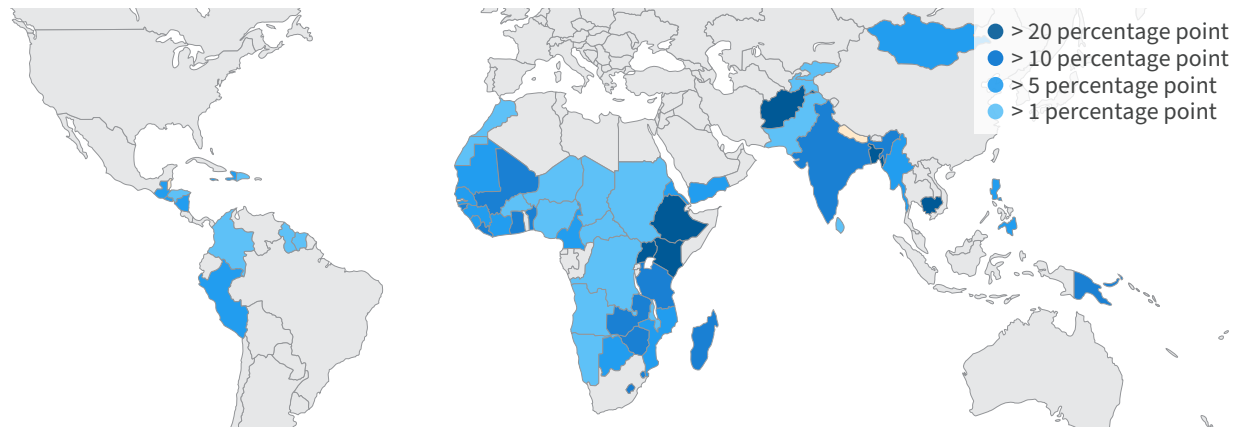

Figure 3: Percentage point improvement in electricity access by country between 2015 and 2020¹⁰



Off-grid solar is estimated to be the most cost-effective, feasible solution to electrify 55% of currently unconnected households in the next five years.

Off-grid solar technologies are expected to be the dominant technology to unlock progress towards SDG7 in most regions in the near term, and will continue to play an important role in the long term. On a trajectory to achieve universal access to electricity by 2030, OGS technologies are estimated to be the most cost effective and feasible solution for 55% of new household connections in the next five years (estimates from 2020 to

2025),¹¹ as shown in the left panel of Figure 4, given that OGS technologies are able to expand faster than the main grid and mini-grids in the short term. By 2030, the share of mini-grid and grid connections is expected to increase, but OGS is still expected to account for 41% of all connections realized, based on geospatial least-cost modeling of universal energy access scenarios. The ultimate share of grid, mini-grid and OGS technologies in the electrification mix of 2030, however, will depend not only on the least-cost pathway but also on the pace at which each technology is able to expand.

As grid infrastructure expands, some of the households initially using SEKs may partly transition to a grid or a mini-grid connection. OGS technologies can still play an important role as a secondary source of electricity. While, in the medium term, OGS is expected to contribute 41% of new connections, there will also be the need and market opportunity for solar energy kits - which include solar lanterns, multi-light systems and solar home systems - to

9 Open Capital Advisors analysis of SDG7 tracking data and UN Population Division data.

10 Open Capital Advisors analysis of SDG7 tracking data.

11 Estimate based on analysis of the Global Electrification Platform, 'Low Demand' scenarios.

be deployed alongside the grid or mini-grids, in particular for new and existing grid connected households that face grid reliability challenges.

In most regions, OGS technologies are expected to drive long-term electrification, and significantly contribute to universal energy access in the medium term. For example, geospatial analysis suggests that in Central Africa OGS is likely to be the least-cost solution for 81% of new connections between 2020-25, as grid infrastructure is currently underdeveloped and is unlikely to be able to scale up quickly enough in the next few years. However, as the grid and mini-grids are expected to expand more

rapidly in the medium term, only 45% of new connections in Central Africa between 2020-30 are expected to come from OGS technologies. In Southeast Asia the trend is reversed, where main grid and mini-grid connections could reach a significant share of populations currently located near a regional grid, but OGS becomes more important over time rising from 6% of new connections between 2020-25 up to 10% of new connections between 2020-30. This is because, over time, increasingly remote and marginalized communities will make up a growing proportion of those left unelectrified.

Figure 4: Estimated role of off-grid solar in least cost electrification¹²

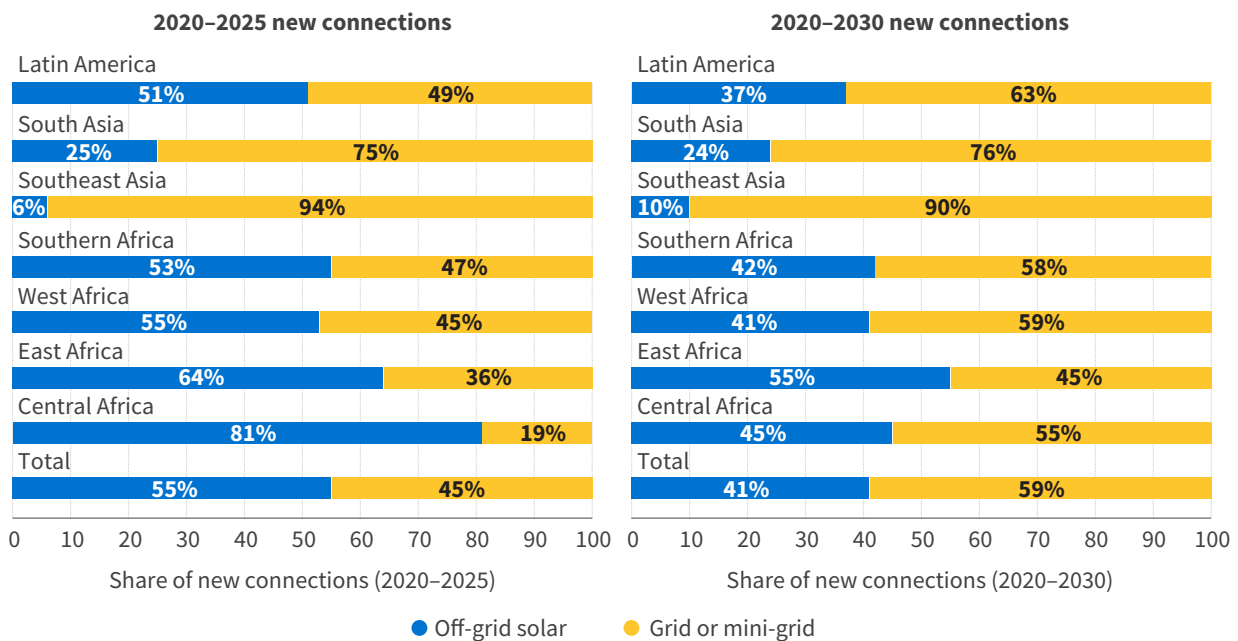

Affordability is the key constraint to closing the electricity access gap.

Ability to pay for solar energy kits remains a challenge. To provide an indication of global demand for off-grid solar solutions, this section describes two types of estimates of ability to pay which represent two extreme ends of affordability (i.e. a minimum and a maximum):¹³

- **Conservative demand curve** - assumes that the unelectrified population is concentrated in the poorest strata of the population, as per the Energy Access Diagnostic Multi-Tier Framework surveys where the electricity access deficit is highly concentrated in the lower income quintiles.
- **Nationwide demand curve** - assumes that the unelectrified population is distributed across all income strata as per the national income distribution in each country. This may also better represent the potential market for households already with some form of electricity access (i.e. upgrading existing SEKs or using SEKs alongside a weak grid connection).

¹² Open Capital Advisors analysis of results from the Global Electrification Platform, 'Low Demand' Scenario.

¹³ A full methodology description is provided in Annex 4.

Ability to pay is compared to global average prices of SEKs, assuming PAYGo or other end-user finance is available for multi-light higher capacity systems. This provides a high-level estimate of what *could* be affordable,

although in practice PAYGo is not widely available for Tier 1 multi-light systems, and conversely, some companies are using PAYGo for smaller products (less than 3 Wp), but this is not yet widespread.

Ability to pay - conservative demand estimates

Figure 5: Affordability of off-grid solar technologies - 'conservative' for the bottom of the pyramid¹⁴

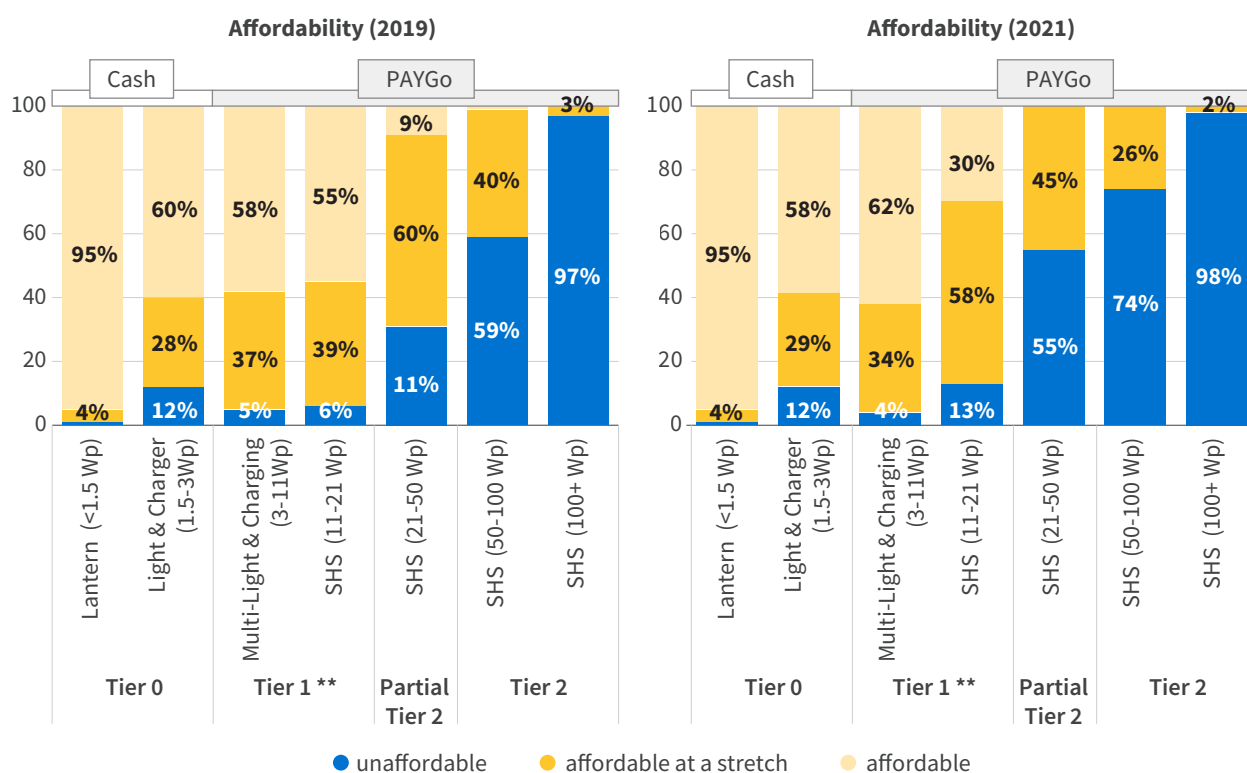

In the last two years, affordability has decreased, in particular for larger capacity SHS. Ability to pay has declined as incomes have fallen. Product prices have also increased, reversing a trend of consistent year-on-year improvements in both ability to pay, and falling off-grid solar prices for the previous decade.

The exception is for Tier 1 multi-light and charging systems, where price reductions have slightly improved affordability. Around 62% of households at the bottom of the pyramid could afford a Tier 1 multi-light and charging system, up from 58% two years ago.

Among these bottom of the pyramid (BoP) customers, the potential market is limited to entry-level SHS and solar lanterns, and multi-light systems products. As shown in the right hand side of Figure 5, a 21-50 Wp SHS costing around \$500 would be out of reach for all households unless they allocate between 5% and 15% of their consumption expenditure to electricity access. This would mean significant trade-offs with other primary goods. Even small solar lanterns and multi-light systems products - typically sold in cash over-the-counter would be unaffordable for 42% of these households, although with PAYGo or other forms of consumer finance affordability improves slightly for Tier 1 multi-light and charging systems.

¹⁴ Consortium analysis of various sources - see Annex 4 for details. Note the methodology for estimating affordability has been modified since the previous MTR, so estimates for both 2019 and 2021 are (re)calculated in this report.

Note: ** for the purposes of this analysis, multi-light systems are categorized as Tier 1, and the price used for this analysis is representative of a multi-light system that would reach full Tier 1 for a household. Overall, over 83% of GOGLA affiliate multi-light systems sold between 2019 and 2021 qualify as full Tier 1, although it should be noted that 17% would fall just short of full Tier 1.

Ability to pay - national income distributions

Figure 6: Affordability of off-grid solar technologies - based on nationwide ability to pay profiles¹⁵

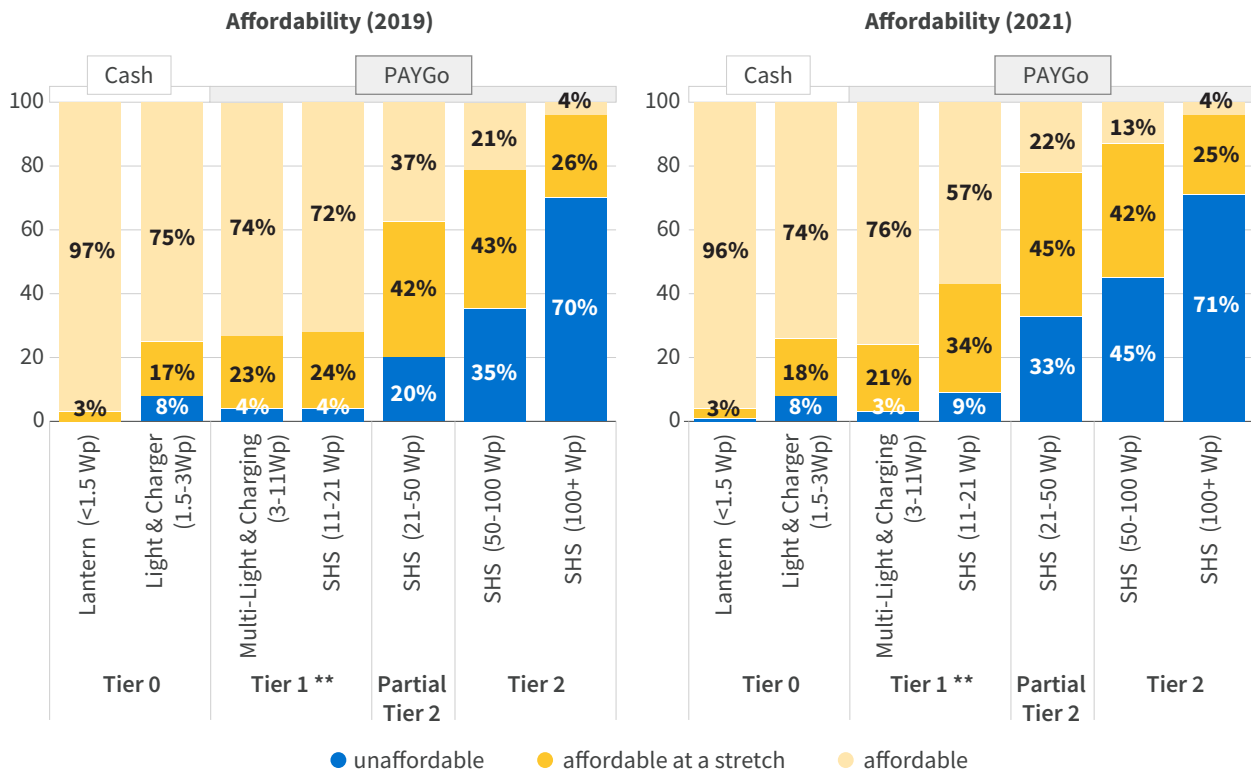

Across national income distributions, around 76% of households could afford a Tier 1 multi-light and charging system and larger systems are commercially viable for some households (Figure 6). For this demand curve, there are some affluent households - likely predominantly in urban and peri-urban areas - which may be able to afford medium capacity, and in some cases high-capacity, solar home systems. Unlocking demand from these households will be a key to commercial success for companies, while also reaching more vulnerable BOP households.

Affordability - practical discussion

Between 566 million and 730 million unserved people would be unable to afford the full cash price of a Tier 1 solar energy kit. If the income distribution of remaining unconnected households most closely resembles the bottom of the pyramid demand curves above, of 733 million unconnected people only between 3 million and 167 million could afford to buy a Tier 1 multi-light and charging system upfront. Even if unconnected households

have a similar income distribution to the national context of their country, 566 million people would still be unable to afford a Tier 1 system in a single upfront cash payment.

PAYGo is essential to address affordability, but not sufficient to close the affordability gap. With end-user finance available, those currently unconnected and unable to afford a Tier 1 system could fall to between 177 million and 277 million people.

Affordability may be more limited than previously thought, as the ability to pay among the poorest communities may be lower than estimated and could worsen. As a result of the COVID-19 pandemic, per capita income has declined in many countries; for 40% of emerging market and developing economies it is not expected to return to pre-pandemic levels for several years.¹⁶

The pandemic has also resulted in job losses and deprivation in already vulnerable communities (largely rural and agricultural); overall it is estimated that

¹⁵ Consortium analysis of various sources - see Annex 4 for details.

Note: ** for the purposes of this analysis, multi-light systems are categorized as Tier 1, and the price used for this analysis is representative of a multi-light system that would reach full Tier 1 for a household. Overall, over 83% of GOGLA affiliate multi-light systems sold between 2019 and 2021 qualify as full Tier 1, although it should be noted that 17% would fall just short of full Tier 1.

¹⁶ World Bank Group (2022), *World Economic Prospects*.



COVID-19 pushed 100 million people into extreme poverty in 2020 alone.¹⁷ The global fuel and food security crisis caused by the war between Russia and Ukraine, as well as rapidly rising inflation, will lead to continued financial pressure on low income households. The World Bank expects this will push millions more people into poverty and tip countries into a debt crisis,¹⁸ especially as countries have already stretched central resources and fiscal mechanisms to respond to the pandemic.

Furthermore, the cost to reach the remaining unconnected households is also likely to be higher than the global average prices. The affordability analysis is based on globally representative price points, which reflect predominantly commercial sales to customers that can now pay for these products and may not reflect the true cost to serve currently unconnected households, which may be in relatively remote and difficult (i.e. costly)-to-reach locations. The impact of COVID-19 has added

Many households in emerging markets are connected to weak grids, alongside which off-grid solar can play an important role in improving the quality of electricity access.

pressure to supply chains, driving price increases in OGS products since 2020 (discussed further in Section 2.4), making it even more difficult to serve unconnected households in lower income groups or remote locations.

Grid reliability remains a major challenge in sub-Saharan Africa. The proportion of people reporting an unreliable grid connection has remained largely unchanged across 32 African countries included in the Afrobarometer surveys between 2016 and 2018 (Figure 7),¹⁹ while electricity utilities in emerging countries still struggle to be financially sustainable with the gap between costs and revenues widening between 2012 and 2018.²⁰

Figure 7: Change in proportion of households with electricity most/all of the time (2016-21)²¹

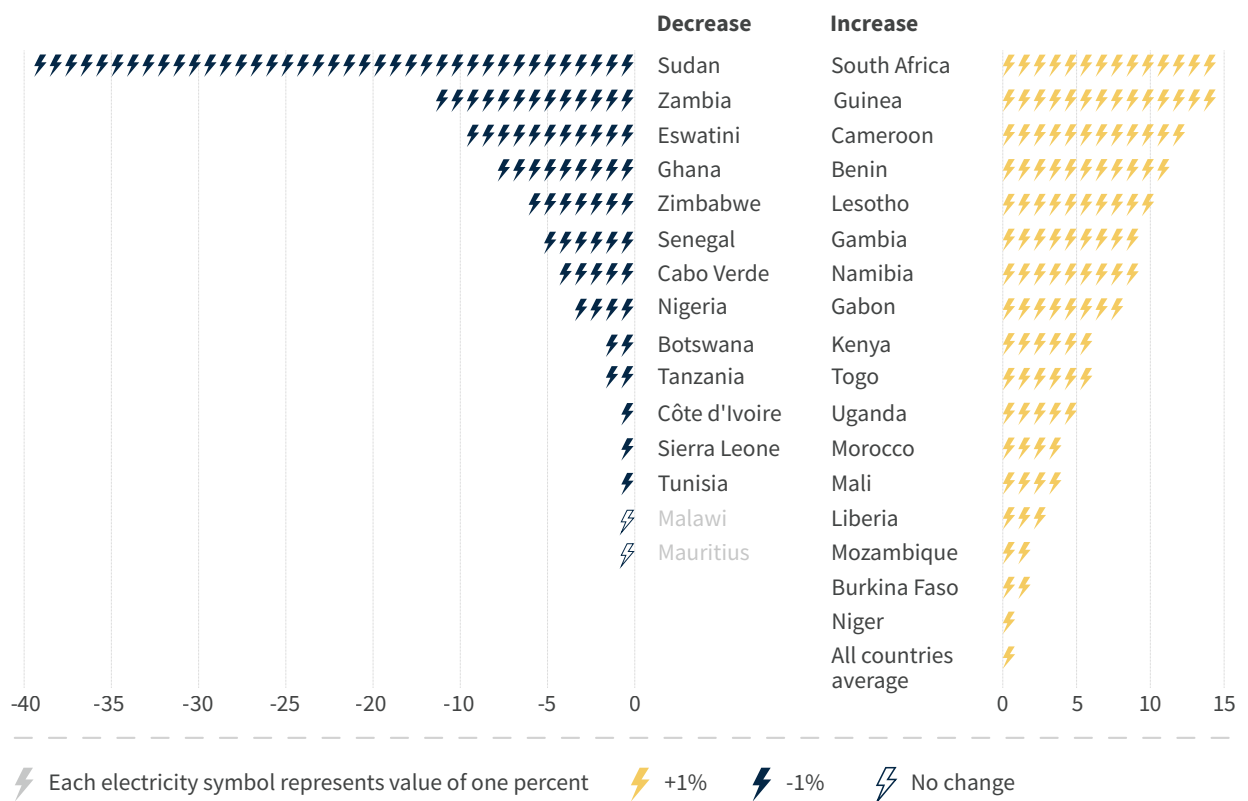

17 [World Bank Group \(2020\), Poverty and Shared Prosperity 2020: Reversals of Fortune.](#)
 18 [Financial Times \(2022\), Ukraine War will Increase Poverty in Developing Economies, Warns World Bank.](#)
 19 [Afrobarometer \(2022\), Still Lacking Reliable Electricity from the Grid, Many Africans Turn to Other Sources.](#)
 20 [Balabanyan et al. \(2021\), Utility Performance and Behavior in Africa Today.](#)
 21 [Open Capital Advisors Analysis of Afrobarometer data.](#)

In India the grid now reaches almost 100% of households and reliability appears to be improving. New Delhi Council on Energy Environment and Water (CEEW) researchers found that electricity supply availability from the grid has increased from an average of 12.5 hours in 2015 to 18.5 hours in 2020, while satisfaction levels among rural customers increased from 23% to 73%.²² Yet half of rural customers face daily power cuts in peak winter evening hours, and this is likely more pronounced during the period of peak residential power in the hot summer months.

The potential market for customers with a weak grid connection is around 775 million people. The largest potential market for OGS as backup is in South Asia (447 million people), although this market is shrinking with improvements to the quality of grid access in India. The next largest potential markets for OGS as backup solutions are Southeast Asia and Pacific region (130 million) and West Africa (94 million) (Figure 8).

Figure 8: Potential market for OGS technologies as primary source of electricity or alongside a weak grid²³

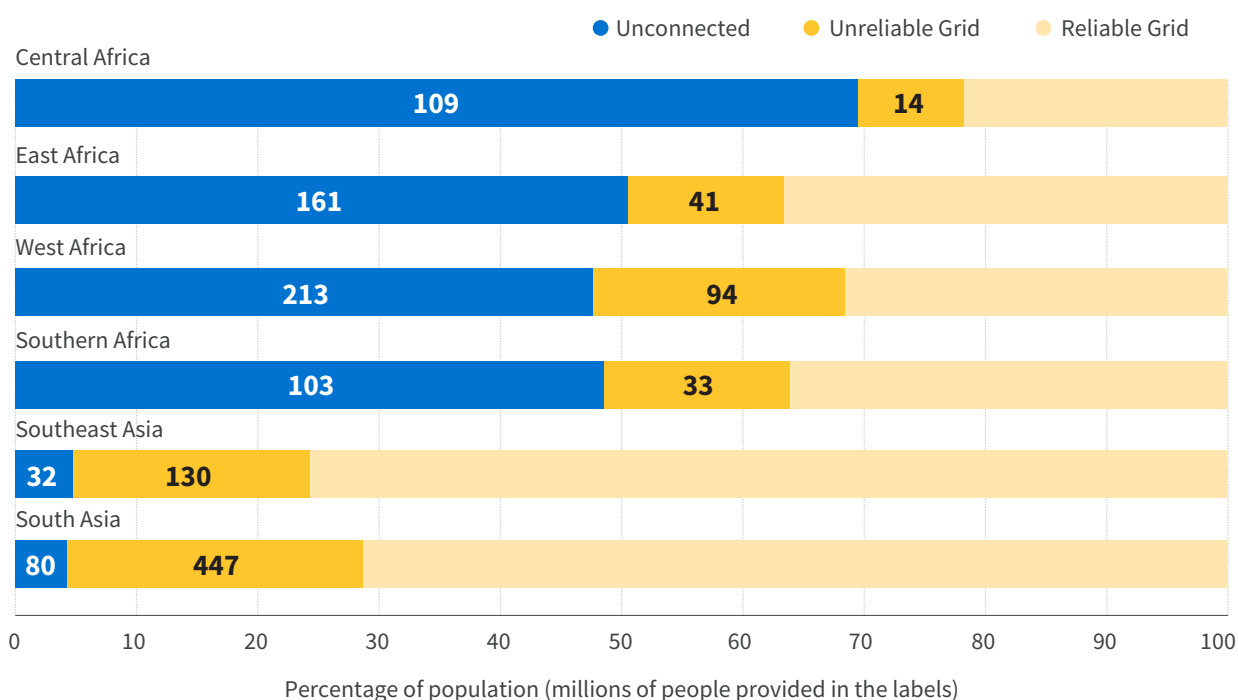

OGS already plays a crucial role in accelerating access to high-quality, reliable electricity access. In several countries, off-grid solar systems are already used as a secondary source of electricity alongside a connection to the main grid (Figure 9). For example, in South Asia – where 61% of households using an OGS product do already have a connection to the main grid – 88% of those households report using their backup solar system every day.²⁴ While the appliance markets are still relatively young and there is less evidence, a similar trend would be expected for these products. For example 28% of households using an off-grid fan in Bangladesh are also connected to the main grid.²⁵

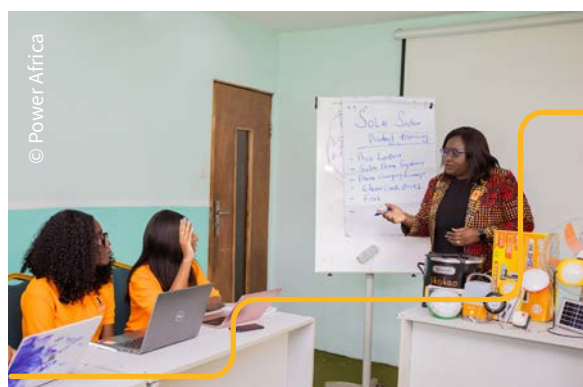

22 [Agrawal et al. \(2020\), State of Electricity Access in India: Insights from the India Residential Energy Survey \(IRES\).](#)

23 *Updated from Market Trends Report 2020, with grid reliability held the same for sub-Saharan African countries, but improving in the largest unreliable grid market of India based on CEEW survey.*

24 [GOGLA \(2020\), Powering Opportunity South Asia.](#)

25 [Efficiency for Access Coalition \(2019\), The Socio-economic Impact of Super-Efficient Off-Grid Fans in Bangladesh.](#)

Figure 9: Of households using an OGS system, share using it as a secondary source of electricity alongside e.g. a grid connection²⁶

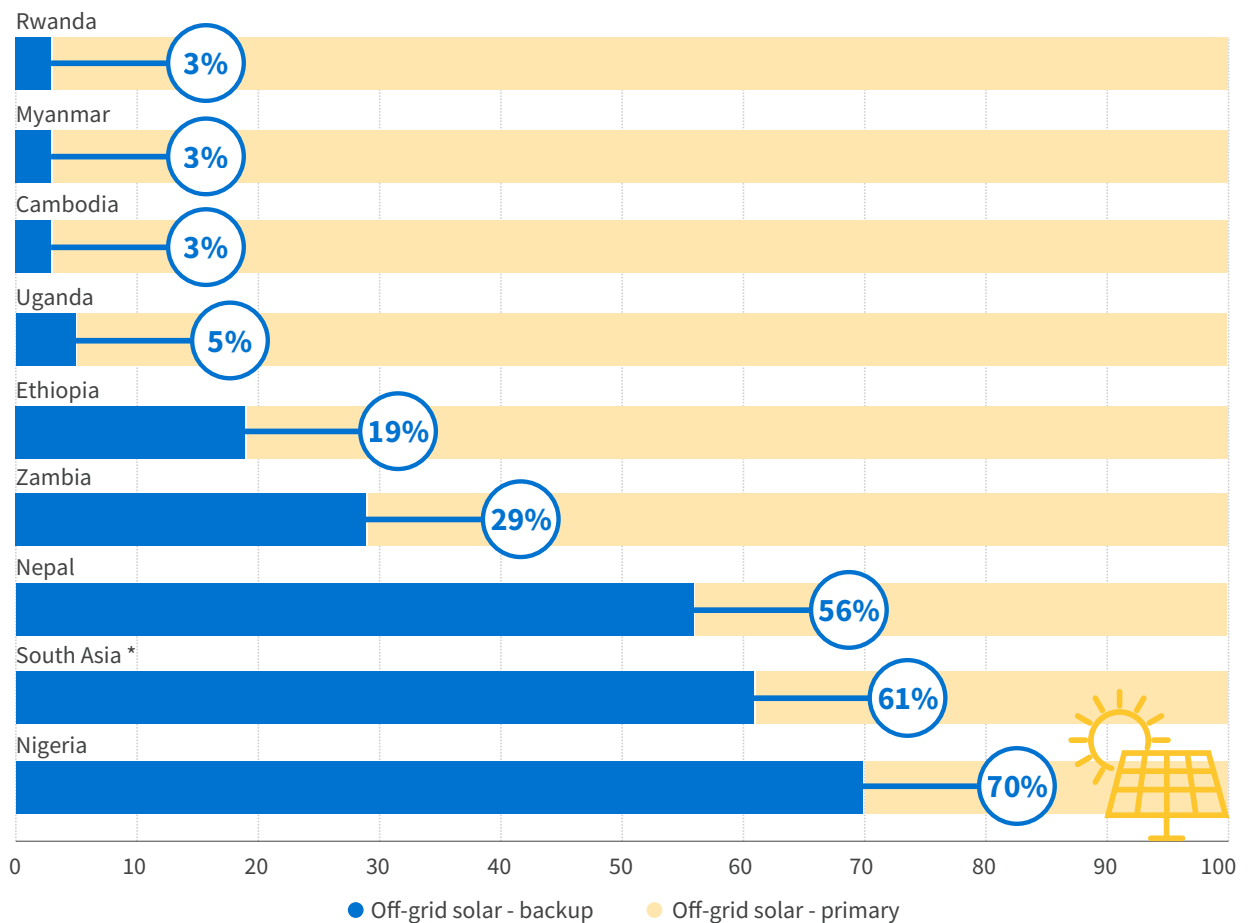

There is also a sizeable additional market opportunity for solar appliances and for productive use of energy technologies particularly in the agriculture sector.

There is significant market potential for off-grid appliances. As described in the *State of the Off-Grid Appliances Market Report (2019)*, the estimated potential market for off-grid TVs, fans, and refrigeration units (RU) was predicted to reach \$25.2 billion by 2030. This represents a large untapped market, especially in the context of the current market size for standalone off-grid appliances (\$0.7-0.8 billion - see Section 2.2 below).

In some cases, the market for off-grid appliances appears to be developing in tandem with SEK markets, but it is also emerging as a market in and of itself. This is the case for TVs and small refrigeration units, as these are largely sold bundled with SEKs. However, there has been a deviation in this trend for fans, which have developed as a successful standalone market in South Asia (see Section 5.1 for further discussion).

There is substantial potential to leverage solar for productive use across the agriculture sector. The combined addressable market potential for the use cases of cold storage and irrigation alone across sub-Saharan Africa and India is estimated at more than \$14 billion (2022). Expanding access to technologies for these use cases can immediately improve the livelihoods of about

²⁶ Analysis of MTF household survey data, * data point from *GOGIA (2020), Powering Opportunity South Asia*.

22 million smallholder farmers (SFH) across sub-Saharan Africa and India.²⁷

For cold storage technologies in sub-Saharan Africa alone, there is a potential market size of 7.4 million smallholder farmers (Figure 10).²⁸ Smallholder farmers who are off-grid or who have a weak grid connection and who operate in relevant value chains such as horticulture, dairy, and aquaculture drive most of this demand. Across the region, many face significant post-harvest losses, 40% can be attributed to a lack of temperature-controlled environments between harvesting and processing. Cooling storage solutions have the potential to reduce post-harvest losses by up to 30%.²⁹

Most smallholder farmers across sub-Saharan Africa, however, face significant challenges with affording cold storage technologies or accessing financing. For market sizing in this report, when considering affordability assumptions, the estimate of the addressable market for cold storage appliances in sub-Saharan Africa consists of 890,000 smallholder farmers, with a value of approximately \$296 million (2022).

Figure 10: Estimated total potential and addressable market for cold storage in millions of SHFs in SSA³⁰

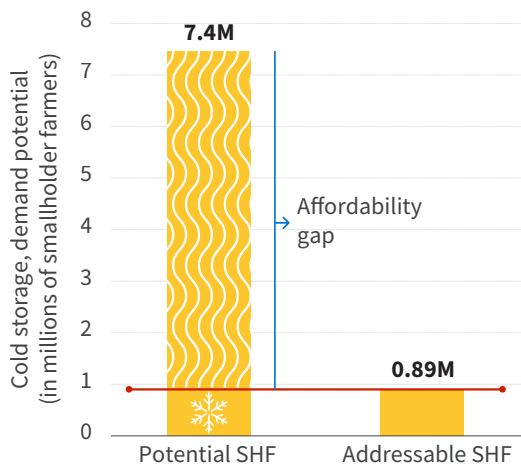

India also presents an attractive market opportunity for cold storage productive use technologies, with an estimated potential market size of 52.5 million smallholder farmers (Figure 11).³¹ Despite rapid grid expansion in India, the grid is still unreliable which has created an opportunity for OGS technologies.³² Notably, India is also one of the largest dairy markets globally although due to lack of reliable grid connections, millions of tonnes of milk is wasted or reaches the market as lower quality dairy products.³³ As such, several productive use technology companies are developing innovative solar-powered cold storage facilities to improve dairy farmers' ability to preserve larger volumes of milk, and improve farmer's incomes. These solar cold storage facilities offer a less costly alternative to diesel generators, but are often expensive to purchase upfront even with financing. Considering affordability constraints, the addressable market in India is estimated to consist of 15.8 million smallholder farmers, or \$3.1 billion (2022).

Figure 11: Estimated total potential and addressable market for cold storage in millions of SHFs in India³⁴

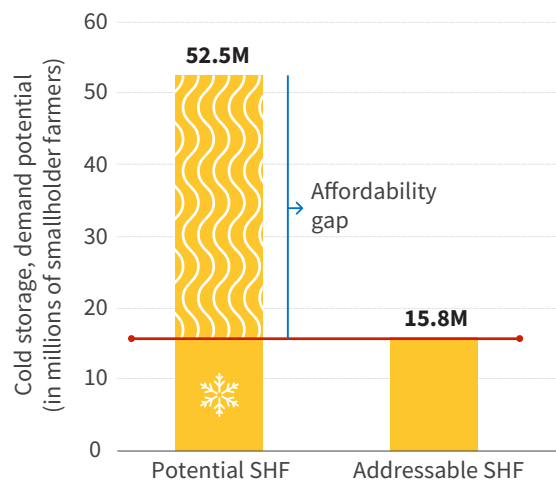

Solar water pumps is a key productive use appliance market with an estimated potential market size of 5.2 million smallholder farmers in sub-Saharan Africa (Figure 12).³⁵ Key growth drivers are increased smallholder farmer incomes, and awareness of the benefits of SWPs.

²⁷ Open Capital Advisors analysis.

²⁸ See Annex 7 - Methodology for estimating the PUE demand potential of sub-Saharan Africa.

²⁹ Shell Foundation (2019), *The Cold Chain Opportunity*.

³⁰ Open Capital Advisors analysis.

³¹ See Annex 8 - Methodology for estimating the PUE demand potential of India.

³² Climate Policy Initiative (2021), *The Future of Distributed Renewable Energy in India*.

³³ WeForum (2015), *How Milk-Chillers could Revolutionize India's Dairy Industry*.

³⁴ Open Capital Advisors analysis.

³⁵ Open Capital Advisors analysis.

Across the region, several providers have emerged, also recognizing the benefits of income generation for affordability and ability to repay consumer loans. There are an estimated 5.2 million smallholder farmers across sub-Saharan Africa in rural, off-grid areas. These grow predominantly high-value cash crops such as fruits and vegetables for export and have access to sufficient water to irrigate their farms. With affordability constraints, the addressable market potential in sub-Saharan Africa is estimated to be 0.64 million smallholder farmers, or \$684 million (2022).

Figure 12: Estimated total potential and addressable market for solar water pumps in millions of SHFs in SSA³⁶

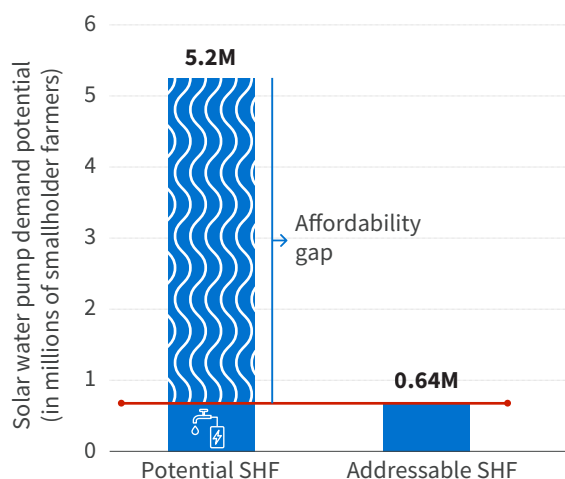

In India, there is a potential market size of 15.3 million smallholder farmer households for solar water pumps (Figure 13). The country's agricultural sector has benefitted from government subsidy programs supporting solar water pumps of different sizes, both grid-connected and off-grid, with subsidies of up to 60% of the price of standalone SWPs up to 7.5kW.³⁷ The government has been keen to provide farmers with security—as farmers can boost crop yields by up to 50% and grow water-intensive crops in the dry season with irrigation and reduce the use of fossil fuels for irrigation.³⁸ Despite government subsidies,

a significant share of Indian smallholder farmers still face affordability challenges, resulting in an estimated addressable market size of 4.6 million smallholder farmers, or \$10 billion (2022).

Figure 13: Estimated total potential and addressable market for solar water pumps in millions of SHFs in India³⁹

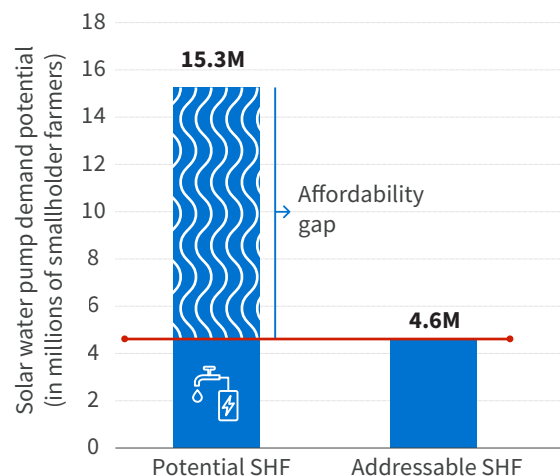

2.2 Global OGS Market Trends

The global off-grid solar market is valued at an estimated \$2.8 billion annually (2021). This includes annual estimates for both off-grid solar energy kits (including solar lanterns and multi-light systems, and solar home systems) as well as off-grid appliances, including appliances such as TVs and fans, and dedicated productive use appliances such as solar water pumps and refrigeration units. The off-grid solar energy kits market is estimated at \$2.1 billion annually, of which an estimated 4% consists of off-grid household appliances (TVs and fans) that are typically sold bundled with solar home systems (SHS) (Figure 14).⁴⁰ The standalone off-grid appliance market for TVs, fans, solar water pumps and refrigeration units not sold bundled with SHS is estimated

³⁶ Open Capital Advisors analysis.

³⁷ [Climate Policy Initiative \(2021\), The Future of Distributed Renewable Energy in India; Government of India \(2019\), PM KUSUM scheme.](#)

³⁸ [University of Cambridge \(2019\), Solar Irrigation Solutions for Smallholder Farmers in India; Council of Energy, Environment and Water \(2021\), Powering Livelihoods Globally through Clean Energy.](#)

³⁹ Open Capital Advisors analysis.

⁴⁰ Note: An estimated 83% of solar-powered TVs and 17% of fans affiliate sales in sub-Saharan Africa are bundled with solar home systems. Given lack of sufficient data on non-affiliates, we are conservatively estimating the non-affiliate appliance market segment consists mainly of sales of component-based systems i.e. no overlap between appliance sales and off-grid solar energy kit sales.

at \$0.7 billion annually.⁴¹ The 2020 *Off-Grid Solar Market Trends Report* included an estimate for the market value of the off-grid solar energy kit portion of the market, but not the off-grid appliance market segment.⁴²

Note: Section 2.2 discusses global market trends for both ‘affiliate’ and ‘non-affiliate’ products while Section 2.3 focuses on global and regional market trends for ‘affiliate’ products only. See Box 1 below for additional explanation on ‘affiliate’ and ‘non-affiliate’ products.

Figure 14: Estimated off-grid solar energy kit and appliance market turnover, annual (2021)⁴³

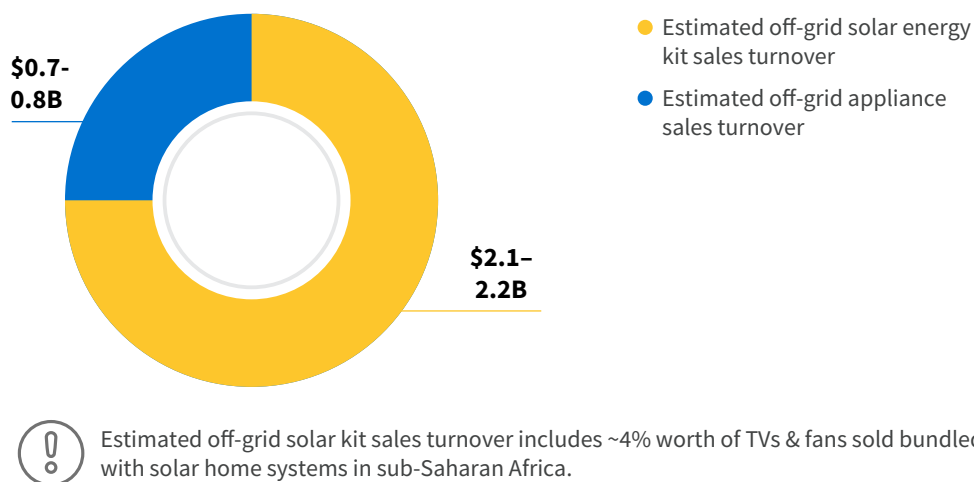

Box 1: ‘Affiliate’ and ‘non-affiliate’ products

This report distinguishes between ‘affiliate’ and ‘non-affiliate’ products.

- Affiliate products are sold by companies that are connected to any of the partner organizations involved in the semi-annual GOGLA sales data collection and which share their sales data. This includes GOGLA members, companies selling products that meet VeraSol quality standards, and appliance companies that participated in the Global LEAP Awards or are engaging with the Low Energy Inclusive Appliances (LEIA) program.
- Non-affiliate products are sold by companies that are not within the matrix of companies distributing affiliate products listed above and often include mainly component-based systems as well as plug-and-play systems. These companies selling non-affiliate products do not participate in the GOGLA sales data collection process, and generally much less is known about the quality and level of Tier access their products provide.

Based on 2022 estimates, non-affiliate products are still estimated to account for 72.1% of annual off-grid solar energy kits products sold on the market, compared to 71.5% in 2020.⁴⁴ Regarding market turnover, non-affiliates account for an estimated 62% of the total, driven by cash sales of solar lanterns and multi-light system solar products (Figure 15). (See Methodology in Annex 5 and Section 2.4 Product Types and Pricing for additional insights).

⁴¹ Note: Off-grid appliance market data is extremely limited compared to the off-grid solar energy kit product category. The main sources of information used consisted of published reports available online including CLASP, VeraSol, GOGLA, internal firm knowledge as well as consultations. Key stakeholders approached for these consultations include appliance manufacturers and distributors based in key countries in sub-Saharan Africa and Southeast Asia. The analysis and insights included in this report thus reflects our understanding of key trends based on data available as at the time of writing.

⁴² World Bank, IFC, GOGLA (2020), *Off-Grid Solar Market Trends Report 2020*.

⁴³ Open Capital Advisors analysis.

⁴⁴ World Bank, IFC, GOGLA (2020), *Off-Grid Solar Market Trends Report 2020*; Note: This is based on analysis of multiple sources of data and information, including: [1] MTF household survey data (11 countries), from which we estimate the total live products (solar lanterns and multi-light systems and SHS) per target country based on data on solar panel wattage; [2] GOGLA annual sales data and semi-annual sales and impact data reports; [3] Country assessments published by Lighting Global, Ipsos, and other organizations; and [4] Industry interviews and other secondary sources. See Annex 5 for additional insights.

The updated estimate largely results from the inclusion of new data sources (i.e., compositional effects), rather than from a change in the market. This report incorporates newer data from studies conducted in Malawi, Nigeria, and Papua New Guinea, where non-affiliate products account for an estimated 36%, 73%, and 93% of the total OGS market, respectively (Figure 16). (See Methodology in Annex 6 for additional insights).

Figure 15: Affiliate versus non-affiliate share of global sales volume & market turnover⁴⁵

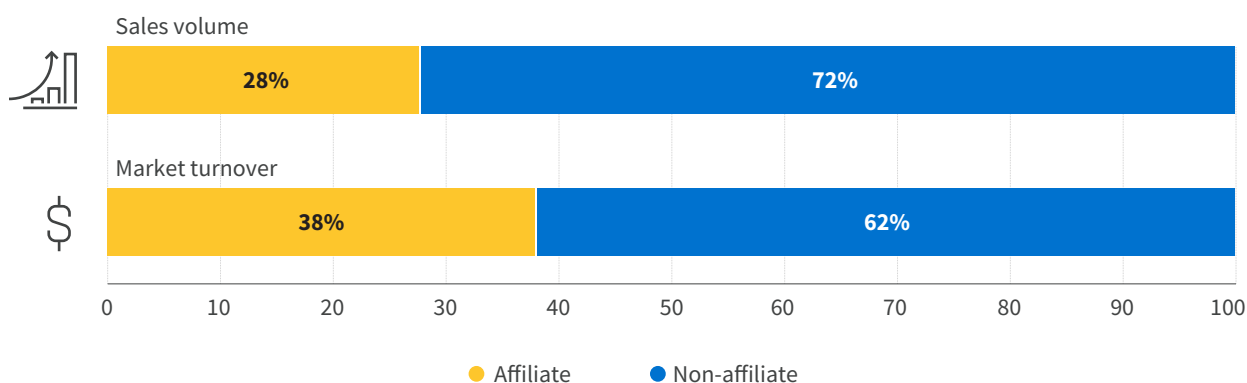
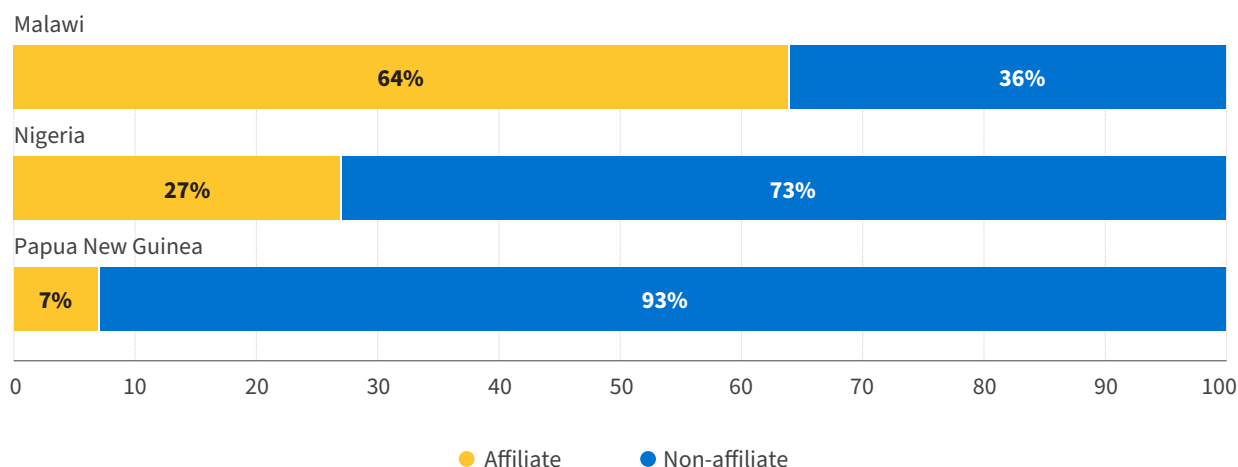

Figure 16: Affiliate versus non-affiliate market share in Nigeria, Malawi, and Papua New Guinea⁴⁶



2.2.1 Global Solar Energy Kit Sales Volumes and Market Turnover

Unit sales for solar energy kits declined 22% in 2020 compared to 2019, largely due to the COVID-19 pandemic, but recovered by 10% from 2020 to 2021. This was mainly due to a strong recovery in sales of solar lanterns and multi-light systems sales (Figure 17). Global sales of solar lanterns and multi-light systems declined by about 22% between 2019 and 2020 due to a decrease in cash sales,

before increasing by 13% between 2020 and 2021. Global SHS unit sales also declined from 2019 to 2020 (21%), and have yet to fully recover to pre-pandemic levels, with unit sales increasing only 7% between 2020 and 2021.

The global solar energy kit market is now estimated at \$2.1 billion annually (2021), with an increase from 2020 to 2021 signaling the beginnings of recovery (Figure 18). Supply chain disruptions related to the COVID-19 pandemic have raised manufacturing and distribution costs across the sector, leading to a (moderate) increase in average prices across most product segments and especially for higher-value SHS. Higher prices, coupled with depressed

⁴⁵ Open Capital Advisors analysis.

⁴⁶ Open Capital Advisors analysis.



consumer incomes due to pandemic-related economic challenges, suppressed demand over the past two years. Sales volumes have rebounded since 2020, but not yet to 2019 levels, and the faster rebound of the lower cost solar lanterns and multi-light systems compared to higher cost SHS resulted in a 7% increase in market value for solar energy kits, compared to the 10% increase in volumes. In particular, cash sales for SHS remain depressed, negatively impacting market value (see Section 2.3 Insights from the Affiliate OGS Market for additional insights).

After a 22% decline in solar energy kit sales in 2020, the sector recorded a 10% increase in sales in 2021, indicating the onset of a recovery from the impacts of COVID-19. The global solar energy kit market was valued at an estimated \$2.1 billion in 2021.

Figure 17: Global annual sales estimates of solar energy kits, including affiliate and non-affiliate sales (2010-2021)⁴⁷

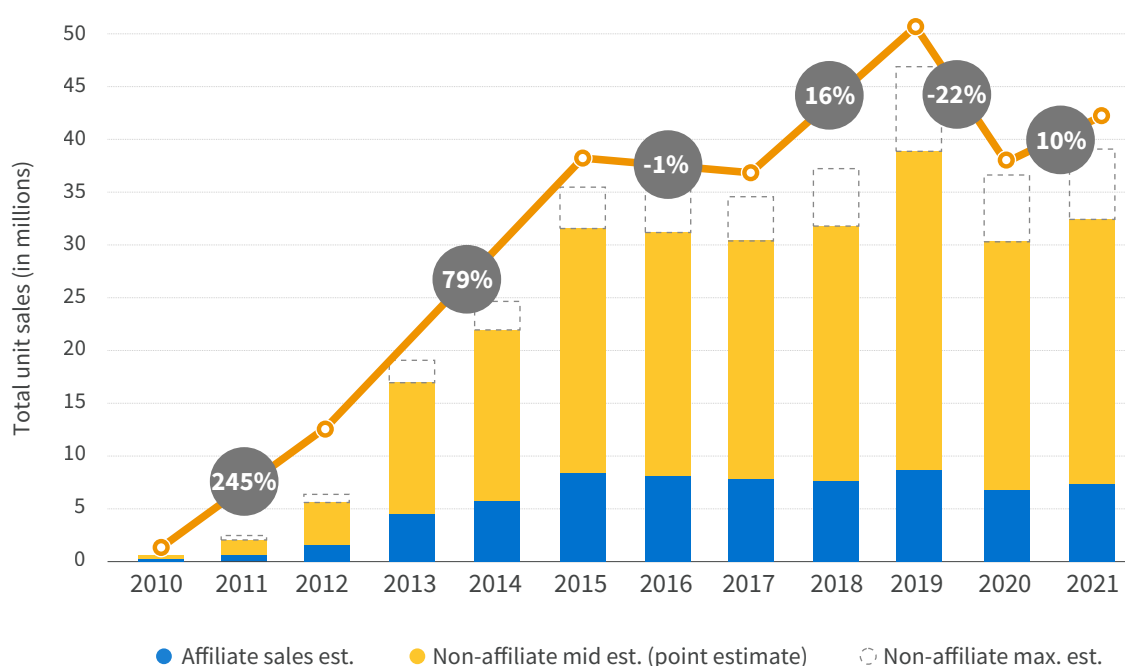

© Power Africa

⁴⁷ Open Capital Advisors analysis.

Figure 18: Estimated solar energy kit annual market turnover (2018-2021)⁴⁸

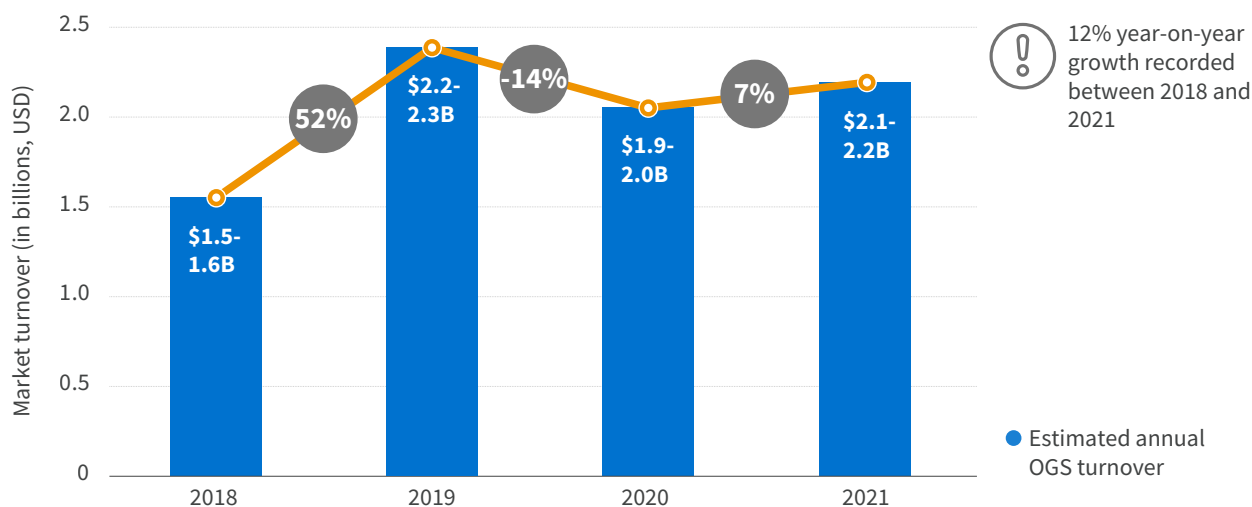

2.2.2 Global Appliance Sales Volume and Market Turnover



Based on an estimated 5 million unit sales in 2021, the annual market for off-grid solar appliances is estimated at \$0.7 billion and is yet to recover from a 19% decline in annual turnover since 2019, indicating sustained negative impacts of COVID-19 on the sector.⁴⁹

Annual unit sales of off-grid appliances declined 21% between 2019 and 2021, falling from 8 million units to 5 million units sold in each year respectively (Figure 19). Pre-pandemic, this segment posted an estimated 73% year-on-year sales growth between 2018 and 2019, driven by sales of household appliances such as TVs and fans (note: affiliates data collection for PUE appliances only began in 2018 and it is estimated that affiliate sales data in that year was significantly under-reported, potentially explaining the significant increase in market turnover between 2018 and 2019). Since 2020, aggregate sales of off-grid solar appliances have declined by 21% per year as effects of the pandemic impacted the sector, higher average prices and reduced overall product affordability.⁵⁰ (Note: the [2019 State of the Off-Grid Appliance Market report](#), which analyzed global trends in the off-grid appliance sector, estimated affiliate sales account for between 20% and 50% of total appliance market sales, a wide range in a key assumption that contributed to the wide ranges for the global appliance sales estimates).

⁴⁸ Note: SEK sales volumes declined by 22% (2019-2020) then increased 10% (2020-2021) although this recovery is yet to bring total sales to pre-pandemic (2019) levels. More specifically, solar lanterns and multi-light system sales declined 22% (2019-2022), then increased 13% ('20-21) while SHS sales declined 21% then increased by 7% over the same period. In aggregate these solar lanterns and multi-light systems and SHS changes then contributed to combined changes in SEK sales volume and turnover i.e. even while SHS only increased by 7% (2020-2021) the higher increase from solar lanterns and multi-light systems (13%) raised the overall SEK growth to 10% over the same period.

⁴⁹ Note: Off-grid appliances refers to solar-powered appliances that are energy-efficient and designed to run on lower-load energy systems, are typically compatible with direct current (DC) systems, but also include alternating current (AC) appliances combined with inverters. These include both household appliances (i.e. fans and televisions) and PUE appliances (i.e. water pumps and cold storage) appropriate for use in off-grid and unreliable or 'weak' grid contexts where standalone solar energy systems are insufficient to power conventional appliances.

⁵⁰ Note: Due to significant data limitations, global appliance sales trends mainly reflect sales trends in the affiliate market; see Section 2.3 Insights from the affiliate market for additional insights.

Figure 19: Estimated appliance annual sales volumes (2018-2021)⁵¹

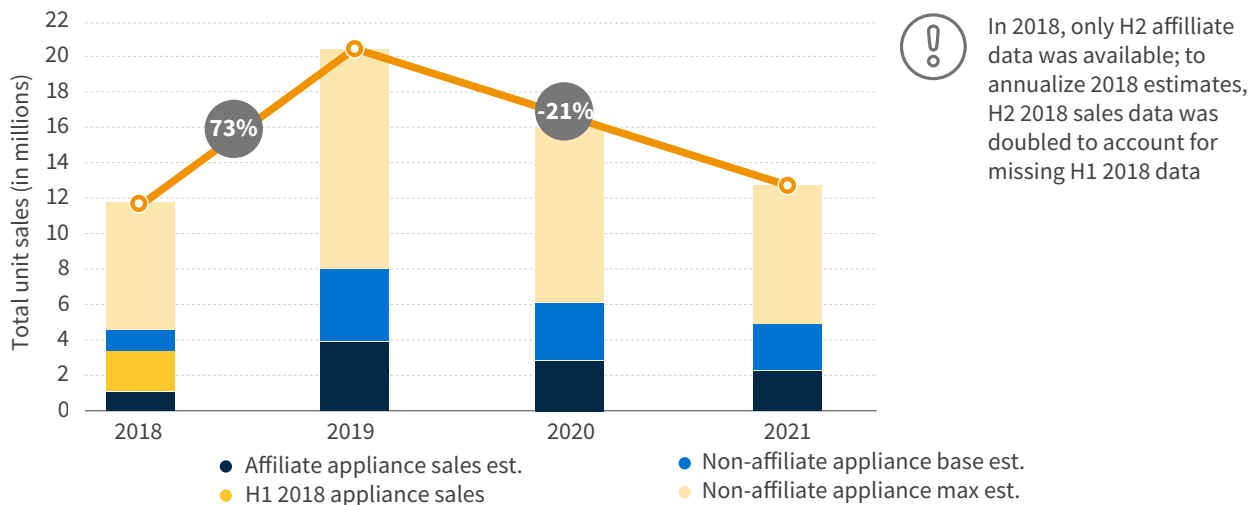

The resulting estimate for the global market turnover for off-grid appliances analyzed in this report is \$0.7 billion annually (2021) (Figure 20).⁵² Overall, year-on-year appliance market turnover declined 19% between 2019 and 2021, attributed largely to the COVID-19 pandemic and specific declines in appliance cash sales. Though

PAYGo demonstrated resilience with a 3% increase over the period, cash sales still account for a clear majority of annual market turnover. Note: the global appliance market turnover comprises both affiliate and non-affiliate product sales (see Box 1 for additional explanation).

Figure 20: Estimated appliance annual market turnover (2018-2021)⁵³

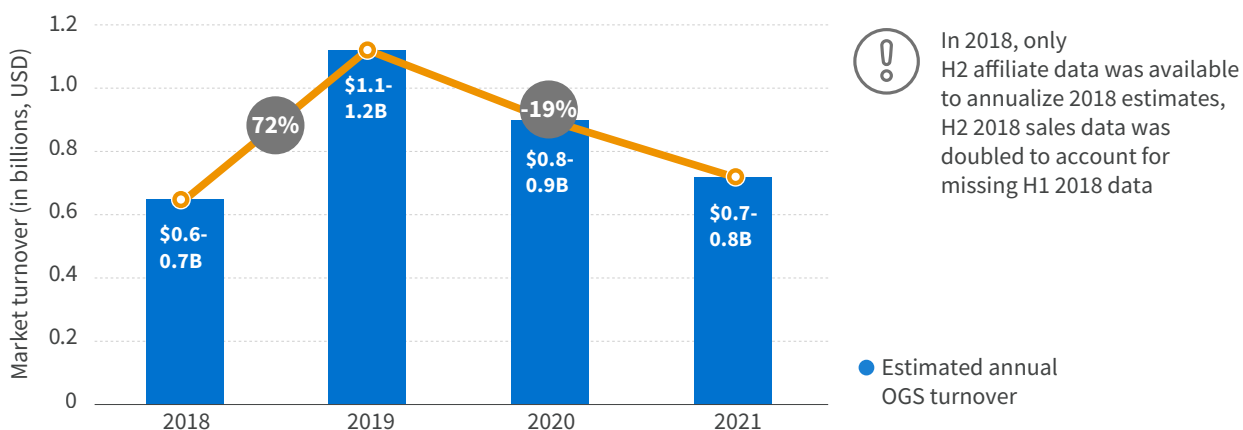

⁵¹ Note: Affiliates data collection for off-grid appliances only began in 2018 and it is estimated that affiliate sales data in that year was significantly under-reported (and only included H2 2018 sales estimates) an issue that has persisted in subsequent years; CLASP estimates less than 40% of affiliate companies reached out share their sales data. Additionally, due to significant data limitations, we have built off assumptions of affiliate vs. non-affiliate market proportions used in the 2019 State of the Off-Grid Appliance Market report which analyzed global trends in the off-grid appliance sector and estimated affiliate sales account for between 20% and 50% of total appliance market sales and hence assumed non-affiliates account for between 50% (base scenario) and 80% (maximum scenario) of total appliance market sales. See discussion on additional methodology assumptions in Annex 5.

⁵² Note: Market turnover was derived using a multi-tiered approach. We used the minimum prices estimates from our price ranges listed in section 2.4 to calculate an average weighted for solar lanterns and multi-light systems, and SHS products using volume proportions of GOGLA affiliate sales. We then multiplied our average solar lanterns and multi-light systems, and SHS pricing by global sales volumes to estimate an annual market turnover for solar lanterns and multi-light systems, and SHS products. See additional discussion in Annex 5 for estimating global OGS market value and sales volumes.

⁵³ Open Capital Advisors analysis.

Among the off-grid appliances analyzed in this report, TVs and fans have the highest customer demand.⁵⁴ TV sales have consistently accounted for about half of all appliance sales (49% in 2021) while fan sales account for about 49% of reported global appliance sales in 2021. Notably, TV sales contribute the majority of the appliance market turnover, increasing from 69% in 2018 to 74% in 2021 (Figure 21). This increasing proportion of TV sales is driven by higher sales volumes globally. (See Section 2.3 Insights from the Affiliate OGS Market for additional insights).⁵⁵

Comparatively, sales for larger productive use of energy (PUE) appliances are much lower, despite significant market potential (See Section 2.1). For example, in sub-Saharan Africa and Southeast Asia, several companies have adopted the cooling-as-a-service business model, offering cold storage space to smallholder farmers for their perishable produce at a cost of \$0.50 per 20-kg crate per

day to help tackle high post-harvest losses, a key driver for food insecurity across both regions.⁵⁶ In Southeast Asia, manufacturers are able to sell often costly refrigerated vehicles to larger last mile distributors (LMDs) given their ability to pay and preference to pay for higher quality cold storage solutions.⁵⁷ Nonetheless, high product prices are a key limiting factor impacting sales of refrigeration units and solar water pumps (See Section 2.3 Insights from the Affiliate OGS Market and 2.4 Global OGS Product Pricing Trends for additional insights).

PUE appliances, however, account for more significant market turnover compared to household appliances despite their lower overall proportion of sales volume. While both refrigeration and solar water pumps account for a very small portion of appliance sales volumes, both product segments account for a relatively large portion of appliance market turnover, owing to their higher prices.

Figure 21: Comparison of annual estimates of appliance market turnover (2018-2021)⁵⁸

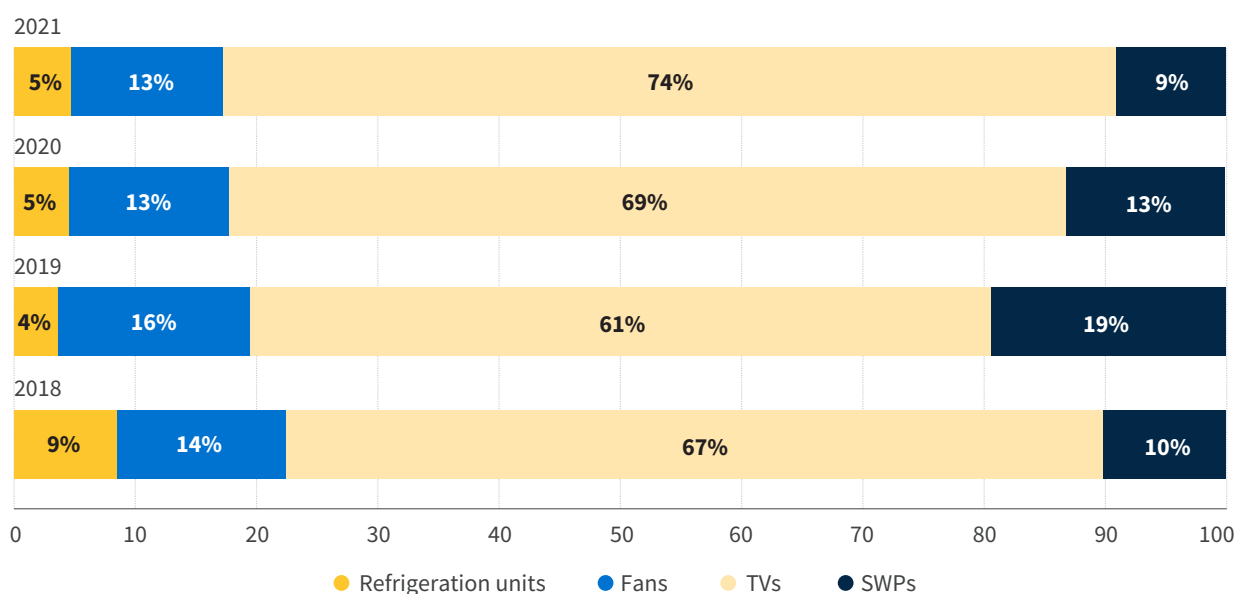

54 [Efficiency for Access Coalition \(2021\), Televisions Solar Appliance Technology Brief](#).
 Note: Household appliances account for significant volume of reported sales compared to productive use appliances due to their lower average prices but the PUE market segment is expected to continue accounting for a growing market share as the sector expands. Also across sub-Saharan Africa more than 80% of TVs are sold bundled in SHS kits; fans are sold in large volumes in Asia.

55 [Efficiency for Access Coalition \(2021\), Fans Solar Appliance Technology Brief; GOGLA \(2021\), Global Off-Grid Solar Market Report Semi-Annual Sales & Impact Data H1](#)

56 [ColdHubs \(2020\), How ColdHubs won the 2020 Global CaaS prize](#).

57 [Open Capital Advisors consultations](#).

58 [Open Capital Advisors analysis](#).

2.3 Insights from the Affiliate OGS Market

Semi-annual sales volumes data collected from GOGLA affiliates offers more detailed insights into the sector during the last two years. While not representative of the entire sector, affiliate data is included in this report as it clarifies trends at a more granular level.

Affiliate sales reached their highest volumes ever in 2019, and a 2018-2019 annual growth of 13%⁵⁹ put the industry on track to maximize its contribution to meeting SDG7 targets. The COVID-19 pandemic, however, slowed the global OGS market (Section 2.2), affiliates included. Global figures indicate a potential path to recovery, but these headline figures hide an uneven and fragile recovery. Data and insights from GOGLA affiliates show considerably varied trends since 2019, not only along country lines but also from company to company. Contributing factors include company maturity, business model, product lines, markets of operation, and ability to raise funds. Of the 54 companies reporting sales in both the second half of 2019 and the second half of 2021, 52% reported higher sales in 2021 than in 2019.⁶⁰

2.3.1 Solar Energy Kits Affiliate Market Trends

a. Global



Global affiliate sales volumes decreased by 22% in 2020 before growing by 12% in 2021, driven by increased PAYGo sales, including a growing PAYGo solar lanterns segment.

Cash and PAYGo affiliate sales volumes demonstrate sales across all product categories fell initially during the pandemic, but that PAYGo was more resilient and has already returned to growth. While global affiliate sales decreased across all product categories in 2020, multi-light systems (3-10 Wp) and small SHS (11-20 Wp) recovered and outgrew 2019 sales in 2021. Global affiliate sales of solar lanterns have returned to growth, but have not reached pre-COVID levels. Sales of SHS above 20 Wp have yet to return to growth, with lower sales in 2021 than in 2020.⁶¹ Sales of products providing Tier 1 access are recovering, while sales of products providing Tier 2 access are yet to show clear signs of recovery (see Section 2.1) (Figure 22).⁶²

Figure 22: Global affiliate sales volumes of OGS products by category (2017-2021) (in thousands)⁶³

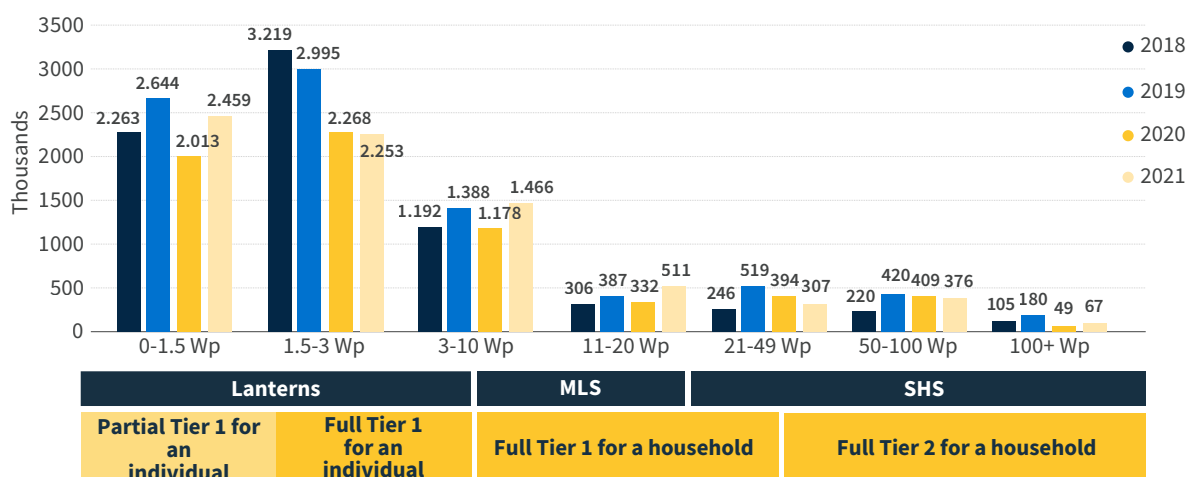

59 GOGLA analysis of data collected for the Global Off-Grid Solar Sales and Impact Reports 2016-2021.

60 *Ibid.*

61 *Ibid.*

62 The Tiers of energy access are described in the Multi-Tier Framework (MTF), developed by ESMAP. The MTF represents an effort to build global, aggregable metrics and a database for evaluating electricity access. Energy access is measured on a tiered spectrum, from Tier 0 (no access) to Tier 5 (the highest level of access).

63 GOGLA analysis of data collected for the Global Off-Grid Solar Sales and Impact Reports 2016-2021.

Resilient PAYGo sales over the last two years sees PAYGo representing an increased share of affiliate sales for SHS, MLS and lanterns. In 2021, 37% of all sales were through PAYGo (Figure 23). This increases to 47% in sub-Saharan Africa where PAYGo is far more prevalent than in other key markets in Asia. Globally, the share of SHS sold through PAYGo increased from 70% in 2019 to 84% in 2021, while the share of MLS and lanterns sold through PAYGo increased from 16% in 2019 to 27% in 2021. Among them, the share of solar lanterns with phone charging sold by PAYGo grew from 12% in 2019 to 38% in 2021 to total 859,000 units.⁶⁴ The resilience of PAYGo sales compared to cash sales and the growth of PAYGo for smaller product categories highlights the increased pressure on affordability of electricity access solutions caused by the COVID-19 pandemic's economic consequences.

Figure 23: Share of PAYGo solar energy kits sales volumes as percent of total solar energy kit sales volumes (2018-2021)⁶⁵

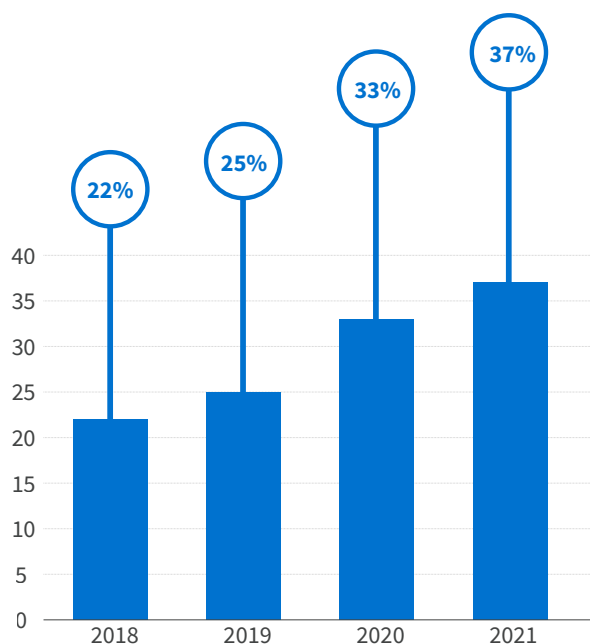

The COVID-19 pandemic has accelerated regional trends such as declining sales in South Asia, a slowdown in mature East African markets, but growth in key West and Central African markets.

The COVID-19 pandemic has accelerated regional trends such as declining sales in South Asia, a slowdown in mature East African markets, but growth in key West and Central African markets

The relative importance of key regional and country markets for affiliates has shifted (Figure 24).

- In South Asia, where total volumes are driven by the Indian market, sales have followed a structural declining trend since 2017 following grid expansions.
- East Africa, where Kenya is the most important market, saw strong growth through 2019. After a significant dip in 2020, the region is on a slow path to recovery.
- In West Africa, sales grew despite the COVID-19 pandemic. Strong growth in Nigeria is the driver behind this trend.
- Similarly, although more nascent, key markets in Central Africa, such as Cameroon, have remained on a growth trajectory throughout the COVID-19 pandemic.

The following subsections share further analysis for each region.



⁶⁴ GOGLA analysis of data collected for the Global Off-Grid Solar Sales and Impact Reports 2016-2021.

⁶⁵ GOGLA analysis of data collected for the Global Off-Grid Solar Sales and Impact Reports 2016-2021. Data collection for affiliates only enables distinction between cash and PAYGo starting in 2018. Prior to 2018, volumes of cash and PAYGo were aggregated without distinction.

Figure 24: Evolution of regional market shares of total affiliate sales of solar energy kits (columns) and total units sold by affiliates in India, Kenya, Nigeria and Cameroon (lines) (2018-2021)⁶⁶

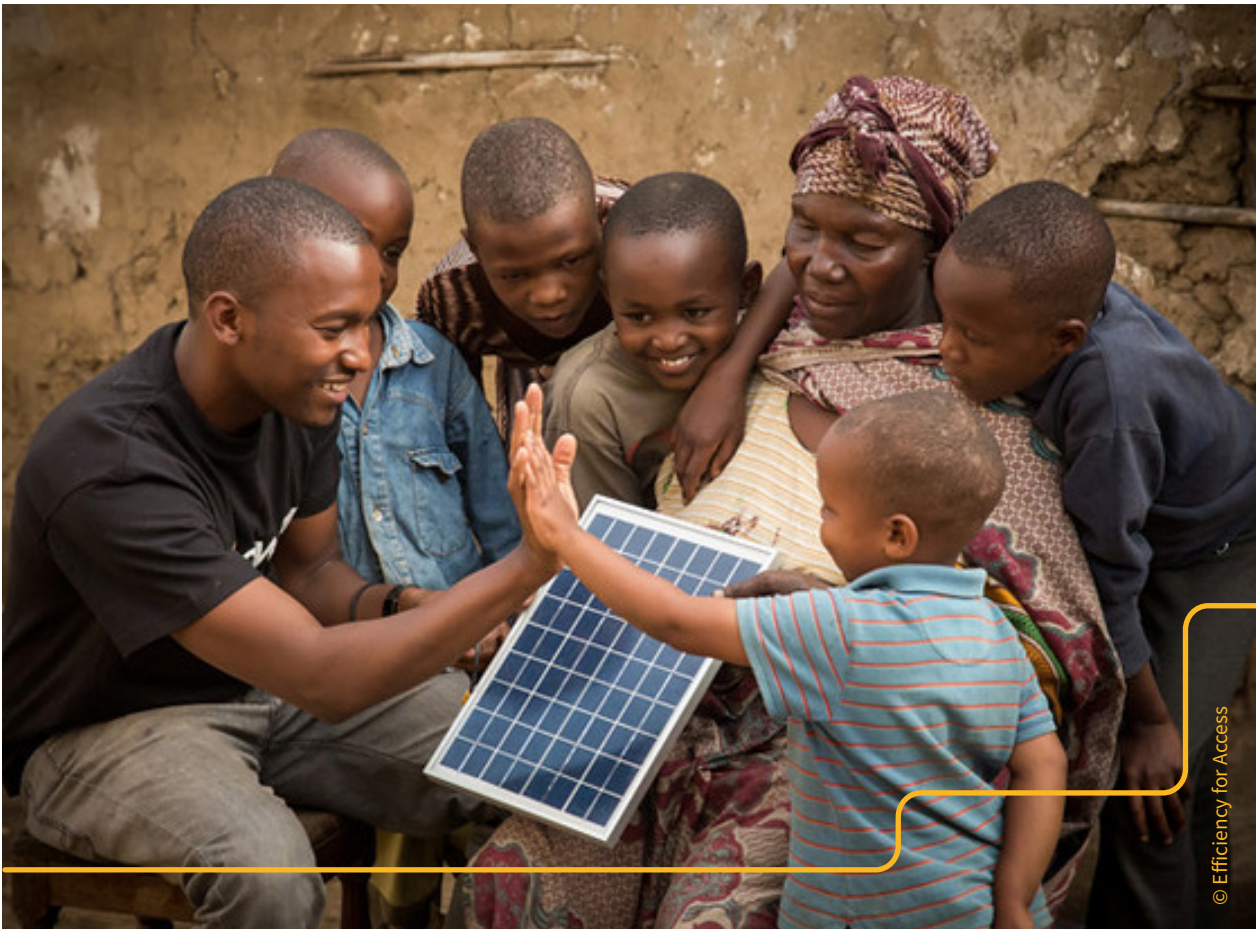
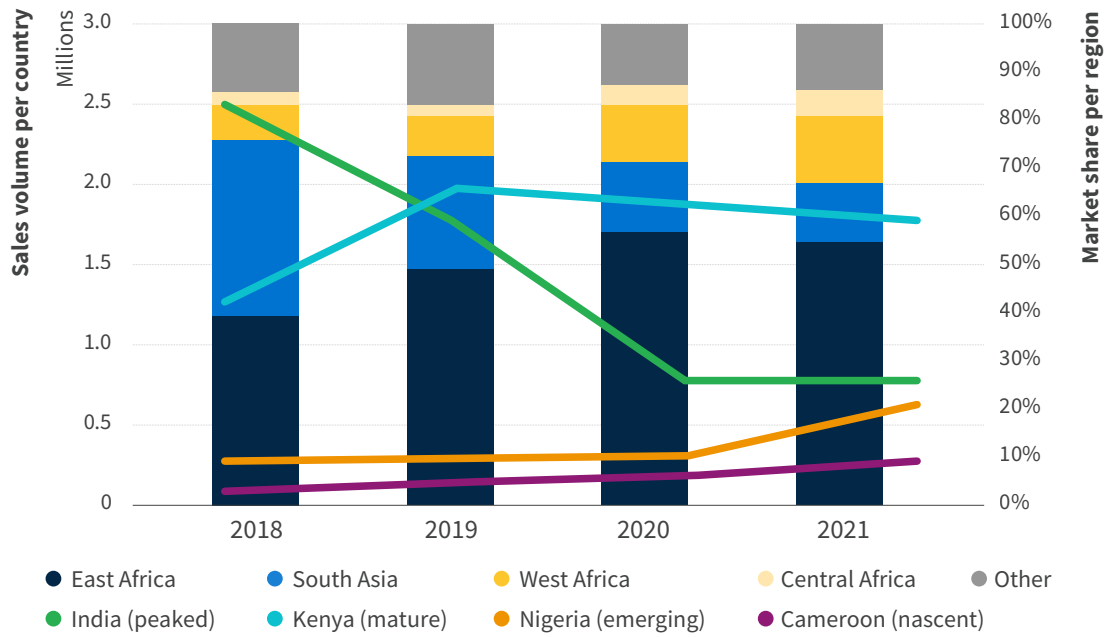

© Efficiency for Access

66 GOGLA analysis of data collected for the Global Off-Grid Solar Sales and Impact Reports 2016-2021.

b. South Asia

Overall, volumes in South Asia are driven by the Indian market. Historically the largest market in volumes of affiliate sales, the Indian market consists largely of sales of solar lanterns either sold cash or through microfinance institutions (MFIs).

Grid extension in India has led to declining solar lantern sales, and sales of solar home systems, while growing

again in South Asia, represent only a small share of total volumes (Figure 25). Off-grid solar companies have diversified their product portfolio to include new products adapted to a weak grid setting, such as inverters and inverter bulbs.⁶⁷ Although sales are expected to grow relative to 2020 levels, they will likely not reach pre-COVID-19 levels. A market remains for solar lanterns and SHS in India for outdoor use cases or to complement the grid or mini-grid as a back-up or even as a primary source.⁶⁸

Figure 25: Affiliates sales volumes of solar energy kits in South Asia (2018-2021)⁶⁹

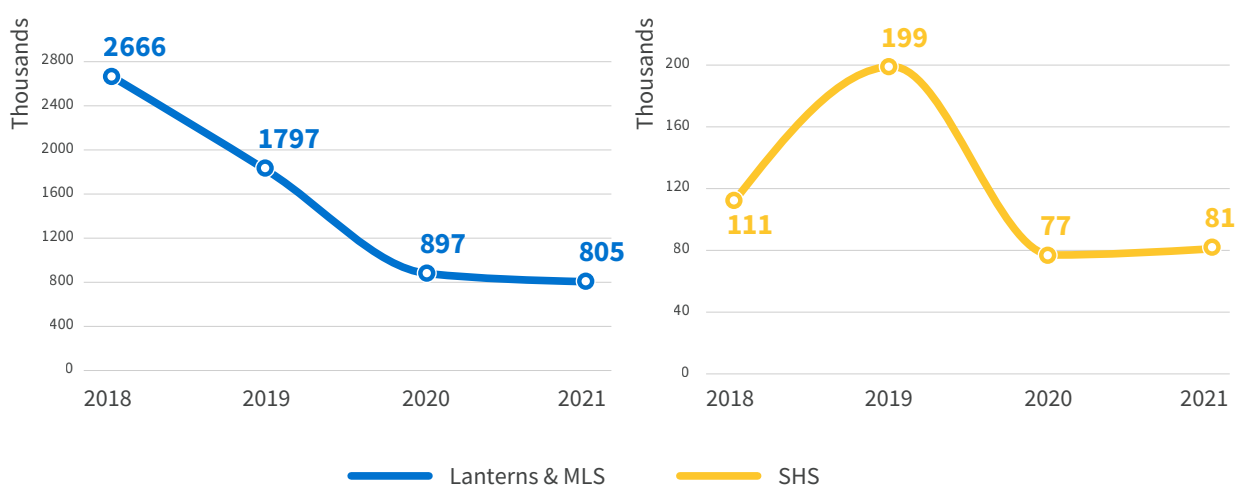

c. East Africa

East Africa, particularly Kenya, has been central to key developments for the off-grid solar industry, including PAYGo solutions and modern SHS. Since 2018, East Africa has been the largest market by volume for affiliates, ahead of South Asia. With proportionally higher PAYGo and SHS sales, East Africa represents an important market in terms of total value.

While the OGS industry in the region returned to growth in 2021, this growth has been fragile and unevenly distributed. In Kenya, sales were stable in 2020 compared to 2019, but reported sales are lower in 2021 as companies weather the protracted effects of the COVID-19 pandemic (see Section 5.3). In Ethiopia, COVID-19, conflict and unresolved foreign exchange restrictions have led sales to

decline continuously since the end of 2019. On the other hand, younger markets such as Malawi, Mozambique and Madagascar are seeing strong growth in sales of off-grid lighting products. In the case of Mozambique and Madagascar, support from intervention programs has been a key driver.⁷⁰

Growth in East Africa in 2021 was largely driven by lanterns and multi-light systems, notably through increased sales of PAYGo solar lanterns. PAYGo sales in East Africa recorded their highest level yet with 1.87 million units sold in 2021. However, SHS sales have yet to return to growth and recorded substantially lower sales in 2021 than in 2020 (Figure 26).

67 Sales of these products are currently not captured by the GOGLA sales data collection.

68 Harrington et al. (2020), *Variation in Rural Household Energy Transitions for Basic Lighting in India*.

69 GOGLA analysis of data collected for the Global Off-Grid Solar Sales and Impact Reports 2016-2021.

70 Madagascar: Off-Grid Market Development Fund (OMDF) offering RBF and debt funding by the Government of Madagascar, funded by the World Bank and implemented by Bamboo Capital Partners. Mozambique: BRILHO program financed by FCDO and Sweden, and implemented by SNV. Provides funding (catalytic grants and RBF) and technical assistance to support businesses in the off-grid sector (SHS, clean cooking and mini-grids) since 2019.

Figure 26: Affiliates sales volumes of solar energy kits in East Africa (2018-2021)⁷¹

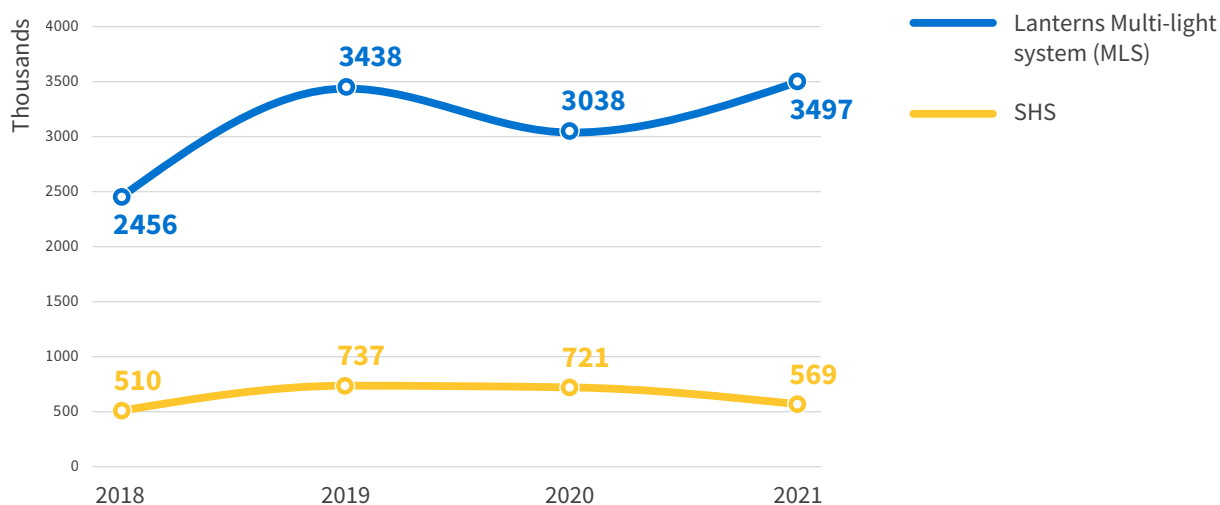

d. West Africa

West Africa, especially Nigeria, has become a new growth driver for the industry since 2019, particularly in sales of SHS. Prior to 2019, West Africa was still perceived as a relatively new market for off-grid solar, with companies operating in East Africa progressively exploring market entry. Since 2018, affiliate sales, both cash and PAYGo, have shown strong growth in West Africa with cash sales growing 31% and PAYGo recording a staggering 178% growth. Lanterns and multi-light systems sales, which declined between 2016 and 2018, have rebounded above their 2016 level, while SHS sales were multiplied by 1.87 between 2018 and 2021 (Figure 27).⁷² Overall, when compared to East Africa, SHS represent a much larger share of affiliate sales in West Africa.

Nigeria represents more than half of affiliates' sales in West Africa in 2021, and affiliate sales reported in Nigeria were particularly high in 2021. Strong growth in Nigeria is linked to multiple factors including a large untapped potential market, increasing diesel prices in a market where generators are often used as a back-up to a weak grid. The implementation of the Nigeria Electrification Program has also contributed, which includes RBF for off-grid solar and is implemented by the Rural Electrification Agency with funding from the World Bank and the African Development Bank (see Section 5.1).

Trends in most other West African markets have been less consistent, with the majority of markets yet to show a solid return to growth as of 2021.

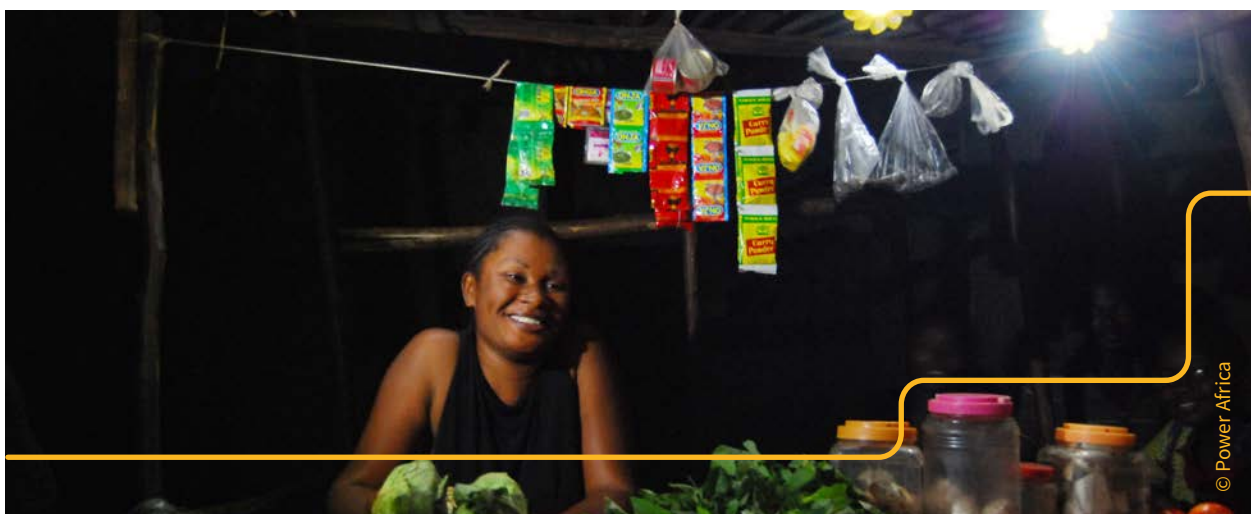

© Power Africa

⁷¹ GOGLA analysis of data collected for the Global Off-Grid Solar Sales and Impact Reports 2016-2021.

⁷² Ibid.

Figure 27: Affiliates sales volumes of solar energy kits in West Africa (2018-2021)⁷³

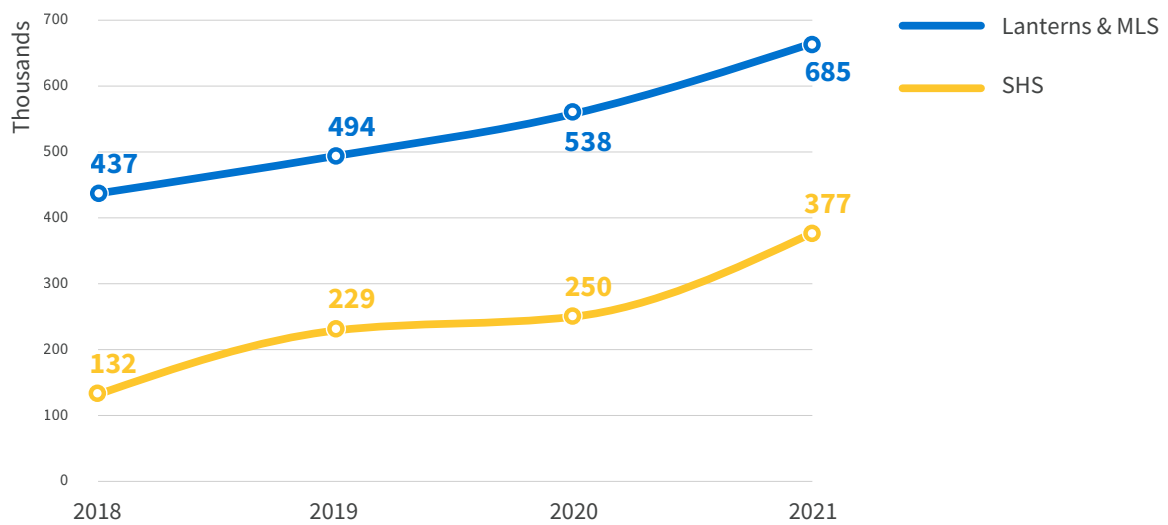

e. Central Africa

Sales data from affiliates for the region remains far lower than sales recorded in East or West Africa. However, recent data highlights potential for growth (Figure 28). Key markets for SEKs in the region are the DRC and Cameroon. Between 2018 and 2021, cash sales grew by

103% to close to 300,000 units, while PAYGo sales grew by 178% reaching 115,000 units. During the same period, lanterns and MLS sales grew 98%,⁷⁴ and SHS sales grew by 450%.⁷⁵ Further data collection will clarify if the high volume of smaller products sold in 2021 is a peak or indicative of a more significant trend.

Figure 28: Affiliates sales volumes of solar energy kits in Central Africa 2018-2021⁷⁶

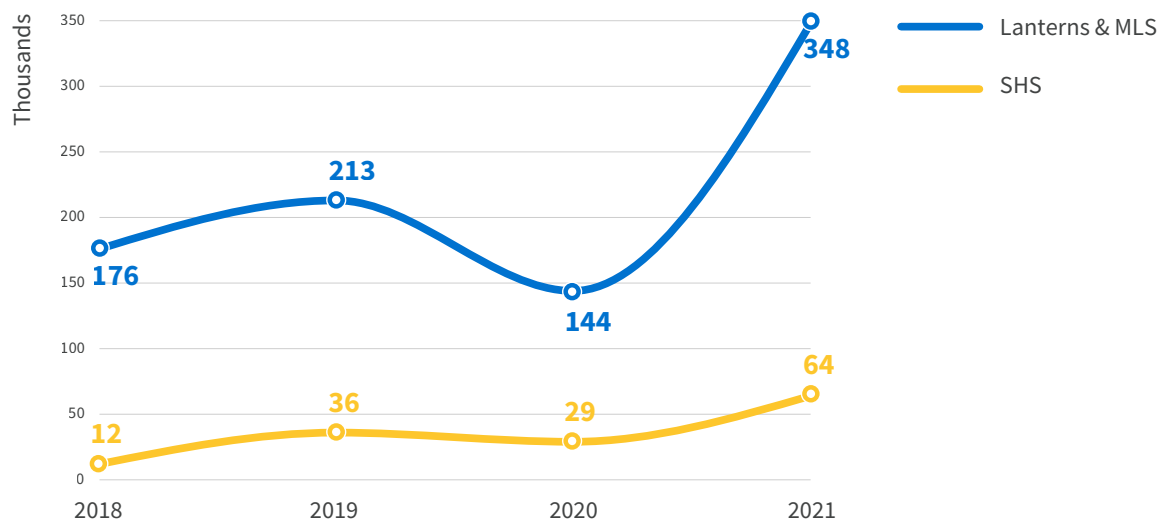

⁷³ GOGLA analysis of data collected for the Global Off-Grid Solar Sales and Impact Reports 2016-2021.

⁷⁴ Solar lanterns and multi-light systems sales volumes for Central Africa have included peaks in the past (e.g. over 300,000 units sold in 2017) and further data collection will be needed to confirm positive trends.

⁷⁵ GOGLA analysis of data collected for the Global Off-Grid Solar Sales and Impact Reports 2016-2021.

⁷⁶ Ibid.

2.3.2 Appliance Affiliate Market Trends



Affiliate sales of appliances have decreased over the last two years as a result of supply chain disruptions and lower customer ability to pay, particularly for larger productive appliances such as refrigeration units and solar water pumps.

Appliance sales data collected from affiliates focuses on four key appliances: TVs, fans, refrigeration units (RUs) and solar water pumps (SWPs). Data on appliances were collected starting in 2018, but the number of companies participating in data collection remains limited, especially for RUs and SWPs. Limitations to the data are highlighted below.⁷⁷

a. TVs

Affiliates' TV sales are mostly reported in sub-Saharan Africa by PAYGo companies selling SHS bundled with TVs. TVs sold via PAYGo may be part of a kit or an up-sell to an existing SHS customer. Large TVs (24-29") are the most popular and extra-large TVs (30"+) are increasingly popular, while sales of medium (18-23") and small TVs (<18") are declining. This reflects customer preference for larger TVs and improved efficiency of larger sets, which now use similar electricity consumption to smaller TVs.

Figure 29: Affiliates sales volumes of TVs in East and West Africa (2019-2021) (thousands)⁷⁸

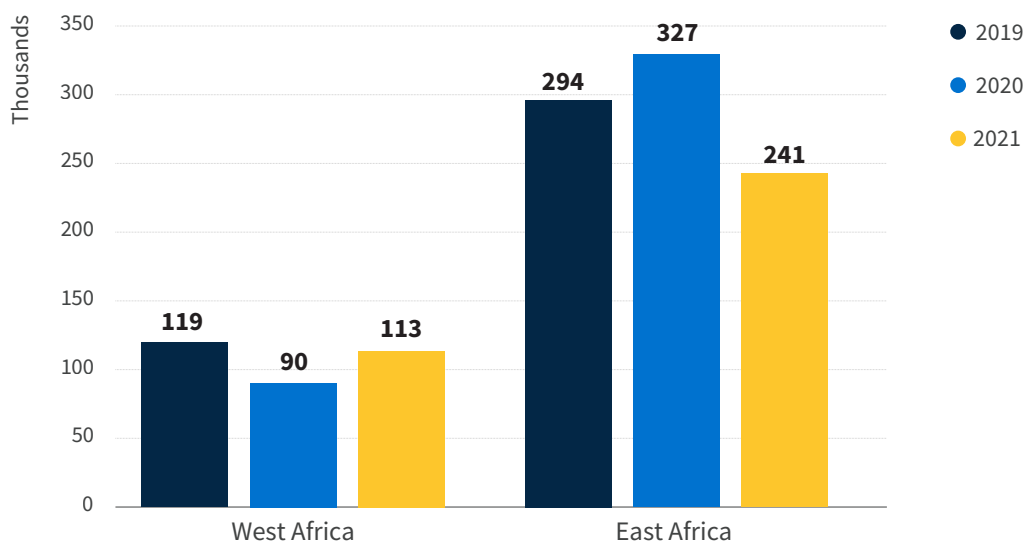

Cumulative sales from 2019 to 2021 show the five largest markets in descending order for TVs sold by affiliates are Kenya, the DRC, Tanzania, Côte d'Ivoire and Uganda. Kenya represents 47% of reported TVs sales globally between 2019 and 2021.⁷⁹

During the first half of the pandemic, increased TV sales were reported in East Africa (Figure 29). Evidence suggests lockdowns stoked demand for TVs across major markets for access to information and entertainment. However, pandemic-related supply chain disruptions particularly affected TV sales, raising prices and leading to stock-outs for distributors during the second half of 2020 and in 2021. TV sales in Kenya in particular increased by 27% in 2020 over 2019 before decreasing by 38% in 2021.

⁷⁷ Note: Affiliates data collection for off-grid appliances only began in 2018 and it is estimated that affiliate sales data in that year was significantly under-reported including in subsequent years; CLASP estimates less than 40% of affiliate companies reached out share their sales data.

⁷⁸ GOGLA analysis of data collected for the Global Off-Grid Solar Sales and Impact Reports 2016-2021.

⁷⁹ Ibid.

b. Fans

Most fan sales reported by affiliates are from specialized manufacturers. Among off-grid household appliances, fans are one of the most affordable appliances, typically recording low unit prices and high sales volumes. Fan sales are highly seasonal, with most sales happening between January and June in South Asia due to climate and weather.

South Asia is the largest market due to strong local manufacturing capability and overall large market size (Figure 30).^{80,81} Fans are sold for cash and are generally not bundled with a power source. Outside of South Asia, fan sales have grown in West and Central Africa, where fans are likely to be bundled with a SHS. Fans sold in kits are

generally table or pedestal fans and are smaller than those sold in South Asia, where ceiling fans are more common.

Since 2019, Pakistan, Bangladesh, India, the Philippines and Nigeria have consistently been among the largest markets for affiliate fan sales.⁸² In South Asia, sales have slowed since 2019. While participation by companies in data collection for fans in South Asia has been inconsistent. This makes confirming trends challenging, although anecdotal evidence points to COVID-19 restrictions and supply chain disruptions for raw materials - such as copper and aluminum - as factors that may have affected the market. Meanwhile, fan sales in West Africa have steadily increased over the last two years.

Figure 30: Affiliates sales volumes of Fans in South Asia and West Africa (2019-2021) (thousands)⁸³

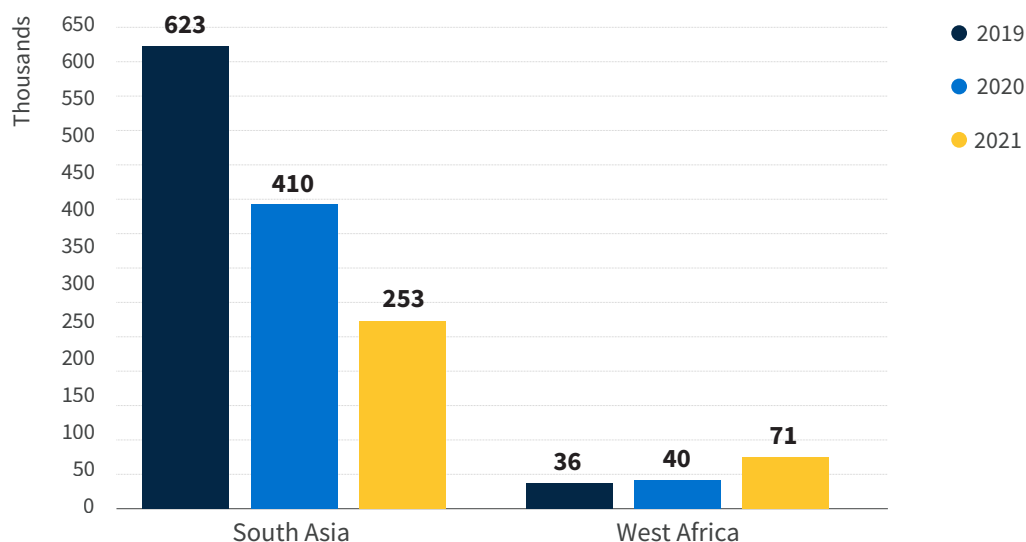

Affiliates reporting sales of RUs are mostly specialized manufacturers, although some SHS companies have also integrated RUs into their offerings. Refrigeration units include fridges, freezers and multi-temperature fridges.⁸⁴

The market for off-grid refrigeration solutions remains nascent. Barriers identified to the mainstreaming of this technology include a lack of proven commercial business models and high cost. The sales data available is limited⁸⁵, but shows decreasing sales in 2020 and 2021 (Figure 31).

This is tied to the effects of the pandemic, and key affiliate companies deprioritizing RUs within their portfolio.

80 [Efficiency for Access \(2021\), Fans Solar Appliance Technology Brief.](#)

81 [Efficiency for Access \(2021\), Appliance Data Trends.](#)

82 *GOGLA analysis of data collected for the Global Off-Grid Solar Sales and Impact Reports 2016-2021.*

83 *Ibid.*

84 *Larger walk-in or containerized RUs have so far not been included in the data collected from affiliates.*

85 *Participation of RU manufacturers in the data collection remains limited at this stage.*

Figure 31: Global affiliates sales volumes of refrigeration units (2019-2021)⁸⁶

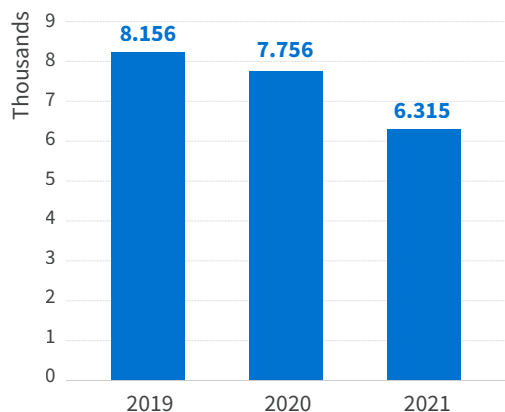

Similarly to RUs, affiliates reporting SWP sales are mostly specialized manufacturers. Reported sales volumes remain low at 13,000 units in 2021 (Figure 32).⁸⁷ Affiliates mainly report sales of SWPs in sub-Saharan Africa and a majority of units are reported as PAYGo sales. However, this is largely due to low participation in the data collection for this appliance category. Therefore, it is not representative of known large markets, particularly in South Asia where PAYGo is far less common.⁸⁸ A peak in sales in 2019 linked to government programs in South Asia limits the analysis of trends. Yet, growth in sales reported by affiliates in 2021 is an encouraging sign.

Figure 32: Global affiliates sales volumes of solar water pumps (2019-2021)⁸⁹

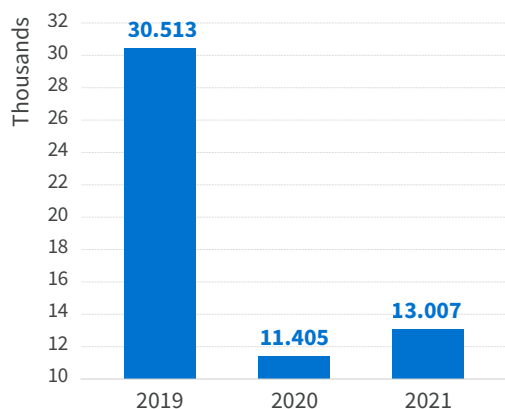

⁸⁶ GOGLA analysis of data collected for the Global Off-Grid Solar Sales and Impact Reports 2016-2021.

⁸⁷ Ibid.

⁸⁸ By design, the data collection is limited to SWP smaller than 3kW. Furthermore, at this stage, participation of manufacturers in the data collection remains limited.

⁸⁹ GOGLA analysis of data collected for the Global Off-Grid Solar Sales and Impact Reports 2016-2021.

⁹⁰ GOGLA (2022), Supply Chain Disruption Survey (unpublished).

⁹¹ Note: Pricing data comprises data from the Mangoo marketplace, company websites, consultations with off-grid companies and Chinese manufacturers, and industry reports such as the Ipsos market studies in Kenya, Ethiopia, and Tanzania.

2.4 Global OGS Product Pricing Trends

2.4.1 Global Solar Energy Kit Pricing Trends



Global supply chain disruptions due to COVID-19 have fueled increases in global nominal prices for solar energy kits. There is also increased price competition across the solar energy kits product range.

Material costs, logistics costs, and lead times have increased due to supply chain disruptions related to COVID-19. Prior to the COVID-19 pandemic, solar PV module prices steadily declined over decades, driven largely by technological advances in PV module efficiencies and associated hardware cost improvements. Since 2020, however, the cost of PV modules and key electrical components such as microcontroller chips has increased due to inflated prices of raw materials, chronic shortages of key components and shipping disruptions brought about by the pandemic.

Increased costs and resulting inflationary pressures from pandemic-related impacts have resulted in price increases for solar energy kits (Figures 33 and 34). Market data from surveys and stakeholder consultations indicate manufacturers have passed on cost increases to consumers across solar energy kit product categories.⁹⁰ For example, between 2020 and 2022, the median nominal prices of 0-1.5 Wp increased from \$8 to \$9, while the 3-10 Wp segment recorded an increase from \$88 to \$91 over the same period.⁹¹ The range of nominal prices for 3-10 Wp products widened to \$37-\$172 in 2022 compared to \$36-\$140 in 2020. The products at the high end of this range include new products with features similar to lowest-capacity SHS rated at 11-20 Wp.

Figure 33: Global indicative cash price ranges of solar lanterns and multi-light system products by wattage (2020 versus 2022)⁹²

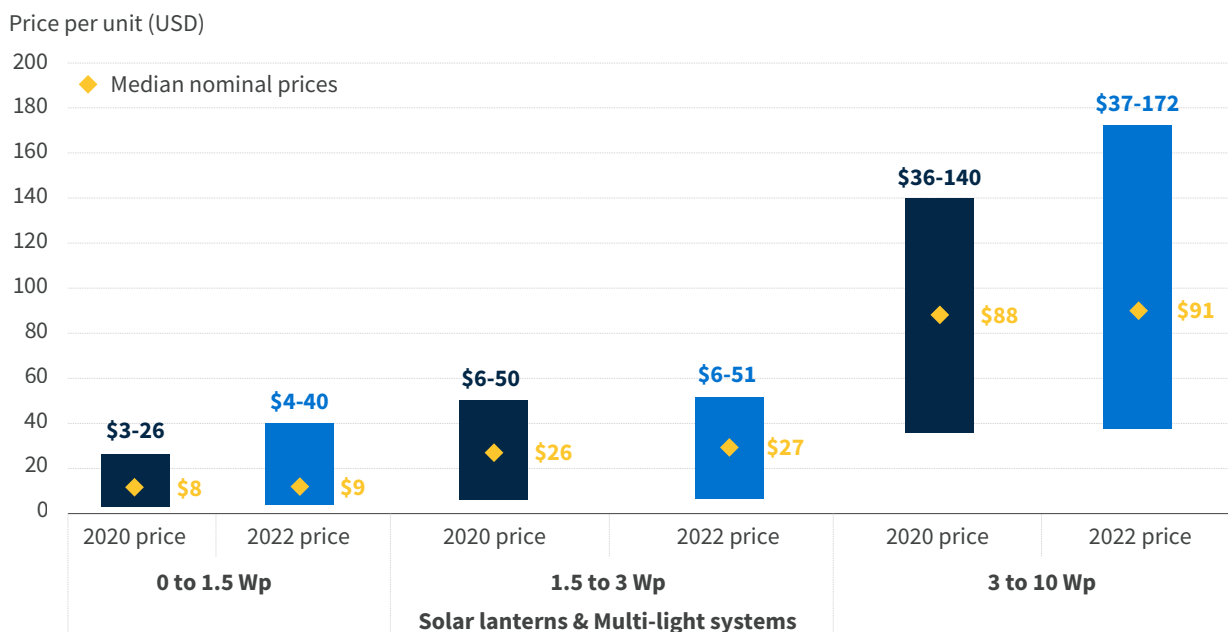

These prices are listed as nominal to indicate they are not adjusted for inflation. Based on our analysis of key inflation rates across key markets in sub-Saharan Africa and southeast Asia, we estimate an aggregate inflation rate of 6.58% which may have contributed to price increases between 2020 and 2022 in addition to the other factors outlined throughout the report.

Compared to 2020, while average nominal prices across solar home systems have increased, the range of nominal prices has also increased, signaling increased price competition as well as diversification by solar kit companies.⁹³ For instance, the range of nominal prices for 51–100 Wp SHS widened to \$50–\$1,100 in 2022 compared to \$168–\$892 in 2020, with both cheaper as well as more expensive products catering to more consumers within lower and higher price ranges.

Markets in East Africa and South Asia on average continue to see marginally lower price points than markets in West Africa and East Asia; certain key markets in West Africa, however, have also experienced sustained inflationary pressures contributing to higher prices.

East African markets are quite mature, with high levels of competition and greater access to manufacturing hubs, while markets in South Asia have shorter supply chains and higher availability of cheaper, non-affiliate products sourced directly from China. On the other hand, West

African markets are relatively smaller, with reduced market competition and have longer supply chains compared to East Africa, as evidenced by marginally higher \$38 median nominal prices for solar lanterns and multi-light system products in West Africa compared to \$36 in East Africa, respectively (Figure 35).⁹⁴

Note that West African markets have also experienced increased inflation at an estimated 15.5% compared to East Africa which has an inflation of 9.7% which has impacted the prices.⁹⁵ Despite the supply chain disruptions caused by the pandemic, delivery time to East Asia from China has remained short, with containers arriving in the Philippines within 7 days; however the last-mile logistics needed to deliver solar energy kits from main shipping ports to retail customers spread across multiple islands and a corresponding lower economies of scale results in higher overall costs to serve customers, thus higher retail prices in East Asia (median nominal solar lanterns and multi-light systems price: \$40) compared to

⁹² Note: The comparison of 2020 and 2022 prices is based on prices accessed from the sources above at the time of writing the report; it is likely that some of the 2022 pricing data includes 2020 prices as companies have not updated their databases and/or are unwilling to disclose latest prices.

⁹³ Open Capital Advisors analysis of data from Mangoo marketplace, company websites and consultations.

⁹⁴ Ibid.

⁹⁵ Note: Key countries in West Africa such as Nigeria and Ghana have experienced sustained inflationary pressures since the onset of the pandemic which could have had a larger impact on prices in that region compared to East Africa.

South Asia (median nominal solar lanterns and multi-light systems price: \$26) (Figure 35).⁹⁶ Notably, regional price trends for SHS mimic those of solar lanterns and multi-

light system products. For example, the median nominal prices for SHS products are on average 7% higher in West Africa than in East Africa.

Figure 34: Global indicative cash price ranges of SHS by wattage (2020 versus 2022)⁹⁷

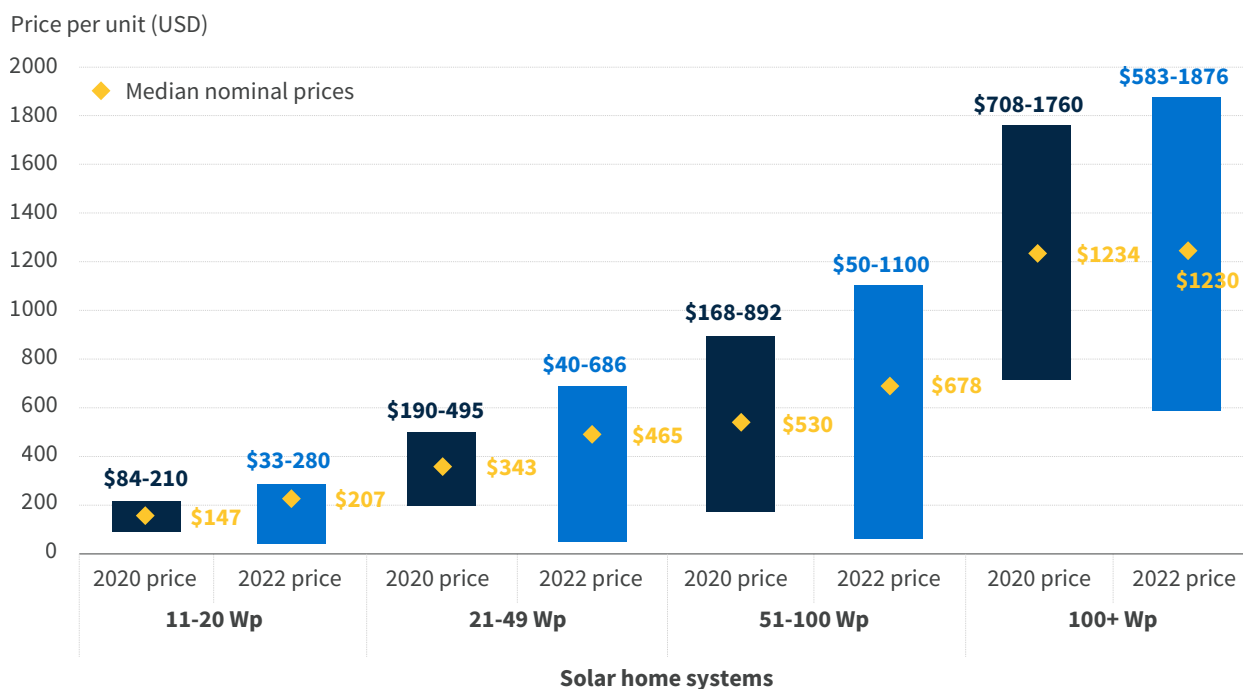

There is not sufficient data in East Asia to allow for comparison with South Asia.⁹⁸ Potential impact of policy interventions such as the revocation of OGS VAT exemptions by the Kenyan government in 2020 likely also contributed to consumer price increases in the country. Similarly, in West Africa while countries continue to introduce regulations to promote the off grid solar

space, the timing of individual country integration efforts with ECOWAS policies remains uncertain resulting in uncertainties in tax and duty exemptions which adds to the cost of doing business and corresponding impacts on product prices sold in that region. (See Chapter 7 for additional policy considerations).

⁹⁶ Open Capital Advisors analysis of data from Mangoo marketplace, company websites and consultations.
 Note: Some markets e.g. East Asia have significantly limited pricing data available online hence these prices are only indicative estimates; similarly across regions, pricing sample sizes varied significantly e.g. in West Africa we consistently had about a dozen pricing estimates per product category compared to East Africa where there are >50 pricing estimates for affiliate products.

⁹⁷ Note: Pricing data comprises data from the Mangoo marketplace, company websites, consultations with off-grid companies and Chinese manufacturers, and industry reports such as the Ipsos market studies in Kenya, Ethiopia, and Tanzania. The comparison of 2020 and 2022 prices is based on prices accessed from the sources above at the time of writing the report; it is likely that some of the 2022 pricing data includes 2020 prices as companies haven't updated their databases and/or are unwilling to share latest prices.

⁹⁸ Open Capital Advisors analysis of data from Mangoo marketplace, company websites and consultations.

Figure 35: Regional indicative cash price ranges of solar lanterns and multi-light system products⁹⁹

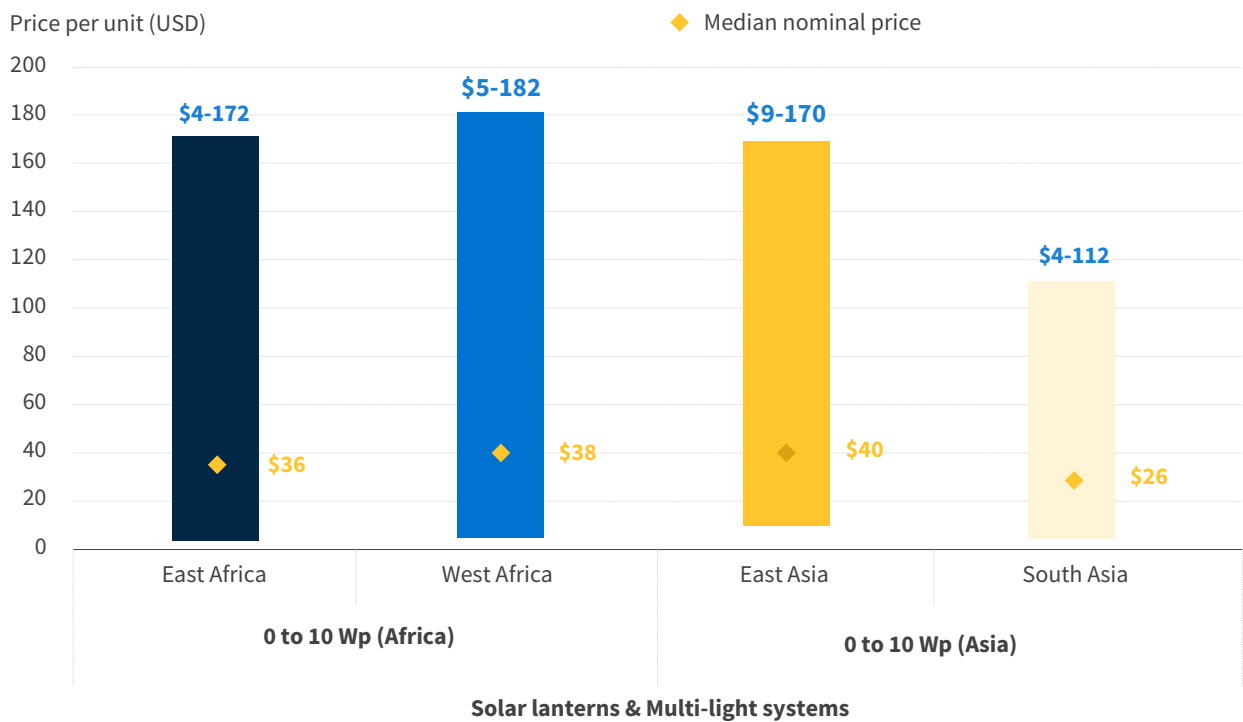

PAYGo financing continues to drive uptake of OGS sales by enabling increased affordability.

PAYGo adoption over the last several years has increased solar kit sales by lowering the upfront cost. PAYGo increases the affordability of products for customers, with down payments equaling on average approximately 8-9% of total asset price (Figure 36). Note that PAYGo down payments can range from 3% of total cost for solar lanterns and multi-light system products to 15% of total cost for higher-value SHS products. PAYGo is also increasingly offered for DC-powered appliances (particularly in sub-Saharan Africa) either as part of solar home systems or sold as standalone components, often leveraging income generated by productive assets to make repayments, those assets including TVs, hair clippers, and mobile charging stations.¹⁰⁰

PAYGo prices are on average 25–27% higher than cash over-the-counter prices for solar lanterns and multi-light systems and SHS in line with associated financing costs (Figure 36). Nonetheless, for low-income consumers, the increase in total cost is offset by two key benefits: (1) increased affordability of PAYGo systems, as it is easier to spend \$1 a day than pay \$250 upfront, and (2) the opportunity offered by PAYGo for previously unbanked and underbanked households to build a credit profile and lower future perceived credit risk. As a result of PAYGo payment history, many off-grid companies have leveraged customers' credit payment history to offer other products and services on credit, such as PUE appliances (See Section 2.4.2).¹⁰¹

⁹⁹ Open Capital Advisors analysis of data from Mangoo marketplace, company websites and consultations.

¹⁰⁰ *Ibid.*

¹⁰¹ Open Capital Advisors analysis and consultations.

Figure 36: Estimated PAYGo down payment of the total contract amount and average PAYGo price as a percentage of cash price for solar energy kit products¹⁰²

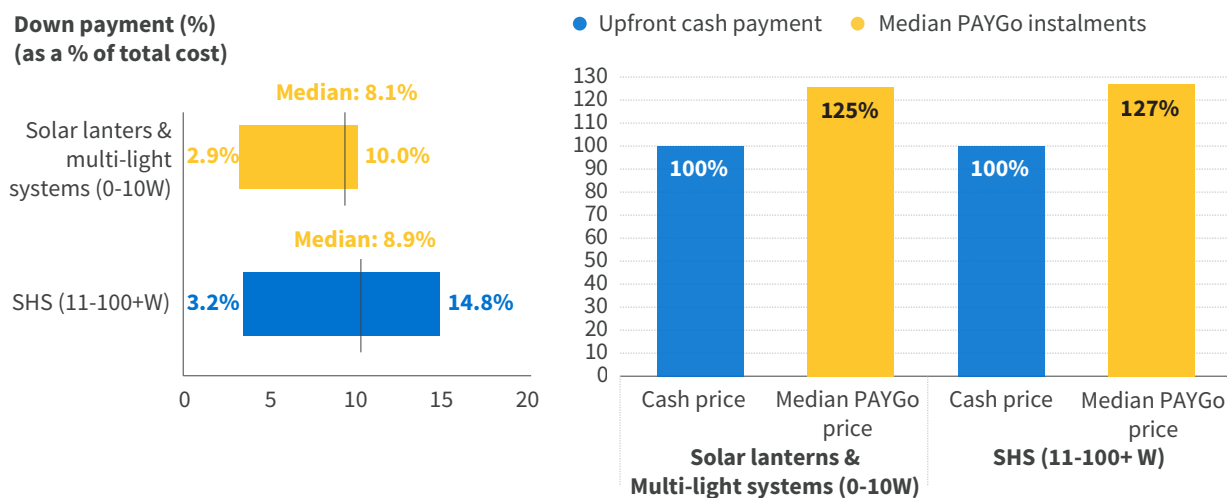

2.4.2 Global Appliance Pricing Trends

Pandemic-related lockdowns hampered transportation and logistics and subsequently increased component and shipping costs, leading to increased prices for appliances such as fans and TVs (Figure 37). According to a recent survey conducted with a relatively small number of manufacturers, over the last two years average consumer prices of appliances have increased by 13% for small TVs and 9% for fans.¹⁰³ These price increases have been driven by the increase in cost of electrical components such as microcontroller chips and batteries due to the supply chain disruptions caused by the COVID-19 pandemic which has led to manufacturers passing on these cost increases to consumers.¹⁰⁴ It is worth noting that TV prices increased during the early stages of the COVID-19 pandemic due to stockouts caused by increased demand (See Section 2.2) as well as supply chain disruptions.¹⁰⁵



Global price increases due to COVID-19 related supply chain disruptions have resulted in reduced PUE appliance sales, but companies are expected to continue innovating products focused on the agricultural sector.



¹⁰² Note: These charts reflect average PAYGo prices; actual PAYGo prices can occasionally range up to twice the comparable cash prices depending on company, product and other market factors.

¹⁰³ GOGLA (2022), Supply Chain Disruption Survey (unpublished) and Open Capital Advisors analysis and consultations. Note that these are unbundled prices i.e. TV sold as a standalone appliance instead of part of a solar home system kit; also there are no 2020 prices included given this data was not collected as part of developing the 2020 MTR.

¹⁰⁴ GOGLA (2022), Supply Chain Disruption Survey (unpublished).

¹⁰⁵ GOGLA (2022), Global Off-Grid Solar Market Report Semi-Annual Sales and Impact Data Report H2 2021.

Figure 37: Global indicative cash price ranges for solar TVs and fans¹⁰⁶

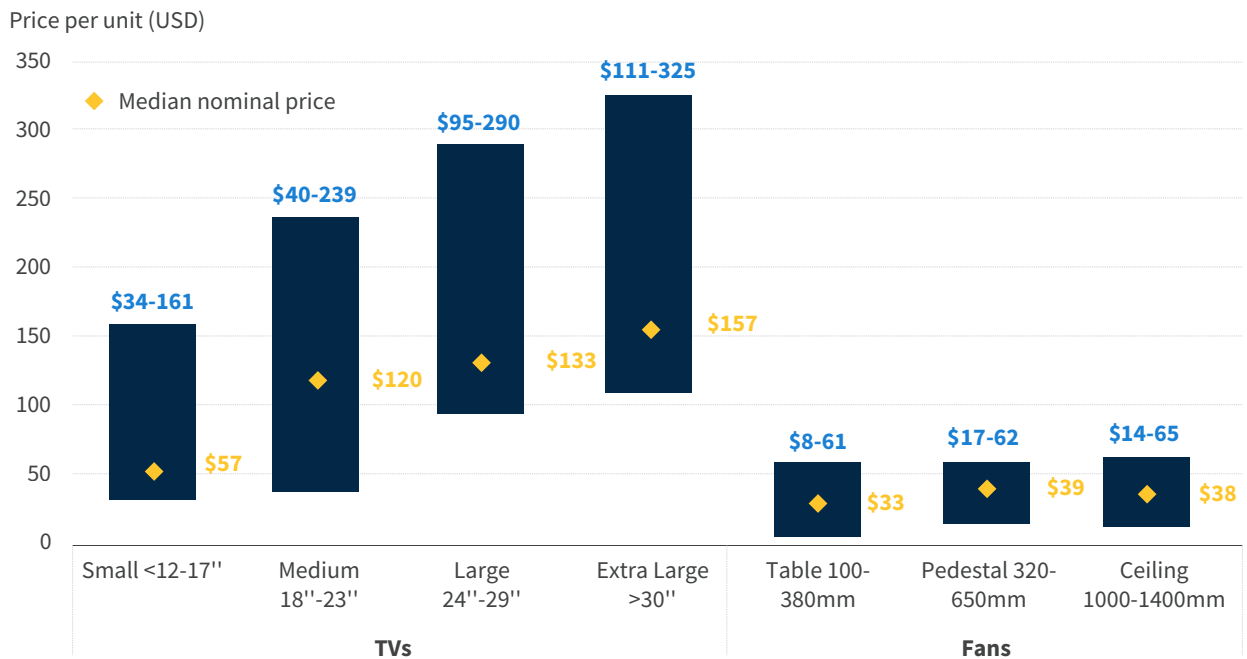

As with solar energy kits, PAYGo has made PUE appliances more affordable.¹⁰⁷ Total PAYGo prices for solar water pumps on average command a 29% mark-up over cash prices to cover financing costs (Figure 38), PAYGo products make these products more accessible.

Customers pay on average a 23% down payment, after which, the remaining balance can be paid in regular PAYGo installments over an 18-month period (or more), depending on the company, market and other customer or risk factors.¹⁰⁸

Figure 38: Estimated PAYGo down payment of the total contract amount for solar water pumps (left) and average PAYGo price as a percentage of cash price (right)¹⁰⁹

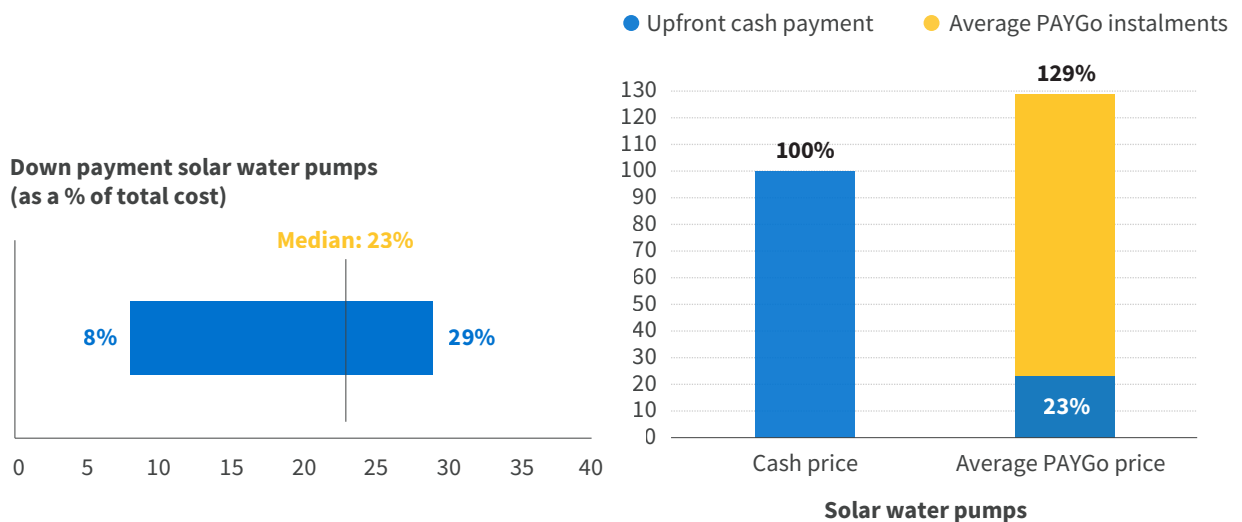

¹⁰⁶ Open Capital Advisors analysis of data from Mangoo marketplace, company websites and consultations.

¹⁰⁷ [GOGLA \(2020\), Global Off-Grid Solar Market Report Semi-Annual Sales and Impact Data H1 2020.](#)

¹⁰⁸ Open Capital Advisors analysis and consultations.

¹⁰⁹ Open Capital Advisors analysis of data from Mangoo marketplace, company websites and consultations.

Research and development in solar water pumps has led to cost reductions since 2019. However, disruptions caused by COVID-19 have increased the costs of some raw material components such as metal casings, as well as logistics costs.¹¹⁰ Companies recently introduced complete, easy-to-install solar water pumping kits to replace hand pumps in off-grid areas. Priced at an average \$400–500, a comparable price point to hand pumps, these kits last longer and require less maintenance. Higher-powered solar water pumps of 1,500+W, though, cost more than \$1,000 on average (Figure 39).¹¹¹

There are now more products for off-grid cold storage, with manufacturers developing new, niche cooling solutions offered at varying price points based on consumer needs. For example, India has one of the largest milk markets in the world, and manufacturers in the market have developed new solar-powered products in refrigeration and cold storage. Solar-powered milk chilling systems range from medium-sized 300L systems for smallholder farmers in villages to large-scale, 10,000L chilling systems for dairy corporations.¹¹²

Figure 39: Estimated global cash price ranges of PUE appliances¹¹³

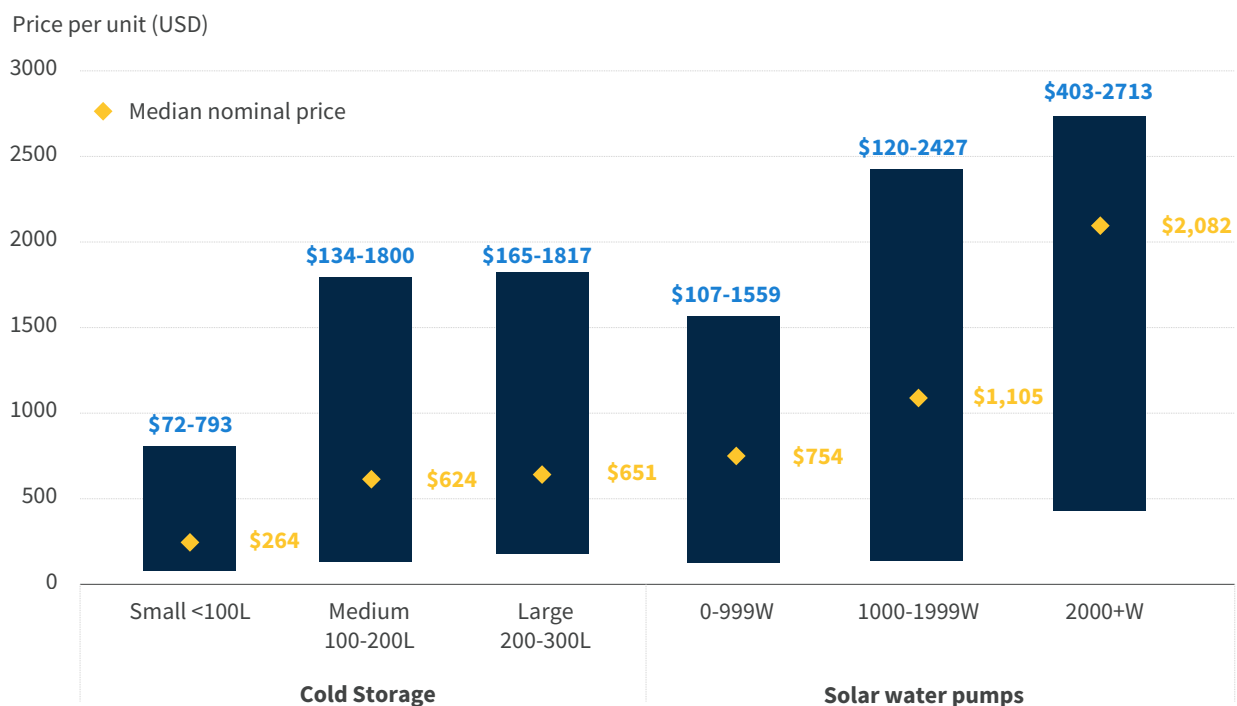

110 GOGLA (2022), Supply Chain Disruption Survey (unpublished) and Open Capital Advisors analysis and consultations.

111 Open Capital Advisors analysis and consultations.

112 Open Capital Advisors analysis and consultations.

113 Open Capital Advisors analysis of data from Mangoo marketplace, company websites and consultations.

№	Имя	Возраст	Пол	Состояние
1	Иванов Иван Иванович	45	М	Удовлетворительно
2	Петров Петр Петрович	32	М	Удовлетворительно
3	Сидоров Сергей Сергеевич	58	М	Удовлетворительно
4	Климов Владимир Владимирович	28	М	Удовлетворительно
5	Мухоморов Михаил Михайлович	65	М	Удовлетворительно
6	Попов Павел Павлович	40	М	Удовлетворительно
7	Смирнов Степан Степанович	35	М	Удовлетворительно
8	Тихонов Тимофей Тимофеевич	50	М	Удовлетворительно
9	Федотов Федор Федорович	38	М	Удовлетворительно
10	Харьков Харитон Харитонович	60	М	Удовлетворительно
11	Цыганов Цыган Цыганович	42	М	Удовлетворительно
12	Чайков Владимир Владимирович	30	М	Удовлетворительно
13	Шаров Сергей Сергеевич	55	М	Удовлетворительно
14	Щербинин Александр Александрович	48	М	Удовлетворительно
15	Юрьев Юрий Юрьевич	33	М	Удовлетворительно
16	Яковлев Яков Яковлевич	62	М	Удовлетворительно
17	Зайцев Зинаид Зинаидовна	47	Ж	Удовлетворительно
18	Кузнецова Елена Еленовна	36	Ж	Удовлетворительно
19	Леонова Ольга Ольговна	52	Ж	Удовлетворительно
20	Морозова Мария Мариновна	29	Ж	Удовлетворительно
21	Новикова Наталья Натальевна	67	Ж	Удовлетворительно
22	Овсянникова Оксана Оксановна	41	Ж	Удовлетворительно
23	Павлова Елена Еленовна	34	Ж	Удовлетворительно
24	Романова Татьяна Татьяновна	59	Ж	Удовлетворительно
25	Соловьева Светлана Светлановна	43	Ж	Удовлетворительно
26	Толстикова Татьяна Татьяновна	31	Ж	Удовлетворительно
27	Устинова Елена Еленовна	64	Ж	Удовлетворительно
28	Филиппова Елена Еленовна	46	Ж	Удовлетворительно
29	Харькина Елена Еленовна	37	Ж	Удовлетворительно
30	Цыганова Елена Еленовна	56	Ж	Удовлетворительно
31	Чайкина Елена Еленовна	27	Ж	Удовлетворительно
32	Шарова Елена Еленовна	61	Ж	Удовлетворительно
33	Щербинина Елена Еленовна	49	Ж	Удовлетворительно
34	Юрьева Елена Еленовна	39	Ж	Удовлетворительно
35	Яковлева Елена Еленовна	63	Ж	Удовлетворительно

№	Имя	Возраст	Пол	Состояние
36	Иванов Иван Иванович	45	М	Удовлетворительно
37	Петров Петр Петрович	32	М	Удовлетворительно
38	Сидоров Сергей Сергеевич	58	М	Удовлетворительно
39	Климов Владимир Владимирович	28	М	Удовлетворительно
40	Мухоморов Михаил Михайлович	65	М	Удовлетворительно
41	Попов Павел Павлович	40	М	Удовлетворительно
42	Смирнов Степан Степанович	35	М	Удовлетворительно
43	Тихонов Тимофей Тимофеевич	50	М	Удовлетворительно
44	Федотов Федор Федорович	38	М	Удовлетворительно
45	Харьков Харитон Харитонович	60	М	Удовлетворительно
46	Цыганов Цыган Цыганович	42	М	Удовлетворительно
47	Чайков Владимир Владимирович	30	М	Удовлетворительно
48	Шаров Сергей Сергеевич	55	М	Удовлетворительно
49	Щербинин Александр Александрович	48	М	Удовлетворительно
50	Юрьев Юрий Юрьевич	33	М	Удовлетворительно
51	Яковлев Яков Яковлевич	62	М	Удовлетворительно



A woman wearing a blue headwrap and a patterned shirt is talking on a mobile phone. She is sitting in a rustic, dimly lit environment, possibly a small shop or a community center. In the background, there are various items on a table, including a container labeled 'Mpishi PO'. The overall atmosphere is one of daily life in a rural or semi-rural setting.

03

**The Socioeconomic
and Environmental Impact
of the OGS Industry**

KEY MESSAGES

- The number of people accessing solar energy kits grew from 420 million people at the end of 2019 to 490 million people at the end of 2021
- An estimated 128 million people missed out on accessing off-grid solutions in the last two years
- Solar energy kits and productive use of energy products have already avoided 190 million tonnes of CO₂e and plays a critical role in achieving a faster and more equitable clean energy transition
- Today, the off-grid sector is powering over 10 million enterprises and creating hundreds of thousands of green jobs

3.1 The Impact of OGS on Energy Access

The number of customers with a Tier 1 or higher level of electricity access continued to rise (Figure 40), with those gaining Tier 2 access growing by 160% between 2019 and 2021.¹¹⁴ This is a result of ongoing sales, the

longer lifespan of larger products, and current customers beginning to move up the clean energy staircase.¹¹⁵ In many cases, customers move up the clean energy staircase when they have paid off, or made savings from, their initial solar energy kit (SEK) and are able to purchase new, often larger products or additional services. 3.8 million customers have also gained access to solar TVs in 2020 and 2021, which were particularly critical for accessing news, health information and educational programs during COVID-19 lockdowns.¹¹⁶

Figure 40: People benefiting from access to electricity through solar energy kits (millions)¹¹⁷

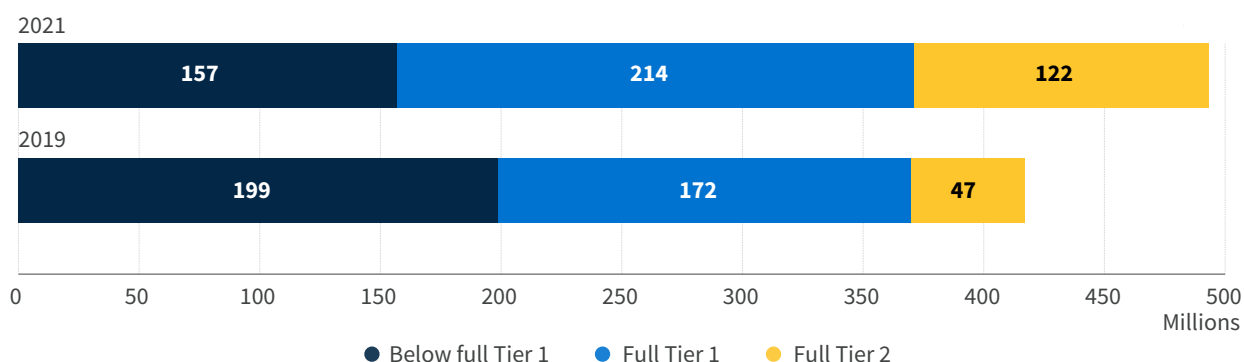

SEKs provide the primary source of lighting for millions of rural households and provide both backup and first-time access in urban centers (Figure 41). Households which rely on solar for their primary lighting are predominantly rural. However, there are also notable levels of urban sales, with numbers varying widely by country. Urban sales of solar energy kits are often assumed to provide grid-back up, yet the data shows that many urban households also use them for primary access.¹¹⁸ Amongst these, Uganda, Rwanda and Liberia, see SEKs more commonly used to provide urban households with first-time access than to provide backup power.¹¹⁹



The number of people accessing solar energy kits has grown from 420 million people in 2019 to over 490 million people at the end of 2021, with more people gaining higher 'Tier 2' levels of access.

¹¹⁴ GOGLA and Open Capital Advisors analysis, using the Off-Grid Solar Standardized Impact Metrics.

¹¹⁵ GOGLA consultations.

¹¹⁶ GOGLA and Open Capital Advisors analysis, using the Off-Grid Solar Standardized Impact Metrics.

¹¹⁷ Ibid.

¹¹⁸ World Bank/ESMAP analysis of the Multi-Tier Framework Country-level Surveys. For more information, please see <https://mtfenergyaccess.esmap.org>

¹¹⁹ Ibid.

Figure 41: Location of customers using solar kit as a primary source of light/power in 8 countries with high electricity access deficits¹²⁰

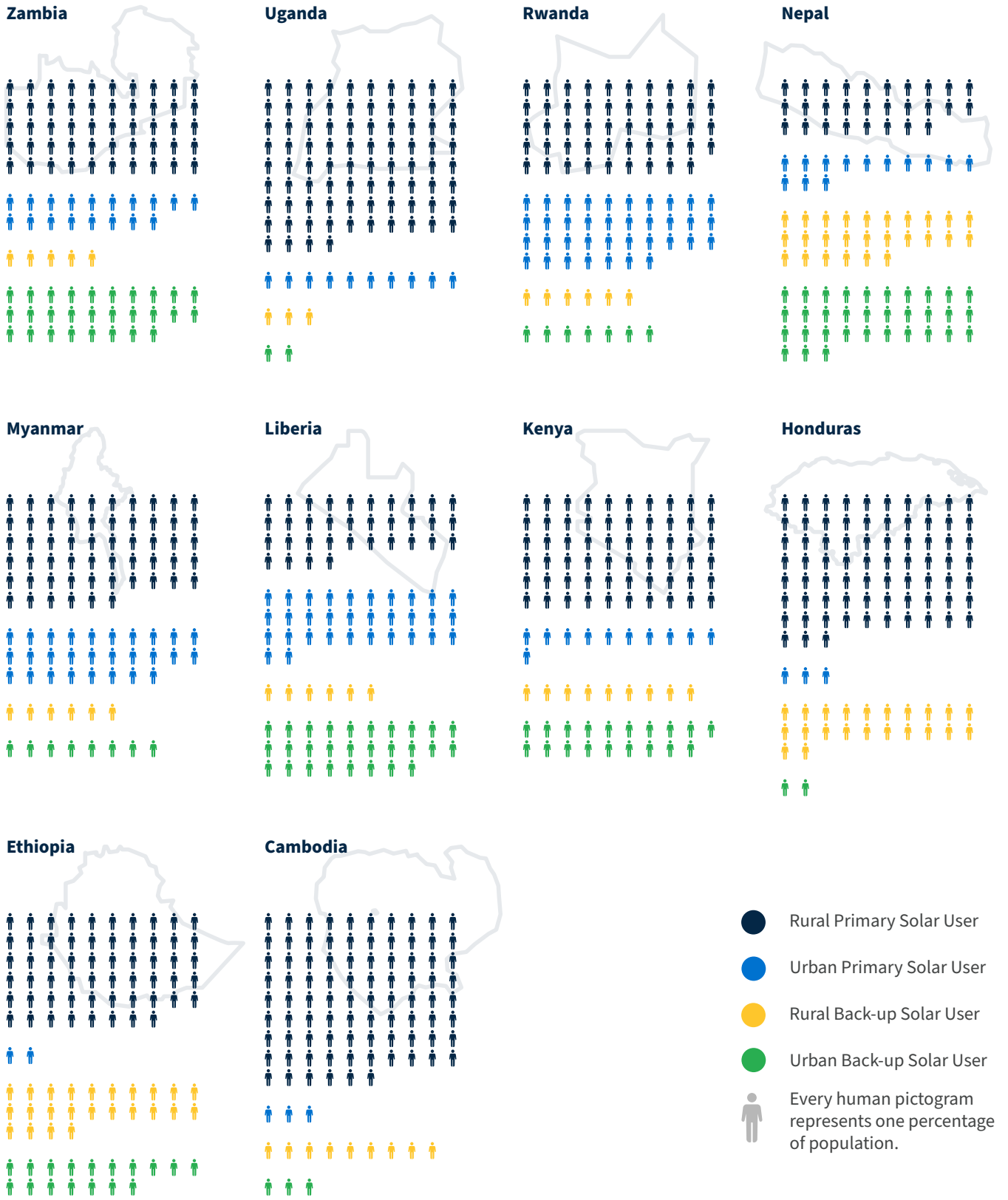

120 Ibid.



Households in the lowest income quintiles using solar energy kits most commonly use them as a primary source of light, rather than for grid back up.¹²¹ For example, of people using SEKs in Nepal, 90% of those in the lowest income quintile use their kit for a primary source of electricity and 10% use them as a backup source of power. In contrast, 30% of solar users in the top income quintile use SEKs as a primary electricity source and 70% as backup.¹²²

SEK customers in the lowest income quintile rely almost exclusively on solar lanterns, suggesting that affordability stops those in poorer households purchasing larger products, such as solar home systems. In Zambia, amongst households using solar energy kits in the lowest income quintile, only 4% own a solar home system, with 95% relying on solar lanterns and 1% using their product for grid backup. On the other hand, 86% of those in the top income quintile use SEKs as grid backup, 7% use solar home systems as a primary light source and 7% use solar lanterns.¹²³ This suggests that many low income customers cannot afford a SHS, and that more affordable solar lanterns are instead providing the first access they have to clean electricity. Consultations with companies reveal that, where customers do gain access to solar lanterns, these products can provide a step onto the clean energy staircase. Energy savings and/or a customer's emerging credit history from their solar lantern purchase can allow them to buy bigger systems and/or additional products.

121 *Ibid.*

122 *Ibid.*

123 *Ibid.*

Many customers with PAYGo off-grid solar are now accessing larger SHS, appliances and 'beyond energy' solutions. Off-grid customers are now buying additional DC appliances, solar generators that can power their current appliances with an AC-DC converter, or 'beyond energy' solutions such as mobile phones and clean cookstoves (see Section 5.4). It is most commonly solar energy kit companies that are expanding their ranges to enable their customers to buy additional, and often more expensive products. However, some companies selling larger PUE products are also expanding their range to increase their impact and meet demand. For example, solar irrigation company, SunCulture, now includes lighting and television as part of its latest solar irrigation bundle.



An estimated 128 million people missed out on accessing OGS solutions in the last two years.

A slow-down in sales growth compared to pre-pandemic levels caused an estimated 128 million people and 3.1 million businesses to miss out on access to solar energy kits in the last two years (Figure 42). This is a result of disruption to OGS company operations and supply chains. Millions more people were pushed into poverty, reducing their ability to afford OGS technologies.

Figure 42: Additional people with improved electricity access from off-grid solar kits, per year, alongside those who would have gained access had the sector remained on its pre-COVID growth trajectory¹²⁴

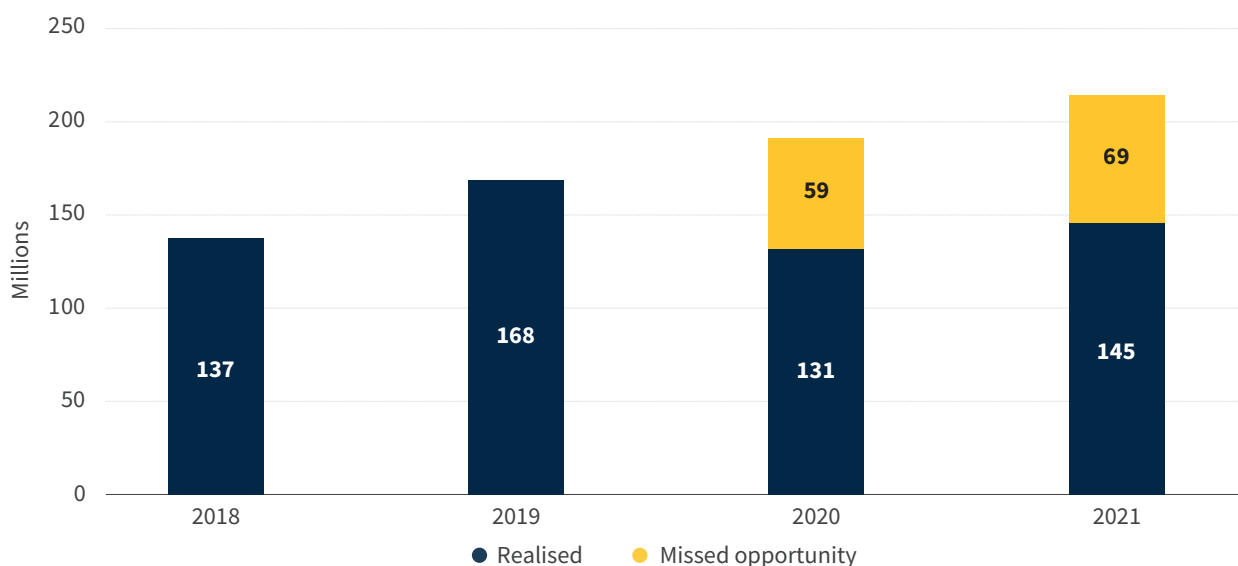

In addition to the missed opportunity for greater electricity access, data from the IEA revealed that the increase in poverty created by the pandemic also led to millions of people losing electricity access.¹²⁵ This was also seen in the OGS sector. Analysis on ‘write-off ratios’ for PAYGo companies suggests the number of households that may have lost access to their solar energy kit due to default on their payments doubled between 2019 and 2020, remaining at the higher rate in 2021.¹²⁶ Research to uncover the effects of COVID-19 on PAYGo customers showed that, while they continued to see significant value in their systems and tried to prioritize electricity payments, 75% reported increased economic hardship in May 2020, with 28% still finding their financial situation worse than pre-pandemic in October 2020, a key factor in the higher write off ratio.¹²⁷ Amongst other macroeconomic challenges, the high levels of global inflation and the looming food security crisis linked to the war in Ukraine continue to pose a risk to customer finances. Higher defaults leading to lost electricity access is a significant concern for customer wellbeing. Further insights on the growth in the write-off ratio and efforts to address this issue are discussed in Section 5.3.

The growth in the number of people displaced by war, violence, persecution and human rights abuses has also seen more people lose electricity access, with UNHCR estimating that the number of people displaced grew by 8% between 2020 and 2021 to almost 90 million.¹²⁸ The vast majority of refugees and internally displaced people lack access to electricity. Those who can purchase energy do so at disproportionate cost.^{129,130} Forced to leave their communities, without electricity, they struggle to gain basic power to study, work, or stay connected to their families. In the last few years, off-grid companies have continued to provide solar energy kits to several areas of humanitarian crisis, including Yemen and Bangladesh¹³¹, and delivered market-based projects in Kenya, Rwanda and Uganda.¹³² However, the Global Platform for Action on Sustainable Energy in Displacement Settings, has recognized that extensive funding, program and capacity gaps need to be addressed in order to electrify the millions of refugees and internally displaced people living without modern energy.

¹²⁴ [GOGLA and Open Capital Advisors analysis, using the Off-Grid Solar Standardized Impact Metrics.](#)

¹²⁵ [IEA \(2022\), Tracking SDG7: The Energy Progress Report 2022.](#)

¹²⁶ [GOGLA \(2020\), PAYGo COVID Impact Monitor.](#)

¹²⁷ [60 Decibels \(2020\), COVID-19 Dashboard.](#)

¹²⁸ [UNHCR \(2022\), Global Trends: Forced Displacement 2021.](#)

¹²⁹ [GPA \(2022\), The State of the Humanitarian Energy Sector: Challenges, Progress and Issues in 2022.](#)

¹³⁰ [Moving Energy Initiative \(2018\), Prices, Products and Priorities: Meeting Refugees Energy Needs in Burkina Faso and Kenya.](#)

¹³¹ [GOGLA analysis of data collected for the Global Off-Grid Solar Sales and Impact Reports 2019-2021.](#)

¹³² [EnDev \(2020\), Humanitarian Energy: Energy for Micro-enterprises in Displacement Settings.](#)

3.2 The Impact of OGS on the Sustainable Development Goals (SDGs)



In addition to SDG7 - access to affordable, reliable, sustainable and modern energy - the OGS sector is demonstrating benefits that will help achieve a further 10 SDGs, with PUE significantly expanding impacts related to SDG8 and SDG13.

Solar kits and efficient appliances create a ripple effect of positive impacts, beyond access to electricity. The graphic below shows how the OGS sector is positively affecting various SDGs (Figure 43), whilst the sections below take a deep dive into impact areas in which new data or activity has emerged in the last two years. These include health, employment, food security, and climate.



© Power Africa

Figure 43: Examples of how OGS contributes to the SDGs



GOAL 1: Low income households have saved an estimated \$26 billion in traditional fuel costs through a switch to solar lanterns and small SHS.¹³³



GOAL 2: 96% of farmers across six countries report an increase in productivity since using their off-grid solar water pump (SWP)¹³⁴, while cold storage is reducing food loss.¹³⁵



GOAL 3: 95% of SHS customers reported improved health and safety due to their system¹³⁶ and OGS technologies are also being used to power public institutions and health facilities.¹³⁷



GOAL 4: In West Africa 91% of households with children report that they have more time to do their homework thanks to solar energy kits¹³⁸ and OGS is being used to electrify schools.¹³⁹

¹³³ *GOGLA and Open Capital Advisors analysis, using the Off-Grid Solar Standardized Impact Metrics.*

¹³⁴ *Efficiency for Access Coalition and 60 Decibels (2021), Uses and Impact of Solar Water Pumps.*

¹³⁵ *International Food Policy Research Institute (2019), Solar-powered Cold-storages and Sustainable Food System Transformation: Evidence from Horticulture Markets Interventions in Northeast Nigeria.*

¹³⁶ *GOGLA (2021), Powering Opportunity: Energising Work, Enterprise and Quality of Life with Off-Grid Solar.*

¹³⁷ See Section 3.2.1.

¹³⁸ *GOGLA (2021), Powering Opportunity: Energising Work, Enterprise and Quality of Life with Off-Grid Solar.*

¹³⁹ *UN Foundation and SEforALL (2019), Lasting impact - Sustainable Off-grid Solar Delivery Models to Power Health and Education.*



GOAL 5: SWPs reduce domestic hardship for women. Without a local irrigation source, 14 million women in sub-Saharan Africa spend more than 30 minutes a day collecting water.¹⁴⁰



GOAL 6: Thousands of SWPs are used to provide fresh, clean water, with emerging technologies also using solar to remove salt and arsenic from water sources.^{141,142}



GOAL 7: 490 million people are currently benefiting from improved electricity access, thanks to off-grid solar.



GOAL 8: 370,000 FTE jobs have been created in the off-grid industry; and an estimated 10 million enterprises are currently powered by OGS solutions.^{143,144}



GOAL 9: Millions of people can stay better connected via phone, radio, TV and the internet, with 9 million people more financially included via PAYGo solutions.¹⁴⁵



GOAL 10: 28% of SHS customers in East Africa, many of whom live on less than \$3.10 a day, reported that their system had helped them increase their income, helping reduce inequality.¹⁴⁶



GOAL 13: 190 million metric tons of CO2e has been avoided by replacing kerosene and diesel generators, while OGS is improving resilience to climate change and natural disaster.^{147,148}



© Oolu Solar

140 [UNICEF \(2016\). Collecting Water is often a Colossal Waste of Time for Women and Girls.](#)

141 [OffGrid Web \(2018\), Offgridbox Solar Water Purification System.](#)

142 [Otter et al. \(2017\), Arsenic Removal from Groundwater by Solar Driven Inline-Electrolytic Induced Co-Precipitation and Filtration-A Long Term Field Test Conducted in West Bengal.](#)

143 [GOGLA \(2019\), Off-Grid Solar: A Growth Engine for Jobs.](#)

144 [GOGLA and Open Capital Advisors analysis, using the Off-Grid Solar Standardized Impact Metrics.](#)

145 [GOGLA analysis.](#)

146 [GOGLA \(2021\), Powering Opportunity: Energising Work, Enterprise and Quality of Life with Off-Grid Solar.](#)

147 [GOGLA and Open Capital Advisors analysis, using the Off-Grid Solar Standardized Impact Metrics](#)

148 See Section 3.2.2.

3.2.1 Powering Healthcare



Since the start of the pandemic, the urgency of electrifying health centers and storing vaccines has become more acute.

Many governments and development agencies created COVID-19 emergency response activities in respect of off-grid cooling and power for health infrastructure.

About 1 billion people worldwide are served by healthcare facilities without reliable electricity.¹⁴⁹ It is estimated that one in four healthcare facilities in sub-Saharan Africa has no electricity.¹⁵⁰ Approximately, 28% have reliable access to electricity.¹⁵¹ A number of governments and development organizations worked to address this challenge and improve health infrastructure and vaccine storage with off-grid solutions. For example, at least 30 countries, including Sao Tome and Principe, Nigeria, Togo, Somalia, Indonesia, Kyrgyzstan have procured, or are procuring, cold chain equipment such as solar direct drive refrigerators using funds from Gavi, the World Bank, and other agencies as a part of their COVID-19 response (see Box 2).¹⁵² The success of the initiative in Sao Tome and Principe has led to additional funding from ESMAP and the Green Climate Fund to enhance the country's climate-

friendly cold chain infrastructure and illustrates a shift to the use of decentralized clean energy to power health infrastructure in areas the grid does not reach, or where there is inconsistent power supply.

At least 25 countries, including Uganda, Haiti, Ethiopia, Burundi and Liberia, funded by the World Bank are also planning to power health centers with off-grid solar. These projects are currently under preparation or implementation. Increased programmatic focus on the use of OGS to electrify health infrastructure is also noted in Section 7.3.

As well as powering healthcare, off-grid solar technologies have a range of other health benefits. For example, solar water pumps are improving crop yields and clean water supplies that have a direct impact on nutrition and reduced risk of water borne viruses (see Section 3.2.2). Reduced kerosene use in the home, by replacing traditional lanterns with solar lighting, leads to significant reductions in particulate matter which has been linked to reduced risk of respiratory and pulmonary disease. Results from studies in Kenya¹⁵³ and Uganda¹⁵⁴ reveal that replacing all household kerosene and candle light with solar lanterns also reduced exposure to particulate matter (PM2.5) by 37%-50% among women, even when solid fuels continued to be used for cooking. School children, who do not perform household cooking tasks, experienced even greater exposure reductions of 73%.

Box 2: The solar direct drive (SDD) refrigerator: A game-changer for vaccine storage

The emergence of the SDD refrigerator has proved transformative for vaccine storage over the last decade. Since 2017, Gavi has delivered more than 15,300 SDD fridges to 36 African countries, including nearly 3,400 units to the DRC and 5,400 to Nigeria. Meanwhile, the Head of the organization's Health Systems and Immunisations Strengthening team credited the off-grid equipment for achieving a 25% jump in child vaccination rates in Africa between 2010 and 2020.

SDD fridges do not require batteries. They run solar energy through an isolator and store it directly in the body of the refrigerator. This helps to minimize cost and complexity and expand product lifetime. Further insights on SDD refrigerator innovations are in Section 6.3.

149 [World Health Organization \(2022\), Accelerating Access to Electricity in Health-care Facilities.](#)

150 *Ibid.*

151 *Ibid.*

152 *World Bank/ESMAP analysis.*

153 [Lam et al. \(2018\), Exposure Reductions Associated with Introduction of Solar Lamps to Kerosene Lamp-using Households in Busia County, Kenya.](#)

154 [Wallach et al. \(2022\), Effect of a Solar Lighting Intervention on Fuel-based Lighting use and Exposure to Household Air Pollution in Rural Uganda: A Randomized Controlled Trial.](#)

3.2.2 OGS, Food Security and the Ukraine Crisis



Events in Ukraine in 2022 have put a spotlight on food security and the potential of solar irrigation and cooling to enhance food production and storage.

In 2021, the UN reported 53 countries were officially in a global food crisis, with 570,000 people in four countries in a food ‘catastrophe’ phase. The Ukraine crisis has pushed the price of food to a historical high due to reduced food supply and rising energy costs.¹⁵⁵ The UN World Food Programme estimates that, as the war continues, the number of people in acute hunger is projected to increase by 17% to 323 million people, with the steepest rises in sub-Saharan Africa.¹⁵⁶

Today, 14% of food is lost unintentionally between harvest and distribution¹⁵⁷, while vast areas of arable land go without the benefits of irrigation. For example, the area equipped for irrigation in Africa is currently only 6%.¹⁵⁸ Improved irrigation on the continent could lead to increased crop rotations and yields that improve agricultural productivity by at least 50%.¹⁵⁹ In this context, solar irrigation and cooling technologies have become increasingly recognized for their potential to improve food security, whilst reducing reliance on external energy sources.¹⁶⁰

Solar irrigation and cooling systems are increasing crop yields and preserving produce. In respect to irrigation, this can be seen in a study of nearly 1,200 customers across Kenya, Rwanda, Senegal, Tanzania, Uganda and Zambia which found that 96% of SWP customers saw an increase in farm productivity, and 90% reported higher earnings.¹⁶¹

Off-grid solar cooling technologies, meanwhile, are beginning to play an important role in food storage. This is illustrated by India-based Promethean Power Systems which has reached over 75,000 farmers with refrigerators for dairy and other food products.¹⁶²

Some off-grid companies are also working to enhance the impact of their products by supporting their customers with auxiliary services, such as connecting farmers with agronomic advice and services.¹⁶³ While solar irrigation and cooling markets are still emerging, the technologies show strong potential and are also seen as a key resource for rural communities as they adapt to a warming climate (see Section 3.2.3).

3.2.3 OGS and Climate Change: Mitigation, Adaptation and Resilience



Solar energy kits and productive use of energy products have reduced 190 million tonnes of CO₂e and are playing a key role in a faster and more just clean energy transition.

Off-grid solar products can benefit hundreds of millions of climate-vulnerable people that live without electricity.¹⁶⁴ Despite the high burden these individuals will face as a result of climate change, they are least responsible. OGS provides fast and affordable basic electricity access from clean energy sources while rapidly reducing CO₂e and building the adaptive capacity and resilience of climate-vulnerable people.

In terms of mitigation, replacing kerosene lanterns with solar lighting has already avoided an estimated 190 million tonnes of CO₂e, equivalent to taking 51 coal-fired

¹⁵⁵ [World Food Programme \(2022\), Global Report on Food Crises 2022.](#)

¹⁵⁶ [United States Institute of Peace \(2022\), The Ukraine War is Deepening Global Food Insecurity - What Can Be Done?](#)

¹⁵⁷ [Efficiency for Access Coalition \(2021\), Creating a More Resilient Food System Through Sustainable Refrigeration.](#)

¹⁵⁸ [IFPRI \(2010\), What is the Irrigation Potential for Africa?](#)

¹⁵⁹ [IFPRI \(2020\), Irrigation to Transform Agriculture and Food Systems in Africa South of the Sahara.](#)

¹⁶⁰ [GOGLA consultations.](#)

¹⁶¹ [Efficiency for Access Coalition and 60 Decibels \(2021\), Uses and Impact of Solar Water Pumps.](#)

¹⁶² [Efficiency for Access Coalition \(2021\), Creating a More Resilient Food System Through Sustainable Refrigeration.](#)

¹⁶³ [GOGLA consultations.](#)

¹⁶⁴ [IEA \(2020\), Power Systems in Transition: Challenges and Opportunities Ahead for Electricity Security.](#)

power plants offline for a year^{165,166} while replacing diesel generators also has clear emissions reduction benefits. Recent research conservatively estimates that generators used to provide grid backup emit more than 100 megatons of CO₂ every year.¹⁶⁷

In sub-Saharan Africa, replacing generators with solar alternatives avoids as much CO₂ as 20% of the region's vehicles being replaced with clean alternatives.¹⁶⁸ These figures exclude the emissions that could be reduced by avoiding the use of direct drive equipment such as diesel-powered water pumps and agricultural machinery, which would provide further emissions reduction benefits. For example, emissions avoided as a result of replacing diesel powered water pumps with solar show that, even at an early stage of their deployment, the technology has already saved an estimated 640,000 tonnes of CO₂e,¹⁶⁹ equal to taking 138,000 cars off the road.¹⁷⁰

While the industry has not yet developed a standard framework to fully capture and monitor its contribution to climate adaptation and resilience, there is increasing recognition of the role that OGS can play. Off-grid systems enable people, businesses and communities to absorb and recover from climate shocks and help them to adjust to and anticipate changes. OGS provide positive adaptation opportunities in terms of green jobs and solar-powered enterprise (as highlighted in Section 3.2.4), increase the availability of water and food as climate change increases insecurity (as noted in Section 3.2.2) and create clean energy communications infrastructure. They also boost resilience by creating savings and new revenue streams, strengthening energy systems and enhancing health and health infrastructure (see Section 3.2.1).

Figure 44: Key impacts of OGS on climate adaptation and resilience

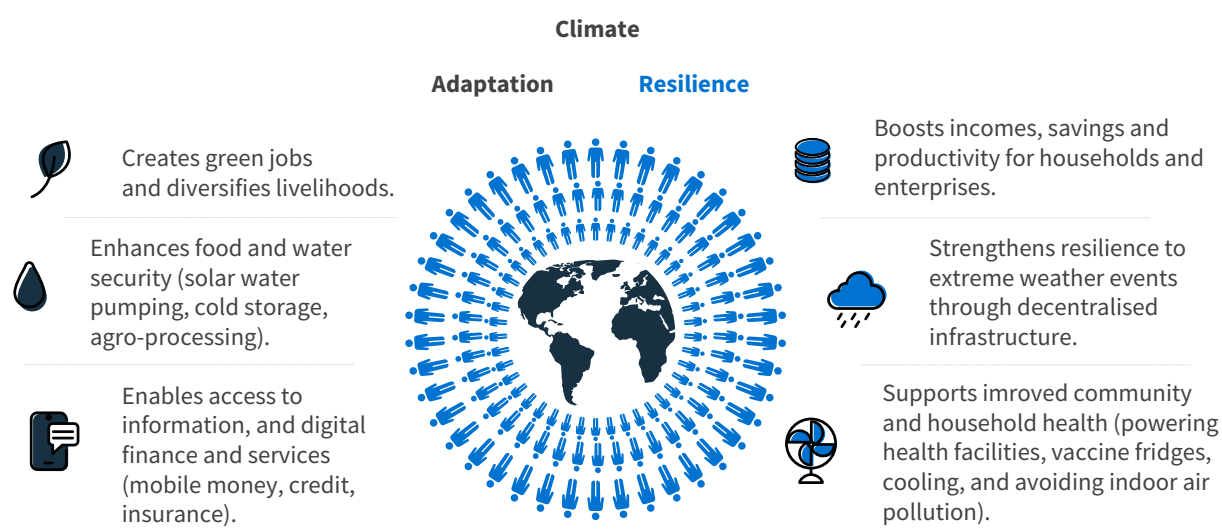

165 GOGLA and Open Capital Advisors analysis, using the Off-Grid Solar Standardized Impact Metrics.

166 United States Environmental Protection Agency (2022), [Greenhouse Gas Equivalencies Calculator](#).

167 International Finance Corporation (2019), [The Dirty Footprint of the Broken Grid](#).

168 Ibid.

169 GOGLA and Open Capital Advisors analysis, using the Off-Grid Solar Standardized Impact Metrics.

170 United States Environmental Protection Agency (2022), [Greenhouse Gas Equivalencies Calculator](#).

As with food security, water insecurity will be exacerbated by climate change, and where solar technologies can play a critical role. The use of solar pumps in Kutupalong refugee camp in Bangladesh, home to nearly one million refugees provides an example, where solar powered pumps pull chlorinated water from tanks keeping it safe from contaminants.¹⁷¹ Solar innovations are also being used to remove life-threatening levels of salt and arsenic from drinking water, a challenge that will be heightened as water supplies are overused and depleted.^{172,173}

Solar energy kits are improving connectivity by enhancing charging capacity for millions of homes and businesses, with many off-grid companies also selling solar powered radios, TVs, smartphones, tablets and ICT products. This is creating new renewable communications infrastructure, whilst helping communities gain the information needed to respond to negative climate impacts. Solar TVs, radios and tablets are enabling millions of people to access news and information, while access to smartphones are increasing access to digital advisory tools. For example, to build up climate resilient agriculture, the 'Ama Krushi' tool provides farmers in India with agronomic advice on up to 24 different crops through an interactive voice response hotline and SMS.¹⁷⁴

The growing suite of weather-related products, especially relevant for farming communities, also includes early warning system tools to help prevent weather-related disasters.¹⁷⁵ Whilst SMS early warning systems are also being used to alert communities in the face of natural disaster. The decentralized nature of OGS products, which continue to work when grid infrastructure has been compromised by strong winds, heat stress or flooding, also increase resiliency in the energy system and their ability to be rapidly deployed also make them well suited to use in disaster response, as was seen after the 2019 flooding in Mozambique.^{176,177}

Resilience is also boosted through improvements to household and community health as a result of OGS.

Increased use of solar fans provides a key example. Climate change is expected to drive global temperatures above 1.5 degrees centigrade which will heat tropical regions to levels that are at the limits of hospitable temperatures, with heatwaves already becoming more common and more intense. The recent heatwave in India and Pakistan between March and June 2022 saw temperatures of over 40 degrees for multiple consecutive days and reach highs of over 50 degrees.

As well as the potential to cause loss of life, high temperatures also destroy crops and reduce productivity.

The Chilling Prospects report estimates that in 2020, nearly 300 billion hours of work were already lost to heat stress.¹⁷⁸ A ceiling or table fan is typically the first active space-cooling solution accessed by poor populations that have only Tier 1 electricity access. A study on the use of highly efficient DC fans in Bangladesh also revealed that 81% of users reported a reduction in the number of mosquitoes in their home. The number of mosquitoes and other carriers of vector-borne disease are expected to rise with the warming climate.¹⁷⁹

Amongst other benefits, OGS products help to unlock savings or to increase incomes, further improving household ability to withstand shocks. Solar lanterns or multi-light kits are often bought outright or paid off within a few months, enabling families to save the money that would otherwise be used for consumable kerosene, candles or torch batteries.¹⁸⁰ Many SEK and appliance owners are also using them to generate additional income or to increase productivity, as explored further in Section 3.2.4.

171 [UNHCR \(2020\), Clean Energy, Clean Water: How Solar Power Brings Safe Water to Refugee Camps.](#)

172 [Water World \(2020\), Solar-powered Desalination System Provides WaterKiosk in Africa with Clean Water.](#)

173 [Otter et al. \(2017\), Arsenic Removal from Groundwater by Solar Driven Inline-Electrolytic Induced Co-Precipitation and Filtration-A Long Term Field Test Conducted in West Bengal.](#)

174 [GSMA \(2021\), COVID-19: Accelerating the use of Digital Agriculture.](#)

175 *Ibid.*

176 [GSMA \(2019\), The Weather Data Gap: How can Mobile Technology make Smallholder Farmers Climate Resilient?](#)

177 [GOGLA \(2019\), The role of Solar Lights and Solar Home Systems in Modern Day Disaster Relief.](#)

178 [Sustainable Energy for All \(2022\), Chilling Prospect Report.](#)

179 [Efficiency for Access Coalition \(2019\), The Socio-economic Impact of Super-efficient Off-grid Fans in Bangladesh.](#)

180 [SolarAid \(2015\), Impact Report.](#)

3.2.4 Clean Energy Jobs, Enterprise and Income Generation



The off-grid solar sector is powering over 10 million micro and small enterprises and creating hundreds of thousands of clean energy jobs directly within the industry.^{181,182}

Off-grid solar kits and PUE are already powering over 10 million micro and small enterprises. OGS has the potential to support hundreds of millions of MSMEs and smallholder farmers.¹⁸³ Real time energy use tracking in Nigeria reveals that, at their current rate of energy consumption, over 50% of MSMEs could be serviced by an off-grid solar system of 300Wp or below.¹⁸⁴ Several technologies designed specifically for productive use are also now available. For example, solar irrigation systems are now used on an estimated 190,000 farms¹⁸⁵, with data revealing that they have the potential to increase crop yields threefold for farms that are currently rain-fed. This is boosting income for rural communities and is expected to have a positive impact on employment.¹⁸⁶ Meanwhile, 80% of solar refrigerator customers in India reported using them for micro-enterprise, with a majority seeing income increases of over \$55 per month.¹⁸⁷

While COVID-19 led to some job losses in the OGS industry between 2020 and 2021, the sector additionally creates hundreds of thousands of direct jobs, many

in rural regions where employment opportunities are limited.¹⁸⁸ The industry supported an estimated 370,000 jobs in 2019, primarily in the supply, distribution and servicing of products.¹⁸⁹ COVID-19 led to some OGS industry job losses, with *Power for All's* latest job census revealing that employment in OGS dropped by 3% and 27% in Kenya and India respectively between 2020 and 2021.¹⁹⁰ However, the return to sales growth is already recovering.¹⁹¹ 55% of jobs created directly within the OGS industry are located in rural areas, with many undertaken by young adults, helping to boost incomes in regions which often have fewer opportunities and create employment for a growing youth population.¹⁹²

Women in the OGS workforce have a similar representation to country norms and, on average, make up a slightly higher proportion of the workforce than in other energy industries such as oil and gas.¹⁹³ However, there is still more work to do to achieve gender balance. Many companies and development actors are focused on increasing the number of women in the OGS workforce and increasing the number of women in positions of authority. For example, after recognizing that women in their workforce are underrepresented in management positions, PAYGo distributor, PEG Africa developed and implemented a Gender Action Plan, increasing female representation in leadership by 14% in twelve months.¹⁹⁴ While last-mile distributor, Yellow, found that few women were applying for sales agents roles in Malawi, so designated four female agents as “Project Khumbo Ambassadors” within their agent scout program to provide ongoing support to participating young women and girls, improved the inclusivity of job advertisements and provided digital skills training to women. This led to a jump from 11 women recruited in 2019 to 94 in 2020.¹⁹⁵

181 *GOGLA and Open Capital Advisors analysis, using the Off-Grid Solar Standardized Impact Metrics.*

182 [GOGLA \(2019\) Off-Grid Solar: A Growth Engine for Change.](#)

183 *Ibid.*

184 [A2EI \(2020\), Data Release #2.](#)

185 *GOGLA and Open Capital Advisors analysis, using the Off-Grid Solar Standardized Impact Metrics.*

186 [Efficiency for Access Coalition and 60 Decibels \(2021\), Uses and Impact of Solar Water Pumps.](#)

187 [CLASP \(2020\), Solar-Powered Refrigerators on the Frontlines of Off-Grid COVID-19 Response.](#)

188 [GOGLA \(2019\) Off-Grid Solar: A Growth Engine for Jobs.](#)

189 *Power for All (2022), Powering Jobs Census 2021 (forthcoming).*

190 *Ibid.*

191 *Ibid.*

192 [GOGLA \(2019\), Off-Grid Solar: A Growth Engine for Jobs.](#)

193 *Ibid.*

194 [PEG Africa \(2019\), Promoting Gender Equality in the Off-grid Energy Sector through Gender Inclusive Business Practices: A Case Study of PEG Africa.](#)

195 [Global Distributors Collective \(2021\), Gender in Business: Lessons Learned for LMDs.](#)



04

Customer Profiles and Engagement Strategies

KEY MESSAGES

- The majority of off-grid customers are still rural, low-income households. However, interest in off-grid solar amongst urban customers is growing and productive use of energy products are specifically meeting the needs of farmers and/or micro, small & medium enterprises
- While companies still predominantly use ‘traditional’ marketing approaches, as the sector grows, partnerships, data-led and digital methods are expected to grow and evolve
- Increased awareness of off-grid technologies has also led to more marketing via partnerships. These are playing a key role in the sale of agricultural products and service

4.1 The Off-Grid Solar Customer



The majority of off-grid customers are still rural, low-income households. However, interest in OGS amongst urban customers is growing and PUE products are specifically meeting the needs of farmers and/or MSMEs.

The majority of off-grid solar customers are rural households and micro-enterprises, due to the clear need for OGS technologies by an unelectrified customer base unlikely to benefit from alternative electricity sources in the near to medium term.¹⁹⁶ Solar energy kit (SEK) customers are predominantly rural, male and living under the median poverty line of \$3.10 (Figure 47).¹⁹⁷

There is a correlation between income levels and the size of solar energy kit that a customer is able to purchase. The lowest income customers tend to buy smaller off-grid products such as lanterns (see Section 3.1). Many customers are now making additional or repeat purchases from OGS companies, gaining access to an expanded range of products and services (see Box 3).¹⁹⁸

Many urban customers are also using solar energy kits to gain first time access to electricity. For example, 80% of urban SEK customers in Uganda are using their product as a primary energy source, illustrating that, although smaller, the unelectrified urban population is an important consumer group, and that OGS has a role to play in achieving universal access to electricity in urban centers.

OGS technologies are being used as a back-up to the grid or as a replacement for diesel generators, predominantly in urban settings. Many urban customers are also using SEKs to provide grid back-up or to replace diesel generators.¹⁹⁹ Urban customers are more likely to have consistent, salaried incomes, making them more likely to buy larger products and services, at a lower cost of customer acquisition and are less likely to default on their payment plan. While these customers are still a much smaller number than their rural counterparts, further data collection is needed to explore how the rural/urban customer split will develop in the coming years, and to understand if this will have a positive or negative impact on the pace of first-time access to modern electricity and on company sustainability and growth (see Section 5.4). Many urban customers have further recognized the potential of the PAYGo business model to enable them to purchase products such as TVs and smartphones on financing plans, particularly in sub-Saharan Africa where the PAYGo model is more prevalent.

Greater focus on weak grid areas has also led to increasing interest in off-grid technologies by urban MSMEs, with some companies expanding their product ranges to include larger commercial size solutions. Solar home systems are already used to support micro-enterprises in rural areas, with 21% of rural SHS customers in East Africa reporting that they use their system to

¹⁹⁶ World Bank/ESMAP analysis of the Multi-Tier Framework Country-level Surveys. For more information, please see <https://mtfenergyaccess.esmap.org>

¹⁹⁷ GOGLA (2021), *Powering Opportunity: Energising Work, Enterprise and Quality of Life with Off-Grid Solar*.

¹⁹⁸ GOGLA consultations.

¹⁹⁹ World Bank/ESMAP analysis of the Multi-Tier Framework Country-level Surveys. For more information, please see <https://mtfenergyaccess.esmap.org>

support a business.²⁰⁰ However, companies report that larger enterprises are increasingly looking at bigger SHS and solar generators that can power their current appliances and technologies using an AC-DC converter. For example, ZOLA Electric and A2EI are now selling solar generators (see Section 6.4). Targeting larger, and more expensive, products such as solar refrigerators at MSMEs, where the cost can be recouped through increased sales or the replacement of diesel generators, also helps ensure commercial viability.

Urban trends may grow due to urbanization and urban population growth. Rapid urbanization is taking place across major OGS markets. For example, African cities are expected to become home to a further 950 million people by 2050.²⁰¹ While the urban population in southeast Asia is expected to grow from 280 million people in 2017 to 373 million people in 2030.²⁰²

Amongst rural communities, farmers are increasingly aware of the potential of solar PUE technologies, and in particular solar irrigation. The number of off-grid distributors selling solar water pumps grew from 5% in 2019 to 26% in 2022 to meet the latent demand.²⁰³ However, income levels for many smallholder farmers remain low, and industry experts highlight affordability as a significant barrier to greater uptake.^{204,205} This suggests that, while OGS distributors and other industry stakeholders are seeing significant potential and interest in these technologies, getting the price point and/or repayment plan right for a rural smallholder audience will be more challenging. SWP costs range from \$400 - \$1000 (see Section 2.4).



Customers want to buy ‘follow on’ or ‘add on’ products. Yet affordability issues mean that demand is not always translated into additional purchases. However, PAYGo financing appears to be helping to bridge the gap.

Surveys of SHS customers reveal that nearly all customers want to purchase additional, related products, with the most common being TVs in the East and West African markets and fans in the South Asian market²⁰⁶, while more than a third of TV customers would like to buy a SWP (Figure 45).²⁰⁷ In practice, willingness/ability to pay is complex to ascertain, as customer decisions whether or not to buy a new product are affected by a range of factors including need, trust in the technology, affordability and the availability of alternatives. For example, research by A2EI on the potential of agri- milling technologies reveals that while solar mills may be cost-competitive with diesel, there is a high upfront cost of the system (\$1000) and potential risks in terms of inputs for repayments, such as competition for milling services in densely populated areas, and lower hours of operation anticipated in less densely populated areas (see Section 5.4).²⁰⁸

PAYGo financing appears to be enabling some customers to buy appliances alongside solar energy systems and/or to help them move up the clean energy staircase. 89% of solar TV customers in East Africa are buying these sold with an SHS²⁰⁹, whilst several PAYGo companies have reported that their current customers are buying new products and services (see Section 4.2).²¹⁰ More work to ascertain the cost benefits of products and explore ways to make them more affordable (e.g. via public funding mechanisms and/or the monetisation of impacts) are needed to unlock a wider customer base for all technologies, but particularly to expand PUE markets and reach poorer households with solar energy kits.

200 [GOGLA \(2021\), Powering Opportunity: Energising Work, Enterprise and Quality of Life with Off-Grid Solar.](#)

201 [OECD \(2020\), Africa's Urbanization Dynamics 2020.](#)

202 [Bloomberg \(2017\), Does Urbanization Drive Southeast Asia's Development?](#)

203 [Global Distributors Collective \(2022\), State of the Sector.](#)

204 *60 Decibels bespoke analysis for the Efficiency for Access Coalition.*

205 *GOGLA consultations.*

206 [GOGLA \(2021\), Powering Opportunity: Energising Work, Enterprise and Quality of Life with Off-Grid Solar.](#)

207 [60 Decibels and Efficiency for Access Coalition \(2020\), Use and Impact of Solar TVs.](#)

208 [A2EI \(2020\), Productive Use Report.](#)

209 [60 Decibels and Efficiency for Access Coalition \(2020\), Use and Impact of Solar TVs.](#)

210 *GOGLA consultations.*

Figure 45: SHS customers' top five most wanted appliances and features, per region²¹¹

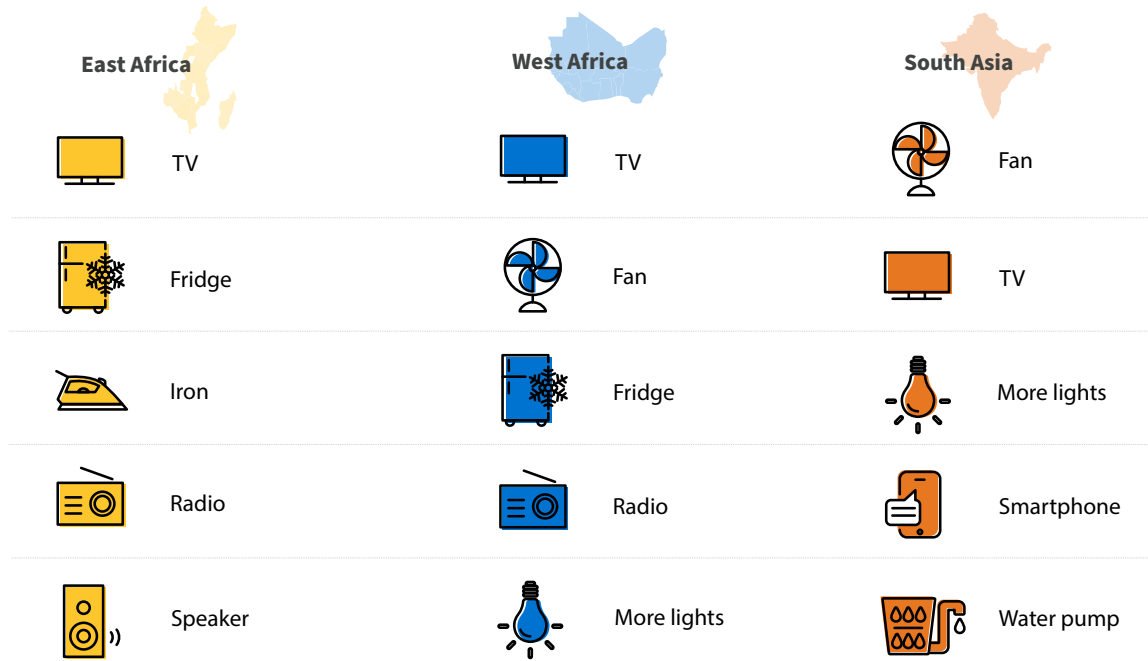

4.2 Customer Segmentation and Targeting



Customer targeting is still largely dependent on geography and local knowledge. However, companies are beginning to develop more sophisticated approaches to customer segmentation.

Companies report that customer segmentation is still commonly informed by geography, with businesses using local knowledge about population density, income levels, harvest times, key industries and other factors to define which products to sell, when and how. For example, as noted in Section 4.1, lower income customers may initially only be able to buy smaller energy kits, while specific needs and interests of customers in different geographies have a significant impact on product choice, as is the case of greater fan sales in South Asia where temperatures are warmer. PUE technologies, meanwhile, may have very

specific audiences. To grow its solar cooling business in Nigeria, Koolboks particularly targeted its outreach on fishing communities where the better storage of fish, a high value commodity, would lead to robust returns for customers. Companies commonly use desktop research to understand the broad characteristics of a new market, including the enabling environment, then spend time physically in the region to learn more at firsthand, before trying and testing products to explore which are the best sellers. However, as many companies are beginning to serve a wider range of off-grid customers with a broader suite of products and services, they are also beginning to segment them using more sophisticated data and tools (described below) and the development of customer profiles and personas.²¹²

A key growing segment for companies is their current customer base, due to both the increase in available data, and as a result of lockdowns which slowed their ability to reach new customers, accelerating the trend for cross-selling. This is particularly true for PAYGo companies that already have ongoing interactions with their customers as part of their business model. By tracking device usage and the stage of repayment plans, companies can learn the best moment to make offers of product upgrades or trade-ins to customers, the price points at which their current customers are likely to be able to purchase products or services, and the types of products that might

²¹¹ GOGLA (2021), *Powering Opportunity: Energising Work, Enterprise and Quality of Life with Off-Grid Solar*.

²¹² GOGLA consultations.

suit the energy usage of particular homes or businesses. As well as helping to determine the customers most likely to make repeat sales, this data can also be used to ensure that customers who have struggled to pay for products previously are not offered a new product they may not be able to afford. It can also serve as a basis to make more informed decisions about new customers, as those who have similar income streams, or are located in the same region may share common traits.

While some larger companies have built this data capacity in house, service providers such as Angaza, Solaris, Upya and K-Pay are providing software that can help other companies capture and monitor customer and new prospect data (see Section 5.4). Research by the Global Distributors Collective found that the two most common areas in which their member companies used third-party digital platforms in 2021 were for market and consumer research and payment collection, and mobile money integration.²¹³

Box 3: Easy Solar: A marketing journey

Established in 2016, Easy Solar is a distribution company based in Sierra Leone and Liberia which offers a range of high-quality products on PAYGo finance, including solar lanterns, solar home systems, appliances and cookstoves.

With a vision of affordable and accessible electricity for all, the organization initially focused on the sale of PAYGo enabled solar lanterns and home systems in rural settings, but its range and capacity has since grown. An early actor in the Sierra Leone off-grid space, the organization built its brand image and designed its marketing around targeted 'below-the-line' approaches, including door-to-door sales, community demos and promotional market days, as well as 'above-the-line' radio campaigns. In the early stages of the market, the cost benefit and durability narrative was key to the company's sales success, but as its brand presence grew, so did trust in the technology and organization, helping to streamline sales.

Today, most of its customers are still rural, off-grid households, but the company has also expanded to sell appliances, cookstoves and commercial-scale solar solutions, extending its customer base to urban customers, businesses and institutional buyers.

To aid its marketing strategy, the organization has developed several customer personas, including:

- **Graduates** - current customers who want bigger energy solutions and appliances
- **Band-aids** - customers used to grid-level power, who want a more reliable service
- **All or nothings** - customers who want kW-size power
- **Benefactors** - customers who buy solar solutions for their communities, families or friends

Personas are also used to guide marketing to businesses, such as:

- **Pop-ups** - tea houses, restaurants, etc. who want plug and play (PnP) solutions
- **Bricks and Mortar** - schools, offices, hospitals, etc. who want commercial-scale power
- **Farmers** - current customers who want solar irrigation and cooling

Though direct, word-of-mouth marketing remains crucial, to reach urban audiences, the organization additionally uses digital strategies, brand ambassadors, billboards/walls and key partnerships. For example, it has partnered with banks and civil service organizations to enable customers to buy their products directly through a payroll scheme, while its e-commerce platform caters to tech-savvy customers as well as the diaspora.

The organization has also explored other marketing techniques, including TV advertisements, news and awards. While it may use these again in the future, maintaining a trusted brand, an experienced sales team and strong customer relationship remain the company's key engagement priorities.

New digital innovations, such as geospatial mapping and agricultural simulators, are also contributing to customer targeting. Companies are also using third-party geospatial data as they develop their customer targeting, to uncover

where they may want to direct their operations both within specific countries and when they are looking to expand to new regions. For example, Fraym uses geospatial data such as density and access to infrastructure at a one kilometer

²¹³ [Global Distributors Collective \(2022\), State of the Sector.](#)

squared granularity, alongside national census and demographic data, as inputs to advanced machine learning algorithms. These are then used to help determine a region's potential customer base, and help companies plan their customer expansion strategies.

Big data innovations are also being explored in respect to solar water pumps, where low availability and the high cost of business data have been recognized as key constraints to reaching and serving customers. A recent pilot has used satellite imagery and agricultural simulators to model the growth of plants based on a parametrization of soil, weather, farming practices and available assets. The simulations are designed to quantify the potential impact of changes in farming practice, including use of solar irrigation alongside different farming techniques and inputs (eg. fertilizers, seeds etc). As well as providing a better understanding of SWP potential, customer impact and business opportunity, the data is designed for use in identifying where subsidies for SWPs would be most effective in raising farm incomes and finding areas most vulnerable to climate change and natural disasters.²¹⁴

Mobile data coverage datasets also help to determine where mobile-enabled PAYGo OGS transactions can be made. For example, the GSMA has developed mobile coverage maps that show the availability of mobile technologies in several countries in sub-Saharan Africa that help companies explore where customers will be able to get 2G, 3G or 4G mobile coverage, alongside other key infrastructure inputs such as primary and secondary roads and proximity to the central grid. The maps cover several nascent OGS markets, such as DRC, Guinea, Niger and South Sudan.²¹⁵

Alongside greater insights on the location and profile of potential customers, manufacturers advise that there is still a need for new business-to-business (B2B) connections, to bring their products to new markets via a locally knowledgeable partner. While big data can help unlock some business critical insights, a lack of information on the local distribution networks in nascent and emerging markets is cited as a challenge for expansion into these regions. As these countries are often affected by fragility, conflict or violence (FCV), establishing independent operations is also more difficult for vertically integrated players. Most have adopted a dual-strategy of providing both B2B and business-to-customer (B2C) services, enabling them to build out their own customer base in predominantly larger or more stable markets, whilst gaining a footprint in smaller or more complex ones. Companies selling solar water pumps have also advised that better connections with local agri-retailers are key for uptake of solar-powered agricultural equipment, as these

organizations already have a targeted customer-base to tap into (see Section 4.3).

4.3 Marketing and Customer Acquisition



Brand building remains a cornerstone of customer acquisition. Companies in nascent markets need to build awareness of OGS in general as part of their brand building efforts, while those with already trusted brands in more mature markets can more easily engage new customers.

When exploring the role of marketing in customer acquisition, companies advised that a first focus is always on building brand image and trust. After determining the audience type the company will focus on (rural, urban, MSME, etc.) and relevant product offering, this is usually done via the use of a vibrant - and locally relevant - brand name, company colors and logo. These are used for sales team uniforms and to brand company vehicles, shops and points of sale.

In nascent and emerging markets, and with newer technologies such as solar irrigation and cooling, companies need to build awareness of OGS products themselves as well as to establish their own identity. In contrast, in more mature markets, companies with trusted brands are able to fast-track sales as they do not need to build trust in their products in the same way. However, customers in mature markets are also increasingly shrewd in their deliberations between different brands and the product sizes, functions and promotions they offer.

A few companies have reported that some PAYGo customers are now buying more than one PAYGo package, a trend that could complicate companies' financial planning if it develops. Customers in more mature markets may also be more aware of the durability and reliability of non-quality assured products, and have a better sense of which ones may still provide value for money²¹⁶, as well as move from a company that is not providing quality products or good customer care.

²¹⁴ [Efficiency for Access Coalition \(2019\), Using Technology to Build Affordable Business Intelligence for the SWP Market.](#)

²¹⁵ [GSMA \(2022\), Mobile Coverage Maps.](#)

²¹⁶ [VeraSol \(2021\), Quality in the Off-Grid Solar Market: An Assessment of the Consumer Experience in Kenya.](#)

Figure 46: Common OGS marketing channels amongst affiliate B2C companies

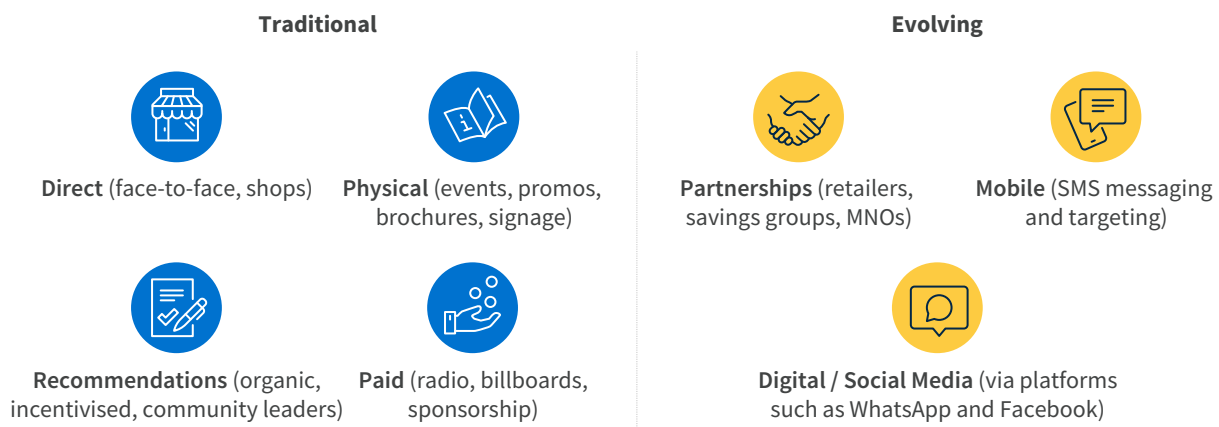

While companies still predominantly use traditional marketing approaches, as the sector grows, data-led and digital methods are expected to grow and evolve.

OGS customers in rural regions often have limited access to mass media channels, and are most commonly reached by traditional marketing strategies (Figure 46). Given the predominantly rural customer base, companies

have built marketing approaches that focus on creating one-to-one or community awareness, which generate trust in both off-grid solutions and their brand. These include door-to-door sales, demonstration days in local markets, and using local networks to encourage product adoption. For example, the most common way that customers hear about SWPs is via a recommendation from friends or family (Figure 46).²¹⁷ Marketing tools include, showcasing products, sharing flyers, creating promotions and sharing give-aways at events or through competitions. Some companies also support word-of-mouth marketing with customer incentive schemes, providing them with a benefit if they refer a friend, neighbor or family member.



217 *Efficiency for Access Coalition and 60 Decibels (2021), Uses and Impact of Solar Water Pumps.*

Figure 47: The rural OGS customer²¹⁸



Demographics

- Age: 36
- Gender: Male
- Family Status: Married with 3 children
- Location: Rural

Occupation

- Farmer

Education

- Primary

Purchasing behavior

- Learns about new products through recommendations
- Learns about new products in local market
- Learns about new products via advertisements on walls/branded vehicles
- Buys in local market
- Makes non-daily purchasing decisions with his wife

Willingness / Ability to Pay

- Lives on under \$3.20 per day
- Some limited savings
- Seasonal fluctuation in income, in line with harvest time

Goals

- For his children to grow up in a home with light and power
- To increase his income
- To own more appliances e.g. TV

Pain points

- Expense of kerosene, his current lighting source
- Danger of open flames and low levels of illumination
- Phone battery runs out / expensive to charge
- Time taken to travel to buy fuel and charge phone

Owned devices

- Mobile phone (basic)

Marketing strategies

- Traditional face-to-face approach
- Following PAYGo purchase, analyze payment history and recommend new purchases via SMS
- Seasonal offers and promos in line with harvest

Though limited due to company budget constraints, more traditional above-the-line (ABL) approaches, designed to reach a mass market are also pursued, including radio, press media and TV campaigns. Nevertheless, several companies report using these channels either for key launches and big announcements, or opportunistically. Companies may plan ABL outreach as a part of a major campaign, engage press when they have a key announcement or use national debate and programs to profile their products and services. For example, when d.light opened its customer care center in Nairobi in October 2020, it also took the opportunity to share an announcement on its financial support for customers struggling with loan payments due to COVID-19.²¹⁹ Whilst PUE companies, meanwhile, have collaborated with the East African agricultural TV Show, Shamba Shape, to profile the potential for solar water pumps to improve livelihoods.²²⁰

More data on electricity usage, payment patterns, payment history and loan completion status is being effectively applied to mobile marketing, in particular through SMS messaging. SMS is being used by a number of companies to alert customers of new offers, promotions and product availability at relevant times within the customer lifetime cycle, as well as to coincide with peak

sales times such as harvest times, festivals and holidays. Digital efforts are often supported by calls from company call centers. While companies are largely using their own databases or customer profiles to share new purchasing opportunities, the latest Lighting Asia program also used 'local area messaging' to alert potential customers about the campaign and to share promotions (see Box 5).

Efforts to reach more 'tech savvy' urban customers (Figure 48), as well as to reduce the cost of reaching better connected rural audiences, have led to a growing focus on engagement through digital media strategies, applications and platforms. For example, customers may be reached by WhatsApp and Facebook and then directed to make an e-commerce purchase, either through a company's own web platform, or that of an online distribution partner or aggregator. Agents using smartphones to showcase e-commerce catalogs to customers and then gather their customer details also help to combine traditional face-to-face interactions with digital engagement tools, and allows for greater data capture in respect of cash sales customers.²²¹ In addition to direct customer engagement, ESSMART is amongst companies using digital catalogs to make new B2B connections with retail outlets.

218 GOGLA analysis and consultations.

219 *Business Daily* (2020), *Solar Firm d.light Settles Sh100 Million Loans for Covid-hit Customers*.

220 *Shamba Shape Up* (2022), *Welcome to Shamba Shape Up*.

221 GOGLA consultations.

Figure 48: The tech savvy urbanite²²²



Demographics

- Age: 32
- Gender: Male
- Family Status: Married with two children
- Location: Urban

Occupation

- Salaried office worker

Education

- Tertiary

Purchasing behavior

- Learns about new products through recommendations
- Learns about new products via billboards
- Learns about new products via social media, radio
- Buys in local retail outlets
- Makes non-daily purchasing decisions with his wife

Willingness / Ability to Pay

- Lives on under \$10 per day
- Some, limited savings
- Paid monthly

Goals

- Wants to get a more reliable electricity supply
- Aspires to own more appliances e.g. large TV, tablet, laptop

Pain points

- Intermittent 'brownouts' from weak grid
- Appliances are too expensive to buy outright

Owned devices

- Smart phone

Marketing strategies

- Sales via retail outlets
- Sales via partner channels (e.g. mobile phone shops)
- Engagement via social media, e-commerce platforms
- Offers and promotions around national holidays
- Analyze payment history and recommend new purchases via SMS



Increased awareness of off-grid technologies has also led to more marketing via partnerships. These are also playing a key role in the sale of agricultural products and services.

As the OGS market continues to mature, new partnerships are developing, including those in earlier stage technology segments, opening up new channels to engage audiences. Some OGS markets, such as Papua New Guinea, have developed via partnerships with established retail networks where SEK manufacturers can tap into existing audiences. Similarly, the Indian market has its foundations in partnerships with microfinance institutions. As the industry evolves, new partnerships continue to emerge, enabling solar manufacturers and integrated companies to connect with their partners' audiences. For example, on the retail side, Sun King is now selling products in the supermarkets Quickmart and Carrefour. Whilst amongst financial institutions, The National Bank of Kenya has partnered with Davis & Shirliff, a water pump company with a 75 year history in East Africa, to offer

three-year, no-interest, loans to its customers so they can purchase a solar water pump (see Section 5.2.2).²²³

Partnerships with agri-distributors are likely to be key to more rapid deployment of SWPs. As noted in Section 4.2, agri-retailers already have a customer base of smallholder farmers. SWPs are larger and more complex products than plug and play (PnP) solar energy kits and the knowledge that agri-sales teams already have on which products are suited to which water, soil and crop types is also beneficial in ensuring a sale is appropriate. Agricultural sales professionals are also more accustomed to selling higher price, business systems which require knowledge of their impacts on crop yields and diesel expenditure, in order to help customers understand how they will recoup the cost of the product. For example, while the SWP manufacturer FuturePump initially sold to off-grid solar distributors, it has expanded its reach to specialized agri-retailers significantly in the last two years. Meanwhile, Simusolar, a distribution company that focuses on PUE technologies, advised that connections with agricultural organizations, NGOs and programs play a key role in its sales strategy. Although sales of solar refrigerators and walk-in cold rooms are very nascent, similar trends to these observed for SWP are beginning to emerge between equipment manufactures and operators with agricultural specialist retailers and asset finance organizations.

²²² GOGLA analysis and consultations.

²²³ Davis & Shirliff (2022), Davis & Shirliff Partners with National Bank to offer Financing.

The importance of helping farmers and MSMEs to best understand both how to use, and how to maximize the use of PUE systems is also important for customer acquisition. For example, FuturePump has developed a ‘Train the Trainer’ approach to upskill their B2B customers (see Box 4), while SunCulture has developed training

materials for customers on improving crop outputs.²²⁴ In respect of the cold chain, Cold Hubs in Nigeria has similarly developed information for farmers on what produce can be stored, for how long and at what temperatures. Whilst Solar Cooling Engineering provides both in-person training and hosts an online course.²²⁵

Figure 49: The smallholder farmer²²⁶



Demographics

- Age: 46
- Gender: Male
- Family Status: Married with 4 children
- Location: Rural

Occupation

- Farmer

Education

- Tertiary

Purchasing behavior

- Learns about new products through recommendations
- Learns about new products in local market and via agri-networks/retailers
- Responsive to local agricultural initiatives to reduce SWP prices
- Makes purchases at harvest time

Willingness / Ability to Pay

- Lives on under \$5.50 per day
- Some, limited savings
- Some seasonal fluctuation in line with harvest, but may have additional income source

Goals

- To increase produce for family consumption
- To cultivate additional (small) areas of farmland
- To increase farming income

Pain points

- Old diesel water pump is inefficient
- Diesel is increasingly expensive

Owned devices

- Smart phone

Marketing strategies

- Traditional face-to-face approaches and/or via trusted networks
- Seasonal offers and promos in line with harvest and/or government schemes
- Connection via MFIs, farming groups or agri-retailers

Box 4: FuturePump: ‘Training the Trainers’ - making more, and appropriate, sales

FuturePump is a PAYGo enabled solar irrigation pump manufacturer, established in 2013. It sells three different pumps, targeting one-acre and two acre farms. The company works with a range of distribution partners. However, the last few years has seen more partnerships with agri-retailers, who see the potential of the technology and whose sales teams already have an understanding of electric or diesel-powered pumps.

This is a valuable knowledge set for both making sales pitches, and making appropriate sales, as different pump sizes and models best serve different farmers, and sales teams need to ask questions around the farm’s water source, crop types, soil quality, harvest times, and size to understand which pump is suitable. Sales teams explore how much additional income the customer is likely to make as a result of owning a pump, to ensure they will not become overburdened by repayments. Making inappropriate sales is costly for both the customer and companies involved in the value chain. For example, if a pump is mis-sold and does not work properly at harvest time, this can lead to significant losses for the customer. For companies, it could lead to low repayments, and a rapid reduction in consumer confidence, and/or damage to the pump.

Futurepump has therefore developed a ‘Train the Trainer’ approach to provide their distributors with ongoing training and weekly emails. These distributors in turn connect with their farming networks to demonstrate and educate them about the pumps - with the aim of making sales and building widespread trust in the technology.

224 [AgriFI Keyna Challenge Fund \(2022\), SunCulture.](#)

225 [Solar Cooling Engineering \(2022\), Welcome to Solar Cooling Engineering.](#)

226 [GOGLA analysis and consultations.](#)

4.4 The Role of Programs in Driving Customer Awareness and Impact



Awareness campaigns still have a strong role to play in driving access to off-grid solar solutions and can benefit from the insights gained from previous campaigns, as well as new marketing approaches.

Millions of people without electricity are living in countries affected by fragility, conflict and violence (FCV), with only nascent OGS markets and limited access to mass media. While affordability is a huge barrier to accessing solar energy kits, companies advise that awareness also remains a significant challenge. While in more remote areas of countries that have seen extensive solar energy kit sales, many people are still not aware of the range of technologies available, or their impacts. This is demonstrated by the success of the recent Lighting Global ‘Non-Stop Life’ campaign in India (see Box 5). Awareness campaigns in nascent and emerging markets are still needed to drive OGS adoption.

A lack of product awareness and trust is particularly prevalent for earlier stage PUE technologies, such as solar water pumps and cooling. This is illustrated in a

recent consumer awareness campaign on solar irrigation in Kenya. Kenya is one of the largest markets for OGS technologies, yet only 1% of farmers interviewed before the campaign were using an SWP. Following outreach to farmers and community engagement, 96% of farmers interviewed advised that they would consider purchasing an SWP following the campaign.²²⁷ However, a lack of clarity on how farmers would recoup costs and the need for them to save considerably to purchase a system meant that the campaign did not lead to immediate sales. This suggests that future campaigns may meet with more success combined with affordability initiatives.

Programs designed to open up new markets and reach new customer segments also create strong drivers for companies. For example, results-based financing (RBF) schemes can be used to target company reach towards customers in more difficult to access geographies, while end-user subsidies in Rwanda and Togo have enabled companies to connect low income homes, and households in a previously nascent market respectively (see Section 8.2.1).

While in-person demonstration and engagement remained core to the strategy, digital engagement and the partnership with the women’s network were highly successful additions. The latter as the networks were already established and trusted within their communities so well-placed to make direct sales. The success of these elements hinged on access to smartphones among rural populations in India, with penetration now estimated at 70-80%, and the relevance of the chosen partner.

Future programs can use lessons from the Lighting Global experience and the growing range of marketing approaches to maximize the success of awareness campaigns.



© Power Africa

²²⁷ *Efficiency for Access Coalition (2022) Solar Water Pump Consumer Awareness Raising Campaign Readout.*

Box 5: Lighting Global 'Non-Stop Life' India campaign: A hybrid approach

To catalyze off-grid markets, the Lighting Global Program spearheaded several OGS consumer awareness campaigns between 2014 and 2021. The initial campaigns involved a distinct brand and messaging, with trained marketing teams hosting promotional events in villages run from a branded van 'hub' from which they hosted street theater, music, games and prizes. The campaigns were run in collaboration with off-grid companies.

Due to COVID-19, the recent 'Non-Stop Life' campaign in India was forced to adapt its approach, and in doing so developed a hybrid campaign that used both traditional OGS marketing techniques and newer SMS and digital media methods. Adjustments included:

- Using a smaller van from which teams went house-to-house to avoid gathering large groups
- Focussing on digital presence and engagement, including videos on YouTube, Facebook and WhatsApp
- Using 'local area SMS messaging, by zip code, to provide localized promotions
- Working with a network of female direct sales entrepreneurs who visited the same households a few days after the event

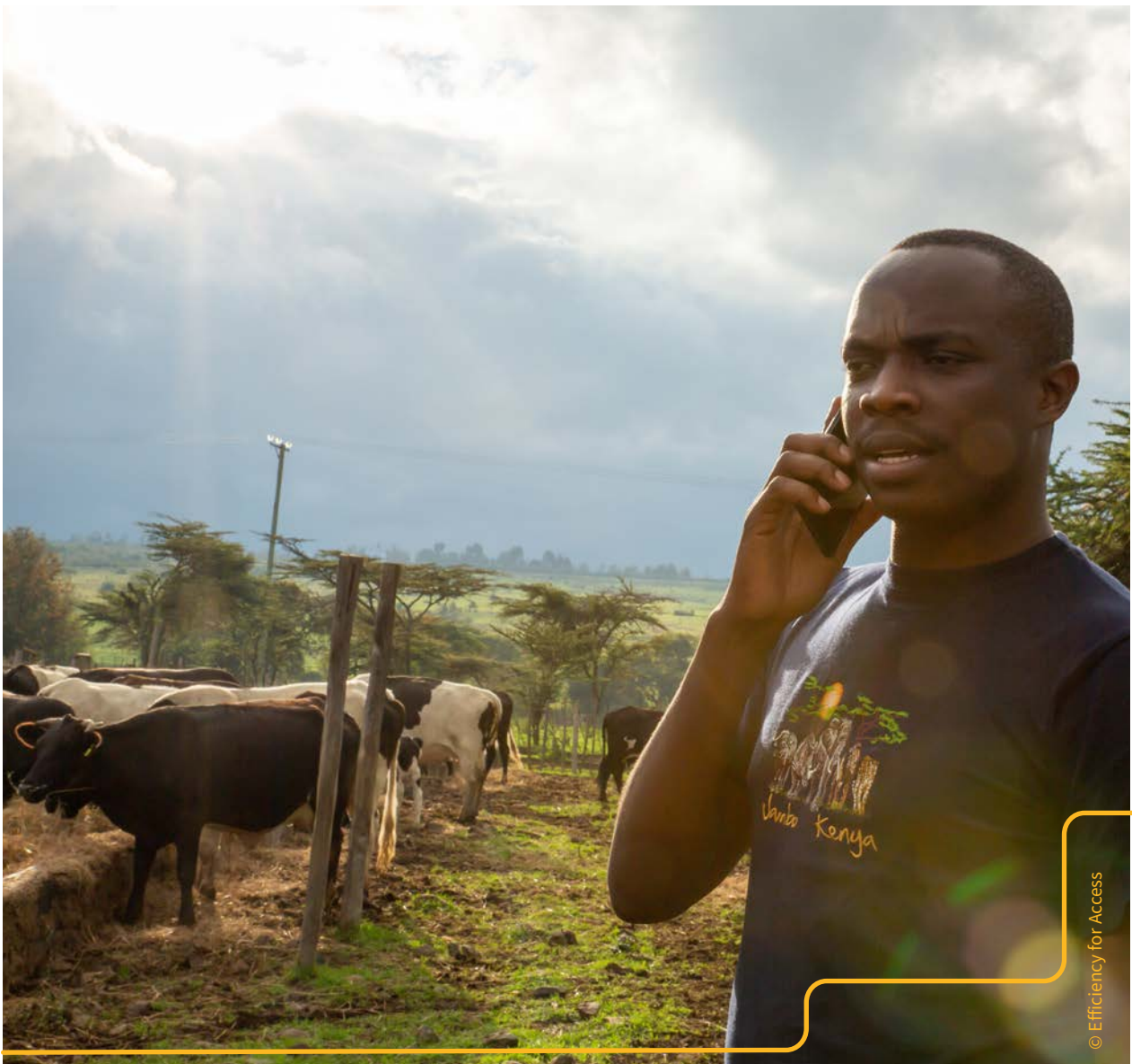



05

Market
Landscape

KEY MESSAGES

- The electricity access gap is concentrated in countries where the off-grid solar market remains nascent
- The market for some household appliances is reaching maturity, while most dedicated productive use of energy technologies are still relatively nascent
- Although competition continues to be driven by price, recent supply chain challenges have affected product availability and provided advantages for companies with sufficient stock levels
- A number of off-grid solar companies now report to be fully profitable, whilst others report to be partly profitable (e.g. for operations in key country markets or business functions such as manufacturing). This has enabled some companies to unlock a wave of investment from a new, later-stage, commercial investor base
- Achieving profitability remains a key driver for companies in the off-grid solar industry, spurring trends on cost-cutting, and increasing sales volumes and customer segment diversification

5.1 Market Classification



Most off-grid solar sales are into relatively mature markets, while much of the remaining need is concentrated in markets where the off-grid solar sector is nascent or still emerging.

This section classifies national off-grid solar markets in terms of market maturity based primarily on a combination of cumulative sales penetration and recent sales growth rates. The analysis presented is based solely on the sales of solar energy kits and lanterns, as there is a long and robust database of sales data for these products from affiliates dating back to 2014. This classification includes appliances to the extent that these are often sold as part of bundled kits (as described in Section 2.2), but may not necessarily reflect how markets are evolving for standalone appliances or for productive use technologies such as solar water pumps. For some products these markets may be reinforcing - for example availability of appliances such as TVs may reinforce demand for solar energy kits, while it is also possible especially for some PUE technologies that markets may evolve to maturity separately from the precedent set by SEKs.

Recent trends in market evolution are across four market classifications:

- **Nascent** - a substantial electricity access gap remains (at least 5% of the population), with minimal sales volumes (reaching less than 10% of market potential). Nascent markets often still show slow growth rates, or

are beginning to show high growth rates but that have not yet been sustained long enough to achieve more than 10% market penetration.

- **Emerging** - a substantial electricity access gap remains (at least 5% of the population) and SEK sales already reach a significant share of the potential market (at least 10% of the potential market). In general, emerging markets are still on a growth trajectory which slows as they mature, although some emerging OGS markets may experience periods of slower growth / stagnation in sales.
- **Mature** - sales reach a high share of the potential market (around 50% or more of market potential), with sales continuing to grow and/or stabilizing.
- **Peaked** - the electricity access gap is closing significantly and either OGS unit sales are starting to decline or the remaining electricity access gap is less than 5% of the population.



Figure 50: Electricity access deficit and OGS sales by market type²²⁸

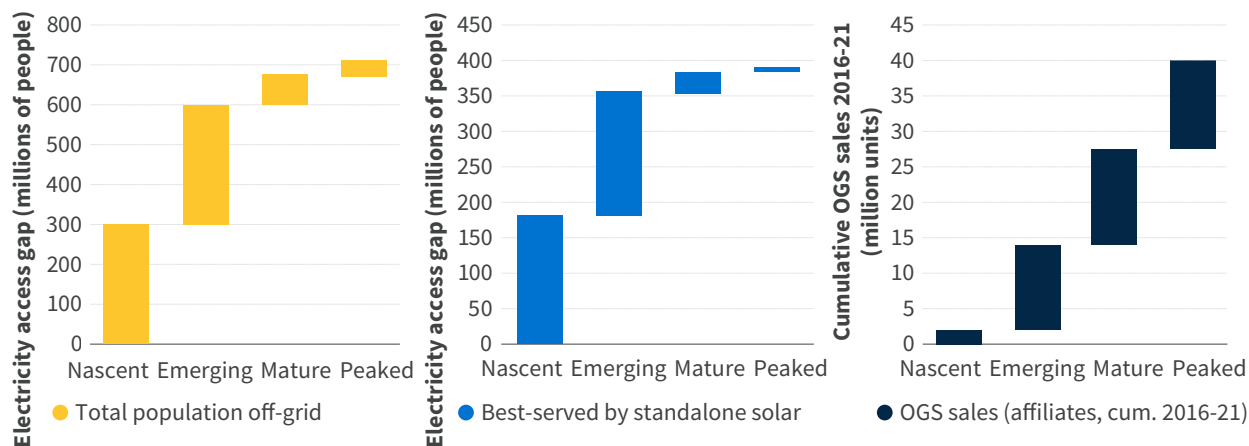

OGS technologies have made a significant contribution to closing the electricity gap in relatively mature markets. Figure 50 shows affiliates have sold over 10 million units since 2016 in each of the emerging, mature, and peaked categories.

Penetration of OGS technologies is lagging in nascent markets, where the need is greatest. Just two million affiliate unit sales have reached nascent markets since 2016, representing 5% of total affiliate sales. Yet, around 298 million people still lack access to electricity in these countries, and most (61%) would be best served by OGS technologies.²²⁹ Public finance, including subsidies, will have a key role to play in accelerating access while catalyzing commercially sustainable markets in contexts which are often highly fragile and conflict affected, with low ability to pay, and limited infrastructure to reach rural communities.

Emerging OGS markets are characterized by both high penetration of sales and a large remaining electricity access gap. Since 2016, around 12 million affiliate units have been sold in these markets (30% of the total), but over 300 million people still lack access to electricity, of which 58% would be best served by OGS technologies.

In mature and peaked markets the electricity access gap is narrowing and OGS is playing a key role in making sure no one is left behind. The electricity access gap even in these mature markets remains over 5%, and those communities currently without access to electricity will often be those that are either extremely poor and/or remote, conflict affected, and expensive to reach. Their

communities are not commonly served by commercial OGS market activity and will need support from public subsidies (described in Section 8.2.1). Across mature and peaked markets more than 100 million people still lack access to electricity. Around 34 million would be best reached by standalone solar technologies. Low-capacity and/or low-quality products are still common in mature markets, so there may remain a market opportunity for higher quality systems and for households to move up the energy staircase. In some mature and peaked markets, OGS technologies are increasingly deployed alongside a weak grid connection to improve the quality of electricity access.



²²⁸ Analysis of SDG7 tracking data, population data from UN Population Division, least-cost electrification pathways from the Global Electrification Platform for new connections between 2020-25 (low demand scenario), GOGLA sales data, and a mapping of national markets to each classification.

²²⁹ Through this section, the share of population best served by OGS is based on analysis of the Global Electrification Platform, 'Low Demand' scenario between 2020 and 2025. Affiliate sales are based on data reported to GOGLA, while the population without access to electricity is based on SDG7 tracking data.

Figure 51: Market classification²³⁰

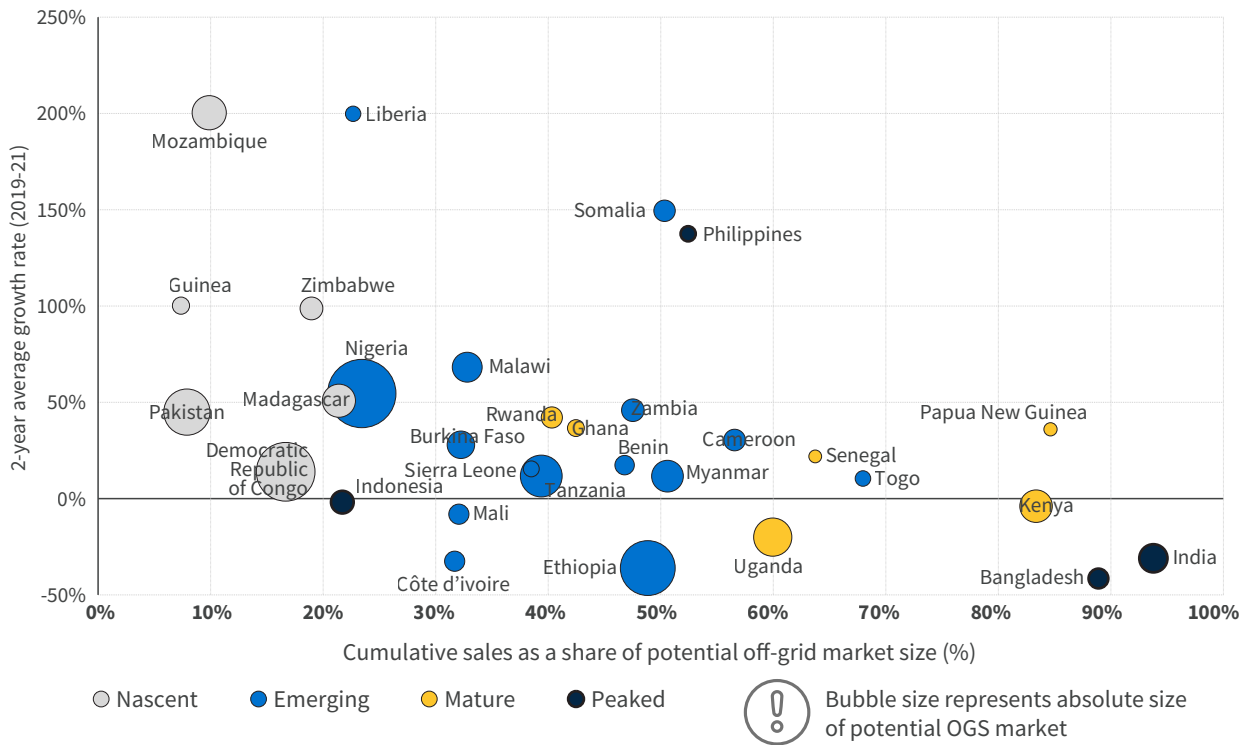

Nascent markets

Angola, Burundi, Central African Republic, Chad, Congo, Democratic Republic of Congo, Gambia, Guinea, Haiti, Madagascar, Mauritania, Mozambique, Namibia, Niger, Pakistan, Sudan, South Sudan, Yemen, Zimbabwe

298 million
people currently
without access to
electricity

61%
best reached
by SEKs

100
average
fragility

2 million
recorded SEK
sales since 2016

In many countries, the off-grid solar sector remains nascent. The need for electricity access is great, with just under 300 million people lacking access, accounting for 41% of the remaining electricity access gap. Sales are not reaching these markets at scale, comprising just 5% of affiliate SEK sales since 2016.

These countries are often characterized by a degree of fragility, conflict, and violence. On average, people living in countries with nascent OGS markets are in states with a

'Fragile States Index' score of 100 over the past five years.²³¹ This is significantly higher than countries that have successfully developed mature, or even peaked, off-grid solar markets.

This context makes for a challenging environment for commercial off-grid solar ventures. Nascent OGS markets, since the ability of households to pay is limited, with a high incidence of poverty and the cost of operating securely and reaching remote rural populations is high.

²³⁰ Notes: [1] 2-year growth rate is an average of the last two year on year growth rates, calculated from GOGLA half-yearly market reports, [2] Cumulative sales as a share of off-grid market size is estimated based on the cumulative sales since the beginning of 2016 of both GOGLA-affiliate and non-affiliate sales, divided by the total sales PLUS the remaining electricity access gap as reported in the SDG7 tracking reports, [3] Bubble sizes are based on the absolute market size of the remaining electricity access gap, as reported in the SDG7 tracking reports, [4] Sales growth is capped both at the top and the tail at 200% and -50% respectively for display purposes only. So some countries appearing at 200% may have had a higher growth rate than 200%, and some appearing at -50% may have shrunk by more than 50%, [5] Countries included in this classification exclude those with high levels of electricity access and/or where there is no previous record of OGS sales - this comprises around 710 million people of the total global electricity access gap of 733 million people.

²³¹ Fragile States Index | The Fund for Peace; The index scores 178 countries on 12 indicators spanning cohesion, economic, political and social factors.

In these instances, the enabling environment of policies and regulations is relatively weak, which does not give the private sector enough certainty over operations to plan several years ahead. For example, countries such as Burundi in East Africa, South Sudan in Central Africa, or Chad in the Sahel region of West Africa all have electricity access deficits in excess of 80% of the population but only see a few thousand off-grid solar unit sales recorded by affiliates each year. In Asia, while many countries have seen rapid progress in closing the electricity access gap over the past decade, the electricity access gap in Pakistan is still large (see Section 1.1), and GOGLA affiliate off-grid solar sales are still relatively low compared to the size of the market.

Some nascent markets have emerging off-grid solar ecosystems, often driven by local companies, while support for electricity access programs can help drive

the transition towards ‘emerging’ markets. Altech is an example of a local operator gaining traction in DRC. Affiliate data reveals that while only 41 companies were reporting sales in nascent markets in 2016, 80 companies were doing so in 2021, showing a gradual growth of actors operating in these countries.²³² International companies have also entered some nascent markets that have made the step to, or are on the way towards, ‘emerging’ status, often drawn by incentive programs such as BRILHO Energy Africa Program in Mozambique, which launched its second round in 2022 to support companies providing clean energy to households and MSMEs (see Section 7.1).²³³ In some nascent markets donor support is also playing a crucial role in accelerating electricity access in contexts which are unlikely to have the conditions for commercial market sustainability (see Box 6).

Box 6: Challenges and lessons learned in increasing electrification in Chad and Mozambique

Chad has one of the world’s lowest electrification rates worldwide at just 6.4% in 2020. Its off-grid solar market remains at a very early stage of development. Most of the population relies on kerosene lamps and expensive diesel generators for lighting, and the PUE appliance market has been predominantly driven by NGO programs.²³⁴ Chad’s economy is also struggling following a recession in 2020 (-0.9% GDP growth), with 33.2% of the population living on less than \$1.9 a day as of 2018.²³⁵ Not only limited purchasing power but also security risks especially in border regions, and lack of policies and regulations to encourage private investments, hold back private sector developers including in the OGS sector.²³⁶

The Government of Chad (GoC) is committed to developing the OGS sector, recognizing access to electricity as a key economic driver. The 2020 National Emergency Electricity Plan (NEEP) set a target of 53% electrification by 2030, renewable energy is planned to supply 20% and includes off-grid solutions.²³⁷ This policy commitment is supported by programs like (1) the Chad Energy Access Scale Up Project, approved by the World Bank in 2022 and (2) the Regional Off-Grid Electricity Access Project (ROGEAP). ROGEAP was launched by ECOWAS and partly funded by the World Bank in 2021 to foster an enabling environment for OGS businesses, including PUE companies, and to enable access to growth capital.²³⁸ These efforts are expected to drive sector development forward.

In contrast, Mozambique is beginning its transition towards an emerging OGS market. Mozambique had similar electrification rates to Chad 20 years ago.²³⁹ Since then, the country has made substantial progress. Electrification rose to 40% in 2021 with the growing off-grid sector electrifying 1.4% of the population in 2019.²⁴⁰

Government and development partner programs, and enabling policies and regulations are some of the factors contributing towards driving development of Mozambique’s OGS sector. The BRILHO RBF program to support OGS sector development

232 GOGLA analysis of data collected for the Global Off-Grid Solar Sales and Impact Reports 2016-2021.

233 SNV (2022), [BRILHO Launches Second Call for Applications to Support Businesses in Mozambique](#).

234 Lorentz (2014), [Solar Drinking Water Supply Am Nabak, Chad](#); UN Climate Technology Center and Network (2013), [SolarChill - Refrigerators and Vaccine Coolers Powered by the Sun](#).

235 The World Bank (2018), [Poverty Headcount Ratio at \\$1.90 a day \(2011 PPP\) \(% of population\) - Chad](#).

236 The World Bank (2021), [Chad Energy Access Scale Up Project: Project Information Document](#).

237 Afrik21 (2019), [Chad: State targets 20% RE in its Energy Mix by 2030](#).

238 The ECOWAS Center for Renewable Energy and Efficiency (ECREEE), [Regional Off-Grid Electrification Project \(ROGEP\)](#); The World Bank (2019), [Regional Off-Grid Electricity Access Project; Lighting Africa \(2017\), Regional Off-Grid Electrification Access Project \(ROGEAP\) Overview](#). Note: The project aims to reach 47.2 million people (across all target economies) through OGS solutions by 2030. The GoC has also been increasing budgetary allocations annually (eg., \$76 million in 2018, up from ~\$38 million in 2014) to fund OGS projects.

239 OECD (2002), [Mozambique Country Report](#).

240 World Bank, IFC, GOGLA (2020), [Off-Grid Solar Market Trends Report 2020](#).

was launched in 2019, and continues to see support by international donors such as SIDA in 2021 (see Section 7.2).²⁴¹ Additionally, in 2021, the GoM approved a new Regulation on Access to Energy in Off-Grid Zones policy to improve regulation for off-grid power provision through mini-grids, SHS and other SAS solutions. Although implementation specifics are yet to be determined, the policy is expected to attract increased investment into the sector and promote further electrification through OGS solutions.²⁴² These initiatives and others by development partners are some of the factors driving OGS sector development and electricity access over the last few years.²⁴³

As a result, the OGS market has grown substantially, encouraging local and international companies to enter the space. The sector has grown significantly compared to other nascent markets, making Mozambique an encouraging example for countries that are at an earlier growth stage. This is exemplified by over 20 companies that were present in the country by 2019 selling quality-verified SHS brands, with four of them offering these products on PAYGo.²⁴⁴ The OGS sector in Mozambique still faces barriers to development. These include poor consumer awareness and perception of OGS products; and ongoing macroeconomic uncertainty, mainly caused by its hidden debt crisis uncovered in 2018 and insecurity in the northern part of the country.²⁴⁵

Emerging markets

Benin, Burkina Faso, Cambodia, Cameroon, Côte d'Ivoire, Ephiopia, Liberia, Malawi, Mali, Myanmar, Nepal, Nigeria, Sierra Leone, Somalia, Tanzania, Togo, Zambia	305 million people currently without access to electricity	58% best reached by SEKs	93 average fragility	11.9 million recorded SEK sales since 2016
---	--	---------------------------------------	-----------------------------------	---

Emerging markets account for a high share of OGS sales, with a substantial electricity access gap. There is still a large electricity access gap in these countries, comprising 43% of the remaining electricity access gap. There is also a large emerging off-grid solar market, accounting for 30% of off-grid solar sales since 2016.

Most of these markets are characterized by a degree of stability that enables market expansion, with high sales growth. In West Africa, several countries have sustained growth over the last four years, including some of the fragile and conflict-affected states in the Sahel such as Burkina Faso and Mali. Governments and partners are

commonly providing incentives such as subsidies and RBF to support market development, while PAYGo is beginning to overtake cash-based sales, and there is an ecosystem of both local retailers and major international companies. For example:

- Togo has had high growth in affiliate sales for several years as the national CIZO program is implemented²⁴⁶
- Nigeria saw relatively stable affiliate sales of around 300,000 units per year in 2018, 2019 and 2020, although this expanded to over 600,000 in 2021 (see Box 7 for further discussion)

241 [BRILHO \(2022\), Home Page.](#)

242 [Brookings \(2022\), An Increased Role for Private Sector: Mozambique's New Regulatory Policy in the Off-grid Energy Sector.](#)

243 Notes: [1] The World Bank approved a 5-year Mozambique Energy For All (ProEnergia) project to support electrification of per-urban and rural areas through various forms of energy access solutions including OGS; [2] GIZ and Fundação para o Desenvolvimento da Comunidade (FDC) set up the FASER RBF to enable the most vulnerable communities, women and populations in off-grid areas to have access to renewable energy, including PV solar systems and SWPs [3] COVID-PAY and COVIDPlus, two funding mechanisms under FASER, were launched during the pandemic to support OGS companies [4] The government introduced temporary tax waivers on quality-verified OGS products and is working to improve awareness and reach of mobile money to further drive OGS sector development. For more information, please see: [The World Bank \(2022\), Mozambique Energy For All. \(ProEnergia\); EnDev \(2020\), Energizing Development Progress Report 2020; Faser | Home; Economic Consulting Associates and GreenLight \(2018\), Off-Grid Solar Market Assessment in Mozambique\).](#)

244 [Greenlight Africa \(2019\), Mozambique - Off-grid Energy Market Assessment.](#)

245 [Global Green Growth Institute \(2019\), Country Brief: Mozambique Off-grid solar Power in Mozambique: Opportunities for Universal Energy Access and Barriers to Private Sector Participation.](#)

246 In general for market classification total sales are scaled up on the basis of non-affiliate sales growing in line with affiliate sales. However, this may not always be the case, in particular in a case like Togo where the 2018 market assessment estimated non-affiliate sales comprise 96% of sales, but this is likely to have changed significantly as a result of CIZO which has catalyzed a rapid uptick in affiliate sales. For this reason, for Togo, we instead cap the non-affiliate sales at, which may not always be the case, especially in a context like Togo where CIZO has catalyzed especially affiliate sales.at 90% for the purposes of the classification.

- Burkina Faso and Mali have developed relatively active off-grid solar markets, including some local manufacturing and end-of-life repurposing / recycling through companies like Lagazel
- Myanmar was showing signs of strong growth in sales of OGS products up to 2020, although the market has been negatively impacted by COVID-19 in 2020 and the coup in 2021

Box 7: OGS electrification projects and PAYGo development boosting electricity access in Nigeria

Some emerging markets have made great strides in bridging their electrification gaps, including OGS technologies. Nigeria has a large population of 200 million people and a 45% national electrification gap as recorded in 2019.²⁴⁷ The government aims to achieve 100% electrification by 2040, with a target of 5% provided through off-grid solutions. Besides this target, there is also a strong case for OGS as a weak grid solution, as only 25% of grid-connected consumers receive up to four hours of power daily.²⁴⁸ The rationale behind the Rural Electrification Agency's (REA's) programs suggests that the role of OGS is likely much larger than 5% given it can act as a temporary electrification solution to bridge the gap before planned grid or mini-grid developments are executed.

National programs and enabling policies and regulations have strengthened the country's OGS market's potential and translated into product uptake.²⁴⁹ The Solar Power Naija Program (SPN) launched by the government in 2020 aims to support 5 million new OGS connections for households and MSMEs.²⁵⁰ The program also has goals of growing local manufacturing and supporting installation of PUE appliances (see Section 7.2).²⁵¹ The Nigeria Electrification Project's (NEP) RBF program, aimed at increasing electrification through mini-grid and standalone solar connections, recorded substantial progress, reaching 250,000 connections from Tier 1+ solar energy kits in 2021 alone. Additionally, the program has helped to drive activity in the wider market. Affiliate sales of SEKs in 2020 were 300,000 but reached 630,000 in 2021, with growth seen in the sales of lanterns, TVs and fans that were not covered by the subsidy.²⁵² Despite these significant milestones, there is unleveraged potential and barriers to the off-grid sector's growth, including product quality promotion to address risk of low quality products, and increased tax exemptions for solar accessories and appliances to attract players to the market.

Mature markets

Ghana, Kenya, Papua New Guinea, Rwanda, Senegal, South Africa, Uganda, Vanuatu	71 million people currently without access to electricity	41% best reached by SEKs	87 average fragility	13.7 million recorded SEK sales since 2016
--	---	------------------------------------	--------------------------------	--

While growth rates may be beginning to stabilize, mature markets dominate OGS sales volumes and make a significant contribution to bridging the electricity access gap. The electricity access gap is narrowing; just 10% of people lacking access to electricity live in countries with mature OGS markets. Nonetheless, there is still the need and market opportunity for OGS, as over 30% of people in mature countries still lack access to electricity. Mature markets account for 34% of off-grid solar sales over the last three years.

Mature markets are often, but not always, characterized by a high share of PAYGo sales, relatively strong quality

assurance, and policy stability. For example, Kenya and Rwanda have achieved stable sales volumes and high penetration of off-grid solar products, while implementing robust quality standards. Kenya remains the clear market leader, with around two million sales recorded by GOGLA each year, over half of which are sold through PAYGo. In countries which have made a relatively quick transition through emerging to mature such as Papua New Guinea, cash over-the-counter sales are often the main driver of sales, and non-quality verified, relatively small capacity products are still highly prevalent. In this context there is still a large market opportunity even in mature markets, as customers begin to replace their products with higher

²⁴⁷ IASS (2022), *The Nigerian Electrification Project*.

²⁴⁸ ACE (2021), *Stand-alone Off-grid Solar Nigeria*.

²⁴⁹ Note: In 2018 the GoN launched the Nigerian Electrification project with the World Bank and the African Development Bank to provide electricity access to under and unserved communities using renewable energy resources.

²⁵⁰ Rural Electrification Agency (2022), *Solar Power Naija: Enabling 5 million New Connections*.

²⁵¹ *Ibid.*

²⁵² GOGLA (2022), *Global Off-Grid Solar Market Report Semi-Annual Sales and Impact Data H2 2021*.

capacity and higher quality products, potentially supported by increased availability of PAYGo enabled products.

Even in mature countries, supportive financing is key to electrifying hard-to-reach regions which are not commercially viable markets. For example, regions in extreme northern Kenya such as Mandera and Turkana are characterized by relatively low ability to pay, hard-to-reach

communities which are not served by commercial business models. To incentivize OGS companies to reach these communities, governments and development partners need to work together to provide public subsidies (e.g. through RBF), such as KOSAP in Kenya and the Renewable Energy Fund in Rwanda (see Box 8).

Box 8: Support is still needed to incentivize OGS companies to reach unserved population targeted for OGS electrification in Rwanda

Countries in mature markets continue to grow albeit slower than they have in the past. As of Q1'2022 ~21% of Rwandan households were connected by off-grid solutions, not too far from the recently revised target of 30% electrification through off-grid technologies by 2023/2024 as laid out in the country's National Electrification Plan (NEP) by 2024.²⁵³

In a bid to accelerate the implementation of the NEP, the government and development partners have been instrumental in supporting OGS sector development. The government developed a Rural Electrification Strategy in 2016 and has so far signed a memorandum of understanding (MOU) with 21 private companies to increase the supply of SHS. These partnerships have improved Rwanda's supply chain and brought solar systems closer to consumers countrywide.²⁵⁴ As a result of efforts to grow the sector, in the first half of 2021, the country recorded sales of over 97,000 solar lanterns and multi-lights systems, and SHS; a 30% increase from the second half of 2020.²⁵⁵ The PUE market is also a focus area for OGS development. For example, between 2018 and 2020, Energy 4 Impact implemented the Solar Irrigation Rwanda (SIR) program, which saw 1,450 farmers adopt solar irrigation systems.²⁵⁶

However, with the commercially viable market being nearly saturated, reaching the remaining 9% allocated for electrification through OGS by 2024 will likely be challenging. With the remaining market being largely composed of households in hard-to-reach areas with limited ability to pay, government and development partner funded programs have to remain an integral part of the OGS electrification strategy. To address this, in 2020, the government added to the existing Renewable Energy Fund (REF) a \$15 million subsidy window called the RBF Window 5 to provide SHS to a minimum of 445,000 off-grid households and a \$20 million guarantee framework to support banks that lend to OGS companies.²⁵⁷ The RBF Window 5 was designed to address affordability of SHS through reduction of product prices with the goal of reaching BoP consumers in Rwanda, channeled through partner OGS companies.²⁵⁸

Peaked markets

Bangladesh, Guatemala, India, Indonesia, Peru, Philippines, Thailand	33 million people currently without access to electricity	15% best reached by SEKs	78 average fragility	12.5 million recorded SEK sales since 2016
--	---	------------------------------------	--------------------------------	--

253 [Rwanda Energy Group \(2022\), Electricity Access.](#)

254 [Rwanda Energy Group \(2022\), Solar Home Systems.](#)

255 [GOGLA \(2021\), Global Off-Grid Solar Market Report Semi-Annual Sales and Impact Data H1 2021.](#) Note: Other efforts introduced in the past to develop the sector include the introduction of fiscal incentives, such as tax exemptions for some solar equipment, and the launch of industry associations such as the Energy Private Developers association (EPD). For more information, please see: [GOGLA \(2022\), Rwanda Country Brief.](#)

256 [Energy 4 Impact \(2021\), Solar Irrigation Rwanda.](#) Note: The Solar Irrigation Rwanda (SIR) by Energy 4 Impact implemented between 2018 and 2020, addressed affordability challenges through leveraging subsidies and loans resulting in 50% to 75% of equipment cost reductions and contributing to product awareness.

257 [MININFRA \(2020\), Government Launches US\\$35 Million Solar Project For Rural Households.](#)

258 [The World Bank \(2020\), Restructuring Paper On A Proposed Restructuring Of The Rwanda Renewable Energy Fund Project; Rwanda Energy Group | RBF Window 5; Rwanda Energy Group \(2021\), RBF Window 5 – A New Subsidy to Enable 370,000 Households get Solar Home Systems.](#)

A handful of markets show signs of having peaked, with unit sales declining. The electricity access deficit in these countries is now relatively small, accounting for just 5% of people still lacking electricity worldwide. OGS sales even if declining are still large in absolute terms, accounting for 31% of affiliate sales since 2016.

In these markets the main grid has expanded and OGS sales are approaching saturation. As the grid reaches almost all communities, OGS technologies are evolving to play a dual role. Firstly, to serve a small part of the market that is remote that the grid cannot yet reach, and increasingly, to provide a secondary source of power alongside a weak main grid connection to enhance the quality of electricity access for households and businesses.

There is still a significant market in absolute terms. For example, two of the largest OGS markets historically, India and Bangladesh, have seen both a rapid roll-out of the main grid and high penetration of OGS sales. Yet, in absolute terms, they ranked 2nd and 20th for absolute sales recorded by GOGLA in 2021.

There is also an opportunity for the role of off-grid technologies to evolve alongside the main grid. As described in Section 2.1, off-grid solar solutions are already playing an important role alongside weak grid connections, particularly relevant in these markets where the grid has expanded its reach quickly but a fully reliable service may still be many years away. In part driven by a recognition of the limitations of the reliability of the main grid, some governments are explicitly planning for distributed renewable energy to drive productive use, such as SWPs by farmers. For example, both India and Pakistan have introduced net metering for residential and commercial buildings, and implemented off-grid solar water pump programs, with potential interconnection to regional electricity grids (see Box 9).

In general, even as a handful of markets pass the peak of OGS unit sales, there remains significant potential for the market for these technologies to evolve. As described in Section 2.1, there is still an important role for solar technologies to play alongside the grid, for productive use in agriculture and small businesses, and for even a small share of households to transition to larger SHS as they ascend the energy staircase.

Box 9: Unreliable grid solutions and PUE appliances present new opportunities for OGS companies in India

Targeted government initiatives over the last decade played a significant role in India's drive to universal electrification. Currently only 2.4% of households in India do not have access to electricity.²⁵⁹ This is attributed to the government's grid expansion efforts and launch of various support programs implemented since 2014, that included the supply of solar energy kits including maintenance services over a five-year period for households too remote to access grid connections.²⁶⁰

While the OGS market is declining, unreliable grid connection in rural areas presents a need for PUE appliances and rechargeable batteries. Although 97% of the population has access to the grid, customers' grid connections are often unreliable, affecting households and businesses. As a result, energy companies started diversifying their product portfolios beyond OGS, to include rechargeable batteries to meet customer demand. These batteries are charged when grid electricity is available and used when it is unavailable. PUE appliances, milk chilling facilities and SWPs, in unreliable grid areas are also an attractive product category.

In 2019, the government's Ministry of New and Renewable Energy launched the PM-KUSUM Scheme to improve energy security for farmers. The scheme included one component to co-finance the purchase and installation of two million standalone SWPs and another to support the solarization of 1.5 million existing grid-powered pumps to increase energy reliability.²⁶¹ 30% of the cost is provided as a State Government subsidy, 30% as financial assistance from the Central Government (50% in North Eastern States) and 30% is a loan to the farmer who would cover the remaining 10% out-of-pocket. However, while the scheme has facilitated the installation of over 110,000 solar water pumps, when compared to the initial ambition of installing 1.75 million SWPs by 2022, implementation has been slow. This is due to challenges such as poor coordination between implementing partners and the government, and difficulties experienced by farmers in obtaining financing from banks.²⁶² This program, if current implementation challenges are resolved, will be instrumental in driving demand and uptake of SWPs in India.

²⁵⁹ [Council On Energy, Environment And Water \(2020\), State of Electricity Access in India: Insights from the India Residential Energy Survey.](#)

²⁶⁰ Notes: [1] The Saubhagya scheme was launched in 2017 providing free or highly subsidized grid connections for unconnected and off-grid households [2] The OGS PV Application program launched in 2014, which was one of the government's first initiatives to provide solar based solutions. For more information, please see: MNRE | Brief on Off-grid PV Programme.

²⁶¹ [National Portal of India \(2022\), PM-KUSUM \(Pradhan Mantri Kisan Urja Suraksha evam Utthaan Mahabhiyan\) Scheme.](#)

²⁶² [Energy Tracker Asia \(2021\), KUSUM: Bumpy Ride for India's Solar Pump Scheme; MNRE \(2021\), PM KUSUM Scheme.](#)



Productive use of energy technologies are still at an early stage of market development, tending to follow established off-grid solar markets.

Household appliance markets are often reinforcing the maturity of the market for solar energy kits. There is a moderate-to-high correlation between sales of refrigeration units, TVs and SEKs (Table 1), as appliances both support and can help drive sales of solar energy kits. For example, Kenya is the world leader for cumulative TV sales, and second only to India in terms of SEK sales.

The market for off-grid fans is thriving in countries where SEK sales are not showing the same growth or are declining. This is particularly the case in South Asia where Pakistan, Bangladesh, and India are the top three ranking countries for fan sales, but where SEK sales are declining (India and Bangladesh) or not showing the same high rates of growth (Pakistan). This is driven to a large extent by demand for fans alongside weak grid connections. It is worth noting that in SSA sales of fans appear to be predominantly bundled with PAYGo SHS, suggesting that in Africa they may follow the same trajectory as noted for other appliances above.

The emerging solar water pump (SWP) markets are all in relatively mature (including peaked) off-grid solar markets. Kenya, Senegal, Uganda, Bangladesh all have recorded SWP sales from GOGLA affiliate companies, while India has also deployed tens of thousands of SWPs. Togo is also rolling out SWPs supported by public subsidies. In general, emerging markets for SWPs appear to have both relatively developed SHS ecosystems, and support from public funding. This seems to suggest that specific PUE technologies may be following markets which have previously developed supporting policy and regulatory environments for solar energy kits, and where how to unlock demand for productive use of solar energy products is better understood.

Table 1: Correlation between SHS sales and appliances / PUE sales²⁶³

Appliances / PUE product segment	Correlation with cumulative solar energy kit sales (2016-21)
All Appliances	0.53
Solar Water Pumps	0.60
Refrigeration Units	0.59
Televisions	0.59
Fans	0.12

5.2 Market Competition

5.2.1 Solar Energy Kits Market Competition²⁶⁴



Although competition continues to be driven by price, recent supply chain challenges have affected product availability and provided advantages for companies with sufficient stock levels.



© Power Africa

²⁶³ Analysis based on GOGLA affiliate sales data only. Note: the correlation coefficient is a number between zero and 1, where zero would represent no correlation, and 1 perfect correlation. The closer the coefficient is to 1, the higher the degree of correlation between the two data series.

²⁶⁴ Analysis on market concentration and competitive trends in this section is limited to affiliate companies that report sales every year. Some report consistently while others may fail to report in some periods. Analysis in this section therefore relies on sales reported in each period and market by affiliate companies and reference to market entries and exits could be informed by reporting trends.



A range of factors influence competition in the OGS sector, including product type, geographical region, and affordability. Price remains a crucial element driving competition in the sector while product quality is beginning to influence competition, especially in mature markets. For example, in Kenya, quality was one of the main aspects of consideration for customers purchasing SHS, for both quality-verified and non-quality verified brands.²⁶⁵

Over the last two years, stock availability, due to supply chain challenges caused by COVID-19, was a key factor driving competition. During the pandemic, global supply chain disruptions, such as shipping delays and increased logistics costs and availability, not only raised the overall cost of products leading to a general decline in sales but also caused stock shortages.²⁶⁶ Some companies mitigated these challenges by exploring alternative product brands for distribution from suppliers with stock on the African continent. Others, like Anuel Energy in Uganda, adopted modular systems, replacing plug and play (PnP) systems by purchasing different components and assembling them locally.²⁶⁷ Companies that either had sufficient stock levels in-country or that were able to innovate around the stock challenges had a competitive advantage during this period. The continued global shortage of parts, such as semiconductors, alongside the high demand for batteries outside of the off-grid industry, mean that the availability and cost of components remain an industry challenge.

Evaluating the level of competition in the sector is difficult because little information is available on the non-affiliate portion of the market. While GOGLA collects sales data on the affiliate portion of the market, no such centralized database exists for the non-affiliate segment. Studies conducted by Ipsos on behalf of Lighting Global shed some light on the non-affiliate portion of the market but have not been updated over the last two years. The analysis in the remainder of this section is thus focused on data from the affiliate market segment, which are likely indicative of broader competitive trends but have been observed based on affiliate-only data.

Sales in the affiliate OGS market are dominated by vertically integrated companies, however more distributors are entering the market and partner with Chinese manufacturers, indicating increased competition.

Sales in the affiliate OGS market are dominated by a few vertically integrated companies, through both B2B and direct distribution. These companies are enabled by sufficient levels of funding. Some examples of vertically integrated companies that have recently secured investment to expand PAYGo operations across key new African markets include the following: Bboxx raised \$15 million in debt in 2022, Sun King raised \$260 million in Series D funding in 2022, and d.light raised \$25 million in equity in 2021 (see Chapter 8 Funding Flows).²⁶⁸

However, more distributors entering the OGS market and a gradual increase in the number of Chinese original equipment manufacturers (OEMs) quality-verifying their products through VeraSol, could lead to increasing market share of distributing companies. The increase in Chinese OEMs registering their products on VeraSol is largely observed in SSA-destined products and driven by quality requirements of government and donor-funded OGS programs. For example, the number of Chinese manufacturers with VeraSol-certified products increased to 28 in 2022 from 14 in 2019, surpassing the number of European manufacturers (22 in 2022). Chinese OEMs mostly partner with last mile distributors (LMDs) and specialized OGS companies as well as programs with a focus on increasing participation and efficiency of local based companies. The GET.invest Financial Readiness Support currently being piloted is one such example. This may lead to increased competition and directly affect market share of vertically integrated companies.



Entries in nascent and emerging markets continue to increase due to large market opportunities and increasing government and donor support.













²⁶⁵ Verasol (2021), *Quality in the Off-Grid Solar Market: An Assessment of the Consumer Experience in Kenya*.









²⁶⁶ GOGLA (2021), *Off-grid Solar Supply Chain Disruption: 87% of Manufacturers Expect Increased Prices for Consumers*.

²⁶⁷ UOMA (2021), *The COVID-19 Impact on Access to Finance for Local Off-grid Solar Businesses in Uganda*.

²⁶⁸ Bboxx (2022), *Bboxx Secures \$15 Million Debt Package*; d.light (2021), *Inspired Evolution Led \$15 Million Raise in d.light to Fund Expansion in Key Markets*; d.light (2021), *d.light Welcomes Investment from Proparco on its Journey to Impact 1 Billion Lives*; General Atlantic (2022), *Sun King Raises \$260 Million, Led by General Atlantic's BeyondNetZero, to Expand Global Access to Affordable Solar Energy*.

Figure 52: Key affiliate market competition statistics²⁶⁹

 Market attractiveness	Nascent	Emerging	Mature	Peaked
Total number of companies (2021)	34	61	53	10
Overall increase (decrease) in total number of companies (since 2019)	9 	12 	2 	12 
Total Lantern & MLS sales volumes (2021)	146,532	1,689,041	1,589,324	627,049
% increase (decrease) in Lantern & MLS sales volumes (5-year CAGR)	50% 	12% 	3% 	41% 
Total SHS sales volumes (2021)	50,105	233,645	514,856	12,655
% increase (decrease) in SHS sales volumes (5-year CAGR)	97% 	135% 	109% 	25% 

 Market share of the top three players by sales and changes in sales				
Market share of top three Lantern & MLS players (2021)	47%	60%	89%	100%
Increase (decrease) market share of top three Lantern & MLS companies (2019-2021)	16% 	3% 	5% 	12% 
Market share of top three SHS players (2021)	70%	58%	63%	93%
Increase (decrease) market share of top three SHS companies (2019-2021)	15% 	4% 	5% 	34% 

More companies are entering nascent and emerging markets, attracted by the market potential of thousands of unelectrified households and support programs by governments, development partners and donors. A large percentage of the population in nascent markets lack access to electricity. While higher poverty rates, economic fragility, and insecurity has limited the number of active companies overall, observed market entries are often driven by the market potential of the unelectrified population. For example, with a population of 84 million - of which 91% are unelectrified, DRC presents an attractive market for some OGS companies, exemplified by Bboxx's entry in 2017 and Altech's recent expansion into additional regions of the country.²⁷⁰ The market potential alone is often not compelling enough, and companies at times make their entry/expansion decisions by government and donor commitment to growing the sector through dedicated programs. One vertically integrated company that recently benefited from the provision of a subsidy by Nigeria's Rural Electrification Agency (NREA) was driven by the program's subsidy potential.²⁷¹

Market entrants in nascent markets reporting sales over the last three years are primarily Chinese OEMs. LMDs are the primary route to customers for OGS manufacturers and have previously mainly distributed products of vertically integrated companies. Increased Chinese OEM market entrants indicates that these LMDs are beginning to diversify their product portfolios to include distribution of quality-verified, white label products sourced from Chinese manufacturers. In order to increase their products' attractiveness, Chinese OEM manufacturers are also increasingly including PAYGo technology in their products. For instance, Shenzhen Solar Run and Niwa, two Chinese manufacturers, partnered with Angaza.²⁷² This trend is supported by the fact that the top three players in nascent markets have steadily lost market share over the last three years.

While the majority of sales in nascent markets are still solar lanterns and multi-light systems mostly sold in cash, a steady increase in SHS sales indicates rising demand for, and ability to afford, larger systems. A number of affiliates entered nascent markets by selling

269 GOGLA data from affiliates that reported sales in referenced periods and OCA analysis. Notes: [1] * Market attractiveness: an increase in the total number of companies or in sales volume signals increasing market attractiveness while a decrease signals a decline in market attractiveness, and [2] CAGR stands for Compounded Annual Growth Rate.

270 [Bboxx \(2022\), Country Profile DRC.](#)

271 OCA stakeholder consultations.

272 [Shenzhen Solar-Run \(2022\), Solar Run and Angaza Partner to Bring Reliable Energy Access to Underserved Markets; Niwa \(2022\), Our Partners; Angaza \(2022\), Manufacturers.](#)

solar lanterns and multi-light systems but introduced SHS a year after market entry, leading to a decline in the market share of the top three players. Although increasing SHS sales signal rising consumer energy needs, affordability remains a challenge as many nascent countries have limited PAYGo infrastructure. However, some nascent markets like Mozambique have begun developing mobile money networks through support to enable PAYGo financing, which is expected to lead to increased competition in the SHS segment.

Chinese OEMs working through local distributors and vertically integrated companies opening subsidiaries in new markets has driven competition in emerging markets. This move is largely driven by increasingly attractive enabling environments such as tax and duty relief, increasing mobile money penetration and government subsidies focused on scaling the OGS sector. For example, M-KOPA and Bboxx officially entered the Nigerian market in 2021.²⁷³



Declining entries were observed in mature markets driven by a decreasing commercially viable customer base and already high levels of competition, while exits were noted in peaked markets due to advances of grid electrification.

There are fewer market entries in mature markets, indicating saturation of the commercially viable market. There are already many companies serving mature markets, competing for commercially viable customers. Although the electricity access gap is still significant, at 30% of the population (see Section 5.1), this market segment is less commercially attractive for companies active in the sector, given they are located in hard-to-reach areas and lack the ability to pay for access. As a result, programs such as demand-side subsidies and RBFs, are gaining popularity to incentivize companies to serve these customer segments. For example, KOSAP, an RBF program launched by the Kenyan government, is incentivising companies to enter 14 most unelectrified counties in Kenya. The decreasing market share of the top three affiliates providing SHS products in mature markets indicates an increasingly aware customer base assessing product differences, often based on cost.

A general decline in OGS sales and the number of companies reporting sales serving peaked markets is observed. The decline in the number of affiliates that reported sales in peaked markets was observed in 2019 and 2020, and is potentially due to off-grid solutions taking up a small proportion of some distribution companies' product portfolios and pandemic-related difficulties in 2020. The downward trajectory in OGS sales is in line with the low electricity access gap in peaked markets as the grid expands to electrify a larger proportion of the population. OGS solutions remain relevant to serve those who cannot access the grid, and those with unreliable grid connections. Based on this trend, competition among companies is likely to continue reducing as grid connections are strengthened and companies exit or shift focus to other OGS products, including PUE appliances.

5.2.2 PUE Appliances Market Competition



Competition in the SWP segment remained relatively stable and sales volumes continue to be driven by specialized companies.

Only a few traditionally solar energy kit companies have included SWPs in their product portfolios in mature and emerging markets, though interest in PUE appliances is rising among LMDs. Bboxx and PEG, two companies that previously focused on SEKs are currently offering SWPs as part of their portfolio. They have done so through subsidy programs and partnerships. Other companies have considered incorporating SWPs into their product portfolios to benefit from the potential for increased income, better repayments, and customer segment diversification, but prioritized managing cash flows and adjusting business operations. Other reasons companies have not incorporated SWPs into their portfolios include the difficulties of adjusting business operations to allow for the products' complex sales, installation and maintenance processes. Despite noting similar difficulties, more LMDs are selling PUE appliances and more are interested in doing so in the future driven by rising consumer demand and potential to achieve higher impact. This is evidenced by the fact that 35% of Global Distributor Collective (GDC) members reported sales of PUE technologies in 2022, up from 6% in 2019, with the majority stocking SWPs

²⁷³ [M-KOPA \(2021\), M-KOPA Expands to Nigeria, Appoints Babajide Duroshola as New Country General Manager; Bboxx \(2021\), Bboxx Launches in Nigeria to Deliver Clean Energy and Sustainable Development to 20 Million People.](#)

at 26%. Furthermore, an LMD survey revealed that 21% of respondents would like to sell PUE appliances in the future; this is the product category that registered the highest level of interest.²⁷⁴

Specialized SWP distributors are few and continue to lead B2C sales in the SWP market segment in mature markets in SSA, with financing options being the primary driver of market uptake. Specialized companies create added value to their customer base by bundling SWPs with additional appliances such as TVs and services such as agronomy advisory and weather forecasting. However, affordability remains the biggest barrier to customer uptake of SWPs, with cash prices starting from approximately \$500. As a result, specialized pump distributors, such as SunCulture and Simusolar, continued to drive B2C sales through their PAYGo platforms. Similarly, in a quest to increase its market reach in rural areas, East Africa's leader in pump distribution, Davis & Shirliff, recently signed an agreement to make financing available to its end consumers with the National Bank of Kenya to provide a 5% discount on SWPs financed by a \$40 million loan facility by the bank.²⁷⁵

SWP sales in Bangladesh and India, continue to be driven by government subsidies that are attractive incentives for companies. Agriculture is one of the key contributors of Bangladesh's and India's GDP. Government irrigation programs are strategic moves to strengthen the sector and increase output. Since inception, India's PM-KUSUM scheme has facilitated the installation of over 110,000 solar water pumps (see Box 9) while the Bangladesh government, in partnership with IDCOL, has installed 1,500.²⁷⁶ These programs were launched in 2019 and 2021 respectively. Sales are likely driven by well capitalized companies, given the slow nature of government repayments, which necessitates sufficient working capital to compete for government tenders.



Solar refrigeration saw an increase in competition especially in the cold storage segment, despite the total number of companies in the segment remaining small.

The diversity of companies active in the refrigeration segment in mature and emerging markets has increased, primarily driven by companies targeting the agriculture sector. The greatest potential demand in the cooling industry is driven by the agricultural sector, which has always been an attractive target for cooling appliances due to the perishability of produce and the need to keep produce fresh for both the export and local markets.²⁷⁷ New market entries and expansions for instance include walk-in-cold room companies, like Ecozen, InfiCold and refrigerator companies such as Koolboks and Sundanzer, driven by programs such as IFAD's Green Technologies Program targeting Rwanda, Mozambique, Malawi, Zimbabwe and Tanzania.²⁷⁸ Programs by development partners and donor organizations are already being set up to support scaling of viable business cases for solar cooling technologies across various agriculture value chains. While these programs have assisted in increasing competition in the sector, business models need to be further developed to address product market fit and to start competing in the market (see Section 4.4).

COVID-19 also led to increased supply of cooling solutions to the healthcare sector, with sales likely driven by a few companies and direct procurement from governments and development partners. Increased supply of refrigeration units to the healthcare sector was observed during the pandemic period, particularly of solar fridges for COVID-19 vaccines. This was largely funded by governments and development partners for remote health centers in all markets. For example, in sub-Saharan Africa, SureChill received funding from the Global Environment Facility (GEP) to equip off-grid health centers in Kenya and Eswatini with solar fridges for COVID-19 vaccines, and in SEA, GAVI, the Vaccine Alliance launched an initiative involving the provision of 674 Cold Chain Equipment (CCE) to help boost Papua New Guinea's (PNGs) cold chain capacity for the safe storage of vaccines.²⁷⁹ Only a handful of companies are able to provide these solutions as safe storage of vaccines is ensured by detailed government and WHO requirements for cooling technologies.

274 [The Global Distributors Collective \(2022\), State of the Sector.](#)

275 [Business Daily \(2022\), NBK, Davis & Shirliff Sign Financing Deal for Water, Solar Systems.](#)

276 [Ministry of New and Renewable Energy \(2021\), KUSUM Scheme.](#)

277 [Ecozen \(2021\), Ecozen Comes to Kenya: Channelizing the Path to Sustainable Development.](#)

* Compared to solar lanterns and multi-light systems and SHS, there are no quality verification standards in the SWP segment. VeraSol only tests products and provides recommendations on technical ability.

278 [Efficiency for Access, Lessons Learned from IFAD Green Technologies Project.](#)

279 [UNICEF\(2021\), Government Receives Additional Cold Chain Equipment for Country's Overall Immunization Program; SciDevNet \(2021\), Solar Fridges to Chill COVID-19 Shots in Rural Africa.](#)

5.3 Company Performance and Profitability



The affiliate market has proved resilient in the last two years, in part due to the rise of PAYGo. Some high-performing companies have grown and matured, whereas others have stagnated or shrunk.

The market value of solar lanterns and SHS (including appliances if sold together) from affiliates reached a record \$584 in 2021, up from \$565 million in 2019, and \$525 million in 2020. The rise of PAYGo among affiliates is a hugely significant trend - whilst PAYGo sales represented only 36% of the units sold in 2021, these sales represented more than three quarters of the total market value, exceeding more than \$450 million (Figure 53). Given that the median down payment on a PAYGo product is 8% of the total contract amount (see Section 2.4.1), assessing companies' financial performance requires us to look beyond sales to how successful they are at collecting subsequent payments.

Figure 53: Number and market value of cash sales and PAYGo sales from affiliates²⁸⁰

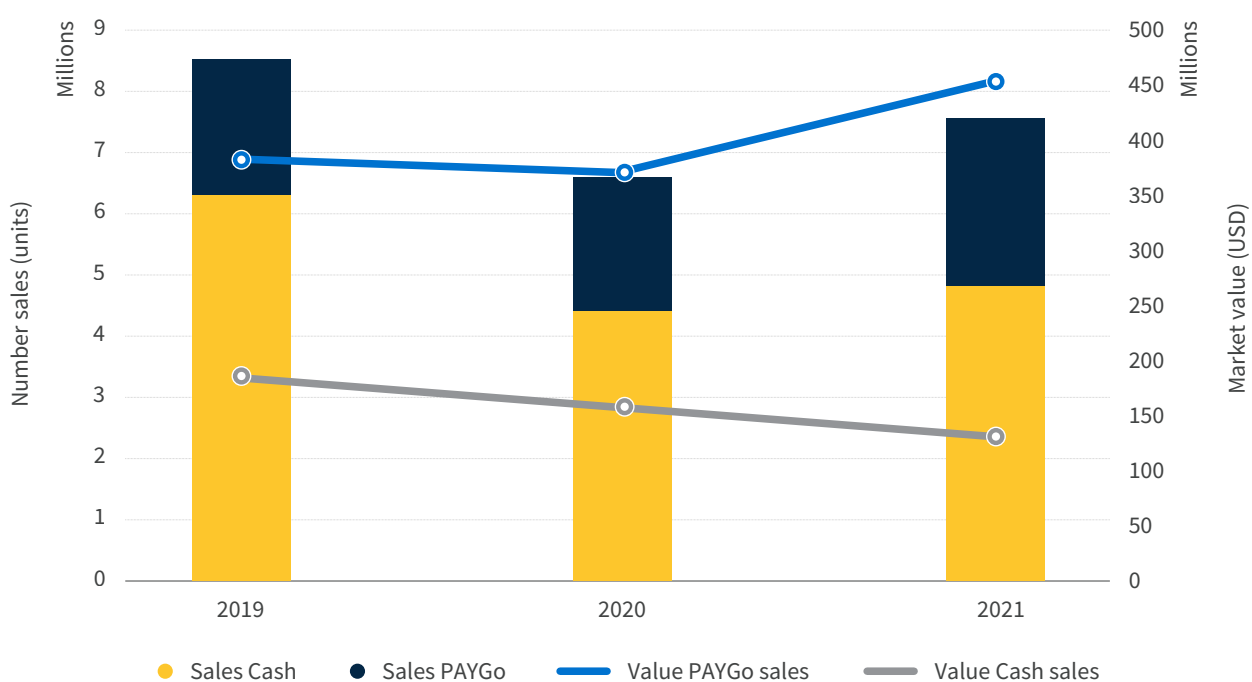

Pioneering market data is now available on key financial and operational metrics of PAYGo SHS players that enables a deeper and richer analysis of company and industry performance.

PAYGo market trends and company benchmarks on portfolio quality and financial health indicators are now available, in what is a new development since the 2020 Market Trends Report. Building on the industry-standard PAYGo PERFORM KPIs that were finalized and published in 2021.²⁸¹ There is now a PAYGo market data initiative with a growing number of PAYGo companies reporting data, and new ways of sharing and analyzing the data coming online. The data can help companies to measure

²⁸⁰ Analysis based on GOGLA Sales & Impact Database. Results are for solar energy kits and appliances (if sold together).

²⁸¹ [CGAP, GOGLA, IFC Lighting Global, MFR \(2021\), PAYGo PERFORM: Financial, Operational, and Portfolio Quality KPIs for the PAYGo Solar Industry.](#)

and benchmark their performance and find areas for improvement, whereas from the investors' perspective, standardized periodic reporting and benchmarking make it easier to assess industry risks and understand the potential for growth and return. Furthermore, it provides donors and governments with critical new insights on such

as how many people default on payments and the financial viability of companies. This development is significant as increased transparency and insights on company and industry performance have long been identified as a critical enabler for increased investment and industry growth.

Box 10: PAYGo market data, a new era of transparency and insights

The PAYGo PERFORM Monitor (PPM) started in early 2022 (building on the PAYGo COVID-19 Impact Monitor in 2020-21²⁸²) to provide benchmarks and market trends on industry KPIs for companies and investors. The initiative will collect, analyze, and share these insights semi-annually on an ongoing basis. Summary reports from the initiative will be publicly available and company benchmarks will be accessible to participating companies and subscribers on the interactive ATLAS platform from MFR.²⁸³ The initiative also works to improve transparency on accounting practices and improve comparability of data.²⁸⁴

PPM has collected data from more than a dozen PAYGo companies representing nearly 40 country operations, selling SHS and appliances, between 2019 and 2021. **Participating companies have a combined portfolio of nearly \$600 million, and represent three quarters of the total B2C sales volumes generated by GOGLA affiliates in 12 countries in sub-Saharan Africa.**²⁸⁵ While this is a significant sample it does not cover a share of the sector, meaning results are illustrative rather than comprehensive.



The industry averages for customer portfolio health KPIs show room for improvement, though there are high-performing companies with good portfolios that offer success stories for lower-performing companies to follow.

The Collection Rate - the percentage of customer payments received compared to payments expected for a given period - had a mean value of 62% in 2021, though some companies performed much better than this, and some much worse (Figure 54).²⁸⁶ Consumers can be segmented as 'fast', 'moderate', and 'slow' payers - a low collection rate indicates a large proportion of slow payers, i.e. people who take a much longer time than expected to complete their payments, though eventually do enjoy free use of their system, when fully paid off. The OGS business model is relatively tolerant of slow payers due to the powerful payment incentive from the lock-out technology, the in-built flexibility and length of the payment plans, and the repossession value of the assets.

Low collection rates are a concern for companies as they put a strain on their financial health. Whilst most companies target and plan for a higher collection rate than the mean of 62%, this figure isn't inherently unviable if it is baked into the business plan. The 15% of PAYGo country firms with collection rates above 80% are likely close to or exceeding targets, whilst the 15% below 40% are undoubtedly well off the mark. The company benchmarks help identify an individual company's performance relative to peers, and the detailed results show the trends by country and region, and company size. Notably, three of the four worst performers on collection rate are in a single country, pointing to the market context such as lockdown measures or other macroeconomic trends driving results, as opposed to company strategy.

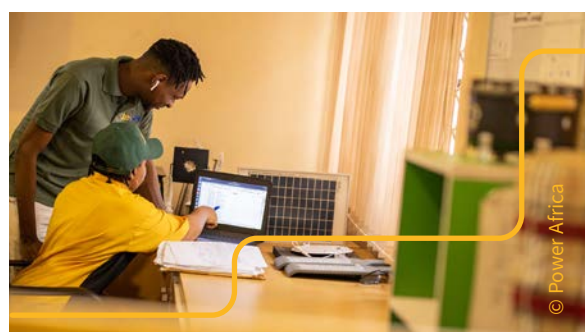

282 [GOGLA \(2022\), PAYGo COVID Impact Monitor Infogram.](#)

283 [Atlas \(2022\), About us.](#)

284 [World Bank/Lighting Global, GOGLA \(2021\), PAYGo Accounting Brief.](#)

285 *The PAYGo business model is predominantly used in sub-Saharan Africa, whilst in South Asia and other large markets, products are more often sold on a cash basis or through microfinance institutions.*

286 *The mean value is non-weighted, i.e. each company weighs the same. The goal is to present the performance of companies, including both small and large (otherwise performance is skewed towards few large companies with many customers).*

Figure 54: A histogram of the median portfolio quality results of PAYGo companies in 2021²⁸⁷

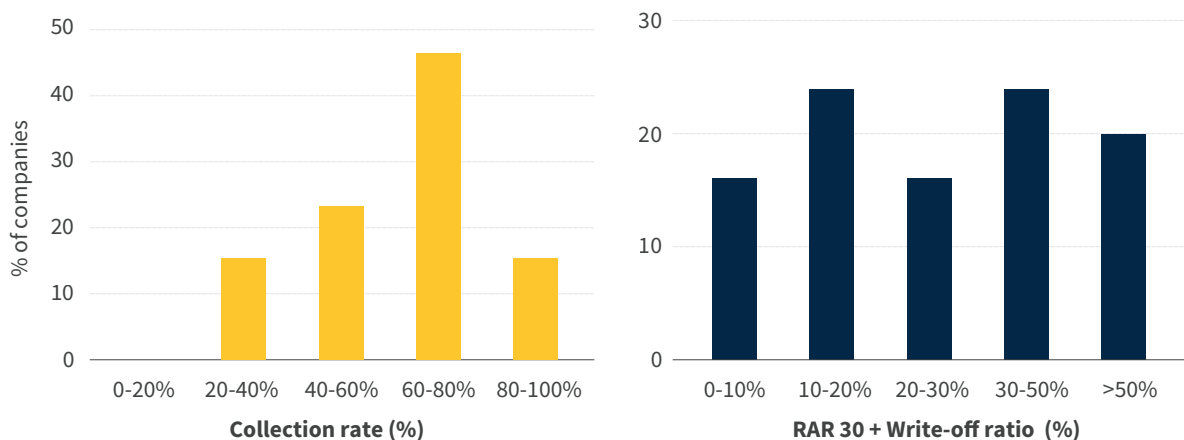

There has been a decline in the portfolio health of the PAYGo sector in 2020 and 2021 that represents a loss of income for PAYGo companies. It suggests that many people may have lost access to electricity.

The mean collection rate dropped from 67% in 2019 to 66% in 2020 and 62% in 2021, and the Write-Off Ratio + RAR 30 indicator (a measure of non- and slow-payments)²⁸⁸ increased from 18%, to 29%, and 32% in the same period (Figure 55). The Write-Off + RAR 30 results worsened for three-fifths of companies between 2020 and 2021, and worryingly, one-fifth of companies have more than half of customers in this category. Simultaneously, two-fifths of companies' Write-Off + RAR 30 results improved between 2020 and 2021, and one-sixth have less than one in ten customers in this category. Overall, this

indicates an increase in the number of customers who lost access to their systems after defaulting on their payments, and presents a significant concern for customer well-being. Even before the pandemic, as many as 5% of people purchasing a SHS,²⁸⁹ and 9% of people purchasing a SWP,²⁹⁰ had to regularly cut back on food consumption in order to afford payments. The pandemic has exacerbated the affordability issue in many places, as in Kenya for example, where food insecurity jumped from 14% pre-COVID-19 to 47% in mid-2021.²⁹¹



²⁸⁷ [GOGLA, World Bank/Lighting Global, MFR \(2022\), PAYGo PERFORM Monitor](#). In partnership with CGAP, CDC, FMO, UNCDF. To ensure the data from different companies is comparable, the data is collected as 'building blocks' rather than the calculated ratios, e.g. it collects payments expected and payments received rather than Collection Rate (since there are a variety of ways companies calculate the Collection Rate). Only country operations older than two years are included to avoid the irregular results of very young portfolios creating 'noise'.

²⁸⁸ Write-Off Ratio: the percentage of payments expected from customers that have been written-off due to customer non-payment during a given period. The Receivables at Risk on 30 consecutive days unpaid (RAR 30) is used alongside the Write-Off ratio to offer more comparable results (since it neutralizes differences in accounting practices arising from variations in when companies record a write-off). Note: Write-offs are removed from the Collection Rate calculation (since they are no longer active customers with expected payments), thus an increase in Write-offs can improve the Collection Rate.

²⁸⁹ [60 Decibels \(2020\), Why Off-Grid Energy Matters. An Impact Performance Report](#).

²⁹⁰ [60 Decibels, Efficiency for Access Coalition \(2021\), Use and Impacts of Solar Water Pumps](#).

²⁹¹ [Central Bank of Kenya \(2022\), FinAccess MSF COVID-19 Tracker Survey Report](#).

Figure 55: Trends in non-weighted mean PAYGo Collection Rate and Write-Off Ratio + RAR 30²⁹²

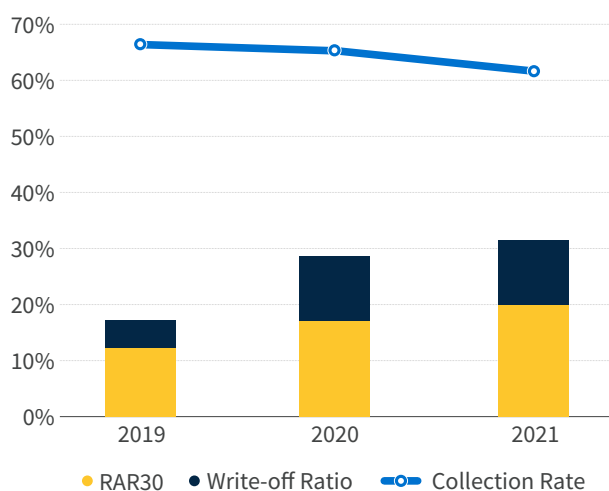

Data suggests that whilst COVID-19 has had a big impact on portfolio health, company performance largely depends on business strategy and execution. There were high levels of variation among company collection rates and Write-Off ratios pre COVID-19. The gap between high-performing and low-performing companies increased

from 2019 to 2021. Companies that had strong credit risk management were better able to cope with the downturn, though there are also other drivers in some cases, for example, impacts affecting particular country contexts or customer segments.



Higher performing companies have strong credit risk management, and consumer protection practices that are underpinned by rich data analytics.

Some companies have highlighted that the low collection rates in more mature markets (such as Kenya) may also be linked to customers buying more than one PAYGo system and ‘picking and choosing’ which they pay for and use at a given time. The establishment of an industry-focused Credit Reference System to help companies assess potential customers’ ability to pay and identify if they are already an existing customer of another provider could be a useful tool for companies, and at the same time help customers to avoid becoming financially overburdened with contractual obligations from multiple providers.

Box 11: Two sides, one coin: credit risk management and consumer protection²⁹³

For PAYGo companies, credit risk management and consumer protection are inseparable. To protect customers, companies need to ensure that they understand the terms of their contract and can comfortably make payments. Equally, if companies want customers to pay for their financed assets, they need to conduct honest and fair business, and ensure they’re satisfied with their product.

Responsible sales and pricing and fair treatment of customers are two of the key Principles within GOGLA’s Consumer Protection Code. These Principles have been developed alongside a framework for companies to measure, monitor, and improve their performance. Independent monitoring and verification is also being piloted.

78 companies and investors have made a Commitment to the Consumer Protection Code and are using it for self assessment and reporting, with 36 having adopted it since January 2020.²⁹⁴ Simultaneously, the standard of knowledge and practice on credit risk management in the industry has improved.²⁹⁵

Whether a product works well, and the ability and speed with which a company resolves issues, are significant factors in consumer satisfaction. The Net Promoter Score in the industry is high, with an average of 67 for solar lantern owners, 47 for SHS owners, and 38 for appliance

owners.²⁹⁶ Even still, among the top performers there is room for improvement with around one third of their customers experiencing a technical challenge with their product or payment, and only about a third of these cases are fully resolved.²⁹⁷ Furthermore, there is a correlation

292 [GOGLA, World Bank/Lighting Global, MFR \(2022\), PAYGo PERFORM Monitor.](#)

293 [CGAP \(2021\), Two Sides, One Coin: Credit Risk Management and Consumer Protection.](#)

294 [GOGLA \(2022\), Consumer Protection.](#)

295 [CGAP \(2021\), Getting Repaid in Asset Finance: A Guide to Managing Credit Risk.](#)

296 [60 Decibels \(2020\), Why Off-Grid Energy Matters. An Impact Performance Report.](#) Note: the creators of the NPS suggest that a score above 0 is good, above 20 is favorable, above 50 is excellent, and above 80 is world class.

297 [GOGLA, 60 Decibels \(2020\), Consumer Insights during COVID-19.](#)



between customers that reported that the payments are a higher burden, and low satisfaction and payment rates (Figure 56). The customers that are too stretched to make payments and have to spend periods with the system being locked are naturally less satisfied. High-performing companies achieve the virtuous cycle of providing customers with a payment plan they can afford, delivering good-quality products and service, and reaping higher payment rates.

The top-performing companies have very high consumer satisfaction rates, though there is a wide variation between companies. This is driven by product quality, after-sales service, and low burden of payments, and correlates strongly with payment rates.

Figure 56: Consumer experience and satisfaction ratings for 15 PAYGo SHS companies²⁹⁸

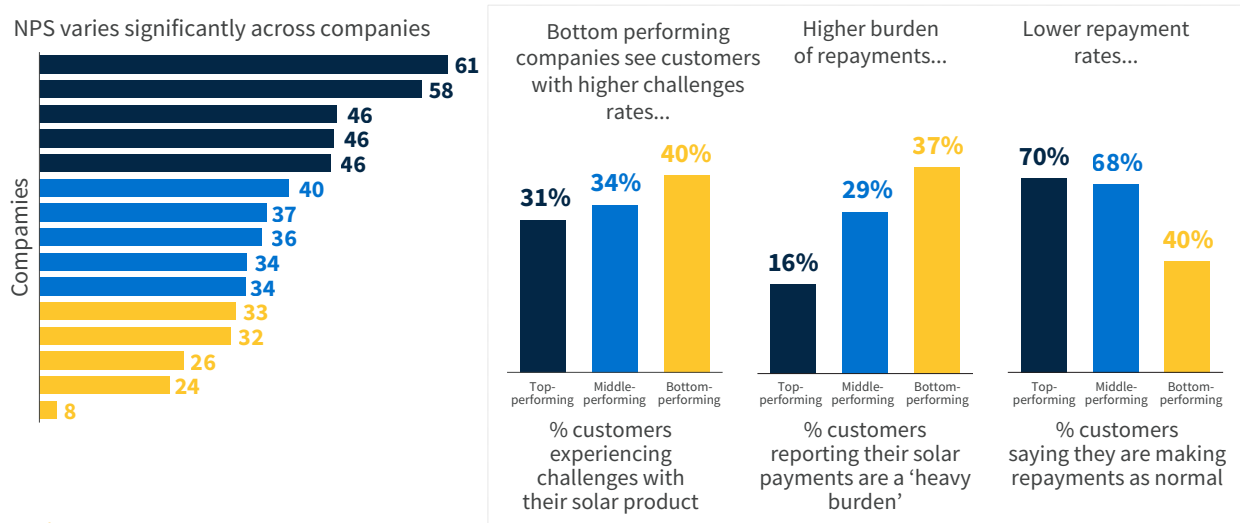

The performance of productive use companies largely depends on the ability of their customers (i.e. entrepreneurs or smallholder farmers) to grow their incomes, and this requires the PUE company to provide services beyond the technology.

Research on productive use machinery in agriculture shows that more often than not, economic factors that hurt the ability of the entrepreneur to make additional revenue are the main factor that undermines ability to pay and Collection Rates.²⁹⁹ Even if the solar-powered

technology works perfectly, if the farmer, for example, doesn't have the knowledge or inputs to increase production, or lacks access to the market to sell the produce at a good price, there may not be sufficient increase in income to pay for the system. Successful productive use companies are providing an end-to-end service that aims to ensure customers have the knowledge, information, and support they need to raise incomes and make payments (see section 5.4).

A recent study showed most companies achieve gross margins - a measure of the product price and indication of company profitability - in the 45-55% range, though the leaders sustained a gross margin of ~60%+.³⁰⁰ It estimates that 55+% is needed to be profitable at scale and generate enough cash to cover the high operating costs of serving low-income consumers in distributed geographies with the high costs of finance currently available to the industry. However, PAYGo players face the dilemma that if they increase their prices to improve their financial health, their products may

²⁹⁸ [GOGLA, 60 Decibels \(2020\), Consumer Insights during COVID-19 Webinar.](#)

²⁹⁹ [A2EI \(2021\), Productive Use Machinery in Agriculture, from Development to Market Maturity.](#)

³⁰⁰ [Persistent \(2021\), Learnings from a Decade of Investing in Energy Access in Africa.](#) Gross Margin is defined as: (Contract Value - Cost of Good Sold) / Contract Value. The Gross Margin does not include Operating Costs such as staff, facilities, provision for loss, cost of finance, overheads, etc.

become unaffordable to their target customers and make it harder to reach sales and impact targets.



Industry discourse on strategy has now firmly moved to ‘quality over quantity.’ As the sector matures, companies and investors are driving for strong unit economics over a fast growth and scale strategy. This will help drive industry sustainability and growth.

The alternative is to reduce costs, though this has proved harder to achieve. High sales volumes can help achieve economies of scale that reduces the cost of goods

sold and boosts the gross margin. However, the study asserts that whilst a certain scale is required to achieve profitability, having strong unit economics is the key determinant of profitability rather than size. Running a lean operation and adjusting the operating model to work in the local context is considered paramount.

Another study of 15 last mile distributors (LMDs) showed that locally-owned companies are leaner and more efficient (Table 2). They have a significantly higher ratio of total sales revenue to total capital raised, an alternative measure of the financial performance, than foreign-owned companies. This indicates they are much leaner probably due to value chain specialization, local market knowledge, and low overheads, and therefore may have a shorter path to profitability.³⁰¹ However, the low ratio of the foreign-owned companies may be a feature of their stage of maturity - achieving a higher ratio may take longer as they have invested more heavily in organizational development and expansion and are yet to achieve economies of scale.

Table 2: Slower-growth and locally-owned LMDs have realized higher revenues per \$ of capital raised than faster-growth and foreign-owned LMDs. Data from 15 LMDs selling off-grid solar products³⁰²

	Total sales revenue	Total capital raised	Revenue / Capital Raised ratio
Faster-growth (7 LMDs)	\$63 million	\$33 million	1.9
Slower-growth (8 LMDs)	\$21 million	\$10 million	2.2
Foreign-owned (8 LMDs)	\$50 million	\$34 million	1.4
Locally-owned (7 LMDs)	\$34 million	\$8 million	4.1

Nearly one-third of country firms (29%) reported a positive EBT margin (cashflow)³⁰³ to the PAYGo PERFORM Monitor in 2021, and many of these firms are on a positive upward trend from 2019 and 2020. Companies reporting profitability have established strong portfolio quality and unit economics, as well as a variety of other strategies that are elaborated in Section 5.4. The profitability of industry leaders represents a significant

new development as it is a potential tipping point to unlock long-term growth and sustainability for the sector. Sun King’s recent series D equity round of \$260 million, and d.light’s \$238 million debt raise in 2022, and other scale-ups exploring an initial public offering (IPO) points to a step-change in the ability of market leaders to access new sources of capital on the back of strong financial performance (see Section 8 Funding Flows).

³⁰¹ *Global Distributors Collective (2021), The Growth and Fundraising Journeys of Last Mile Distributors (LMDs). The 15 LMDs selling off-grid solar products are between 4 - 12 years old and at different stages of maturity. Faster-growth LMDs have an increase in annual revenue greater than \$440k per year (though results have wide variation). Locally-owned is defined as majority local ownership and leadership. Note: there is significant overlap between LMDs classified as faster-growth and foreign-owned, and smaller-growth and locally-owned, though not a complete match. 67% of the faster-growth companies have ambitions of market leadership, rapid scale and/or international expansion, whereas 67% of the slower-growth companies pursue consolidation in existing markets and profitability before expansion.*

³⁰² *Ibid.*

³⁰³ *Profitability remains a challenging characteristic to define and measure in the off-grid solar industry due to the complex business models, variety of metrics, and different accounting methods. The PAYGo PERFORM initiative concluded that EBT Margin (on cashflow) is the most meaningful and comparable single metric for profitability, though Contribution Margin (on cashflow) may be more useful for young companies despite it being more difficult to calculate. For companies with multiple countries of operation, milestones of profitability include positive EBT margin (cashflow) in each country and then at the group level (with other business units such as manufacturing and software further complicating the picture for vertically integrated players).*



A handful of off-grid solar companies now report being fully profitable, whilst others report being partly profitable. This has enabled some market leaders to unlock a wave of investment from a new, later-stage, commercial investor base.

However, many companies in the industry have further to go on the path to profitability. A survey of GOGLA's members in early 2022 revealed that 25% of respondents reported being profitable using net profit (including cost of goods sold, operating expenses, cost of financing, and taxation), a further 13% were profitable using operating profit (which excluded the cost of financing and taxation).³⁰⁴ This left the majority of respondents, 53%, reporting that they made a gross profit, excluding operating expenses, and a further 9% were not profitable, failing to cover the cost of goods sold.

The reduced purchasing power of consumers and increase in costs over the last two years has been a setback for many companies on the path to profitability, though despite this respondents were almost universally optimistic about their prospects going forward, with 97% expecting their financial sustainability to improve in the next three years. Realizing the full potential of the off-grid solar industry will be dependent on whether a wider range of companies are able to improve credit policies and practices, and better manage the challenges of servicing a large number of low-income customers, dispersed across wide geographies and difficult economies.

It is difficult to characterize the profitability of the productive use segment given the early stage of the market, the range and diversity of technologies and business models, and the lack of data and insights. There are a number of mature companies that have been selling productive use technologies for many years (e.g. Davis & Shirtliff), and PAYGo specialists that are emerging strongly (e.g. SunCulture), though many players are still too young to achieve profitability. Segment leaders have established strong product unit economics, but profitability will require greater scale for these capex intensive businesses

³⁰⁴ GOGLA (2022), *Financial Sustainability Survey (unpublished)*. The survey included responses from 38 companies, predominantly distributors and manufacturers, mostly under six years old, with a smaller proportion between 7 and 12 and over 12 years old. The majority of respondents operated in just one country, with smaller proportions operating in 2-5 or over 6 countries. The survey was conducted before the outset of the Ukraine war, which as we know has changed the outlook on the global economy.

³⁰⁵ *Liquidity (next 90 days/Total Costs)*. This is an indicator of how easily a company is able to pay its financial liabilities e.g. through cash reserves or assets that can be quickly liquidated.

³⁰⁶ CGAP (2020), *Is There a Liquidity Crisis Among MFIs, and if so, Where?*

³⁰⁷ *NextBillion (2022), Understanding COVID-19's Impact on PAYGo Solar: Data From a Pioneering Study Reveals Key Insights About the Sector's Financial Sustainability*.

with large fixed costs. As per the collection rate (described above), a strong financial performance requires that the company address many challenges faced by their customers in what becomes a complex operation.



Many companies have struggled in the face of the pandemic due to rising costs, reduced customer incomes and a more challenging investment environment. This has led some companies to exit the market.

Whilst the sector did not experience a widespread liquidity crunch as was feared in early 2020, and some companies report healthy reserves, it appears many companies are in a weak cash position. Data from 26 company country operations in the PAYGo PERFORM Monitor showed that the median liquidity rate (the availability of liquid assets over 90 days) increased from 34% in 2020 to 44% in 2021.³⁰⁵ This shows a promising move in the right direction, but figures remain low in absolute terms and need to increase further if these players are to increase resilience. There are a notable few company operations that report a much healthier position with figures well over 100% due to recent investments, prudent cash conservation, and strong financial and operational performance. The MFI sector provides a useful comparison; 86% of MFIs can cover more than three months operating expenditure with cash in hand (equivalent to a 100% liquidity value of 90 days), and many hold considerably more.³⁰⁶ Achieving these industry averages in the PAYGo solar market will be highly dependent on the future investment landscape and companies' ability to control costs and move towards profitability.³⁰⁷

Companies with insufficient cash positions pre-pandemic experienced cash flow shortages, with some forced to shut down. Some start-up companies, already over-leveraged, continue to find it difficult to raise capital,

especially equity; debt providers also steered clear, as default risk seemed high.³⁰⁸ Some companies have faced financial difficulties due to a high cost structure and cash burn rate, which creates a pressing need for the leadership team to focus heavily on fundraising, sometimes at the expense of operational excellence. This struggle resulted in a number of companies closing shop during the pandemic.

For example, approximately 13% of Global Distributors Collective's (GDC) members in 2019/20 faced company closures driven by COVID-19-related business disruptions, lack of funding, or inability to stay competitive amidst pre-existing challenges in the business environment.³⁰⁹ GOGLA also reported three COVID-19 related departures from the

market. The experience of Pawame provides an illustrative case study, demonstrating the challenges of managing and fundraising for a PAYGo business that relies on a complex balance of investment and a vulnerable receivables book (see Box 12). Whilst the Energy Access Relief Fund³¹⁰ has been a life-saver for some companies, the disbursements starting in the second half of 2021 arrived too late for others. With the global economic outlook remaining difficult and supply chains still under stress, market entries and re-entries will be limited, and more market exits are anticipated in the immediate future, paving the way for acquisitions.

Box 12: Pawame's struggles through COVID

Pawame is a PAYGo company in Kenya with a specialized distribution business model that leverages the investments in hardware and software of the vertically-integrated early movers. This model holds promise of a shorter path to profitability as the business is simpler and with lower costs relative to the more complex vertically integrated model.

The company was performing well pre-COVID-19, with strong growth, positive operating profit and imminent launch of Series A fundraising. The equity raise was put on hold as the COVID-19 pandemic emerged and debt became hard to secure which led to a shortage of working capital to buy stock and generate revenue. At the same time, the Kenyan economy took a hit with many households struggling financially, resulting in delayed or non-payment from their customer base.

They found a mix of solutions in early 2021 by combining bridge equity funding, debt from the Energy Access Relief Fund and other pandemic-linked debt, and a limited repayment freeze from lenders - although this proved time and labor intensive. Unfortunately, difficulties re-emerged when Pawame's debt-equity ratio, which had deteriorated in 2020, prevented access to new working capital facilities, and a promising Series A equity investor pulled out due to an internal reorganization. At the time of writing, the company had missed debt repayments and their cash runway was shortening.

Pawame is exploring solutions to ensure their customers can continue to benefit from their SHS and their debtors can get a return.

³⁰⁸ *Open Capital Advisors and GOGLA consultations.*

³⁰⁹ *Global Distributors Collective (2022), Last Mile Distribution: State of the Sector; Key to note is that only 75% of GDC members were OGS companies.*

³¹⁰ *SIMA Funds (2022), Energy Access Relief Fund (EARF).*

5.4 Key Trends and Innovations Affecting Competition in the Sector



Achieving profitability remains a key driver for companies in the off-grid solar industry, spurring trends on cost cutting, and increasing sales volumes and customer segment diversification.

COVID-19 has increased the pressure on companies to improve their cash flow management and implement clear paths to profitability. Continued pressure for OGS companies to achieve profitability was noted as a trend in 2020 and has been heightened by the effects of COVID-19. The push for profitability can be observed across different company categories across the OGS sector. This has stressed the importance of companies implementing clear strategies tied to product market fit, business model suitability, and credit management.³¹¹ To reach profitability, some companies have diversified customer segments, increasing their sales to customers with more stable income sources in (often grid-connected) urban areas to de-risk their loan portfolio health, which might lead to slowing SDG7 progress. Many PUE companies are largely on a quest to prove concepts of business models introduced to increase affordability of PUE appliances and create more value for their customers, which is expected to continue to drive PUE demand.



To cut costs and optimize business models, companies continue to outsource niche, non-strategic functions and digitalize operations.

Specialized service providers targeting the OGS sector are slowly emerging in more mature markets. A few years ago, the market trended away from vertically integrated companies into specialized OGS companies focusing on a few segments of the value chain (e.g., distribution and financing), allowing for more partnerships across the OGS sector (e.g. vertically integrated companies, doing both manufacturing and distribution like d.light and GLP expanded their B2B business by partnering with distributors like PEG and Deevabits Green Energy in certain markets).

As the next step in market maturity, we now see a rise in non-OGS companies providing specialized services to the sector, such as after-sales services and payment collection. This trend, seen primarily in more mature markets, is allowing OGS companies to increase their operational efficiency and focus on growing core business functions. For example, in 2020, GLP in India outsourced after-sales services, such as installation, repair and maintenance to CarlCare, a company providing outsourced repair services to mobile phone companies like TECNO.³¹² Given CarlCare's presence in a number of countries in sub-Saharan Africa and Southeast Asia, this service will likely become available in other markets.

Payment collection providers are also among specialized service providers targeting the OGS sector, with some companies already benefiting from their expertise. PAYGo companies traditionally leveraged sales agents to collect payments. While this can be useful to align agent incentives and ensure higher repayments upfront, it often takes a long time to collect all payments. The longer loans remain outstanding, the harder it is to collect partial or full amounts, and the more the resources required for follow-ups. This becomes a costly endeavor, diverting resources away from new sales or other areas of operations. Specialized payment collection companies, such as Glichery Limited in Kenya, facilitate the collection of these payments, allowing OGS companies to outsource this service and keep their businesses lean.

Use of digital platforms continues to be a key trend across OGS companies, to increase efficiency, track performance and reduce costs, and was accelerated due to restrictions in movement during the COVID-19 pandemic. Data and digital tools underpin all aspects of the OGS business and are important in achieving financial and operational success across many business functions and services. While vertically integrated companies, especially those selling PAYGo-enabled products, have already digitized some core functions, such as payment tracking and remote after-sales services,

³¹¹ [World Bank, IFC, GOGLA \(2020\), Off-Grid Solar Market Trends Report 2020.](#)

³¹² [CarlCare \(2020\), CarlCare Becomes Authorized Service Provider for Sun King.](#)

new developments, such as active utilization of big data analytics, are emerging.

Big data analytics is used by OGS players to convert collected data into actionable insights that can be used to more accurately inform business strategies in a timely manner, and to automate and optimize business processes for increased efficiency. Bboxx, for example, launched Bboxx PULSE in 2018, allowing the company to make pre-emptive data-driven decisions. Bboxx has also automated many repetitive tasks like sales lead management and assigning customer care jobs to its operations team to improve efficiency.³¹³ Limited movement during the pandemic also pushed companies to optimize after-sales services through digitalization. For instance, Zonful Energy in Zimbabwe launched a platform digitalizing after-sales service by connecting customers in need of after-sales care to the nearest technician.³¹⁴

While some vertically-integrated companies have the tools and in-house teams to support greater digitalization, many LMDs tend to outsource to specialized digital solution providers. GDC Digital Service Catalog lists over 70 digital services that LMDs can outsource.³¹⁵ The GDC also receives and shares feedback from a series of pilots initiated by its members and digital service providers to drive digital innovation, including a group lending mobile app, a remote sales team management software, and a data driven underwriting service, further demonstrating the opportunity for digitalization to enhance LMD performance.

Outsourcing digital activities has proven beneficial for LMDs, resulting in optimized processes and financial gains. For example, PaygOps, a software solutions provider, reports that one of its clients, an LMD based in Uganda, was able to reduce its operational costs by 85% following adoption of PaygOps' inventory management solution.³¹⁶ These outsourced digital platforms and services are expected to provide a lever for LMDs to level the playing field and increase their competitive edge by improving the efficiency of their business operations going forward.

In the large-scale cooling space, operators introduced Cooling-as-a-Service (CaaS) models to improve affordability of PUE appliance use. Cooling solutions tend to be more cost-effective at scale and are often unaffordable for outright purchase to a large segment of the population. To address the affordability constraint, some companies are exploring the CaaS business model, whereby target customers like farmers and traders can

store crates of produce in part of a cold room at a fixed daily rate charged per crate, improving their ability to afford cold storage in a way that makes sense for their business models.



Improving affordability of PUE products through pay-for-use models is an ongoing trend, with PUE asset financing potentially leading to improved loan repayments.

Large-scale cooling companies are also extending add-on services to increase income generating potential for end users and boost demand for PUE appliance services. Another innovative solution being explored, complementary to the cold storage service and in line with increasing end-user income, is extending services vertically along end-consumer value chains, either downstream (by providing digital market linkage services for agricultural produce) or midstream (by introducing refrigerated trucks to bridge the cold-chain gap). This strategy adds value to consumers, encouraging them to take up cooling services that help increase their income in the long run (see Box 13).



³¹³ [Bboxx \(2018\), Launch of Bboxx Pulse.](#)

³¹⁴ [Global Distributors Collective \(2022\), State of the Sector.](#)

³¹⁵ [Global Distributors Collective \(2022\), Digital Service Catalog.](#)

³¹⁶ [Global Distributors Collective \(2020\), Innovation Challenge.](#)

Box 13: Enhancing cold storage models to increase value to end-users and drive PUE demand³¹⁷

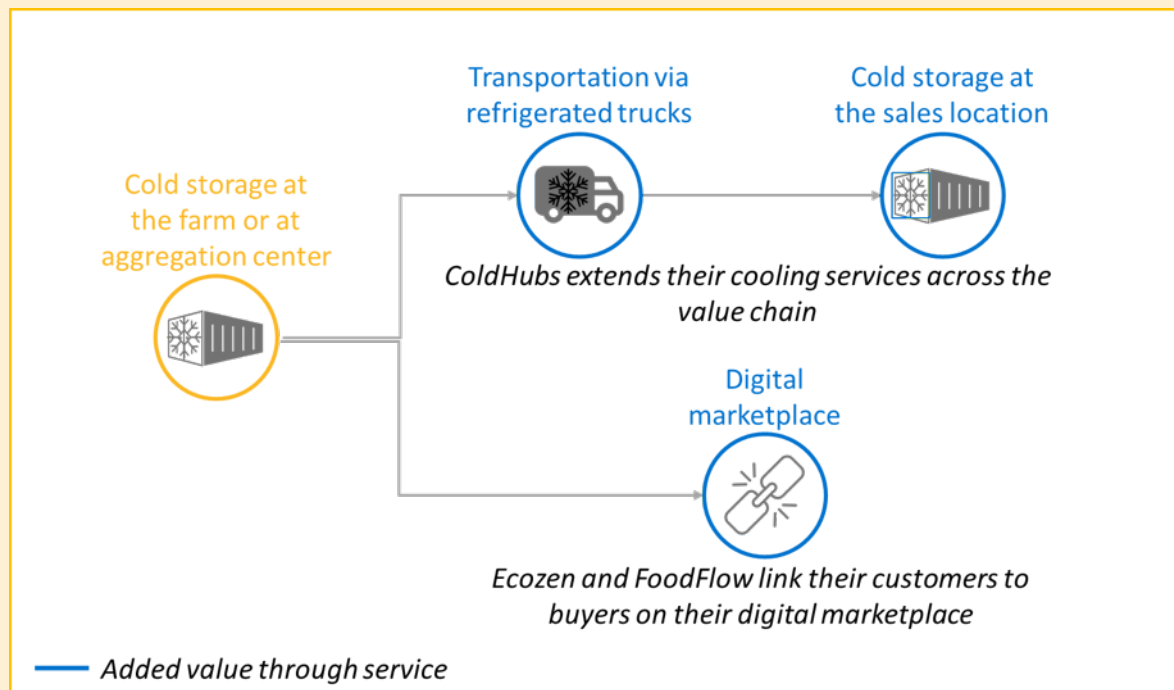

Companies in the large-scale cooling space have started to extend their services beyond localized cold rooms to ensure cooling along customer value chains to drive uptake. As one of the leading providers of affordable, shared cooling services in Nigeria, ColdHubs noted that while uptake of their cold storage services was picking up as they created awareness among their key target customers (i.e., farmers, aggregators, and retailers in the agriculture sector), the uptake rate was not as high as expected. Customers demanded a mid-stream link to ensure that their produce remained fresh at all stages of the value chain. To address this, ColdHubs introduced refrigerated trucks into their model to complete the ‘cold chain’, extending their services beyond stationary cold rooms.³¹⁸ This competitive strategy improves their value proposition to customers and increases demand for their services.

To respond to the market-need, Ecozen in India launched a digital marketplace for farmers to complement their cold storage solutions and SWPs.³¹⁹ Providing a market linkage service for their customers has the potential to improve their returns as customers are able to sell more of their produce and then see more value in investing in cold storage solutions.³²⁰ Such end-to-end services give these companies a competitive advantage in their markets by creating value for their clients and, in doing so, driving demand.

FoodFlow, a food loss-reduction program by Enviu, uses large cold rooms supplied by Ecozen, to offer CaaS to farmers and aggregators in Kenya through its cold storage platform, SokoFresh. The cold storage service integrates a digital logistics function that ensures efficiency in aggregation of agricultural produce and provides smart market linkages to wholesalers and retailers in major cities. The program’s approach reduces post-harvest losses and costs incurred by a single farmer. This makes cold storage affordable and valuable to users who are additionally assured of a market for their produce thus driving overall demand.³²¹

³¹⁷ *Open Capital Advisors analysis.*

³¹⁸ [ColdHubs \(2022\), ColdHubs Unveils Full-scale Refrigerated Transportation Services.](#)

³¹⁹ [Ag. Funder News \(2019\), India’s Ecozen Closes Series A on \\$6m to Help Farmers Reduce Spoilage, Navigate Supply Chain.](#)

³²⁰ [Hindustan Times \(2021\), Startup Mantra: Green Marriage of Farming and Tech Fertilized by Innovative Marketplace.](#)

³²¹ [ENVIU FoodFlow \(2022\), Our Ventures.](#)

The development of more innovative solutions is likely contributing to increased affordability and income of end-users, as well as healthier loan portfolios of PUE companies. The uptake and utilization of PUE appliances can be transformative from an income generating perspective. SWPs and cooling solutions are key in agricultural markets where product volumes and post-harvest losses are concerns for farmers. Farmers who utilize these appliances are able to not only increase their volumes and postharvest output but also raise their income potential as PUE appliances contribute to increased farm yields (solar water pumps) and product longevity (cooling solutions).³²² Increased income potential for target customers increases their ability to fully pay for appliances, which in turn is expected to benefit PUE companies. As a result OGS companies that offer PAYGo are likely able to build healthy loan portfolios as consumers' incomes increase and are able to pay-off their loans. This cycle supports company longevity.



Some companies continue to diversify their product portfolios to reach more profitable customer segments to stabilize their cash flows.

OGS companies across different markets continue to move 'beyond energy' to diversify their income streams. More companies are selling non-OGS or complementary products and services, mostly those they can easily incorporate into their business models, such as smartphones, and LPG gas, as well as education loans, insurance, agricultural advice and crop-price monitoring. For example, d.light began selling smartphones on PAYGo, M-KOPA offers financial services, and Vitalite, a local OGS company in Zambia, partnered with an insurance agency to pilot an innovative agriculture insurance product for SHS customers that provides smallholder farmers in Zambia a 'payment holiday' on their SHS in the case of a severe drought.³²³

This trend is also emerging among LMDs, i.e. 68% of GDC members are selling more than one category of products. Broadening product portfolios can enable OGS companies to reach new, often more urban customer segments, characterized by more stable incomes.

Additionally, providing financing for products with lower overall costs increases the ability of consumers to complete their payments faster, improving cash reserves.

Companies will likely continue diversifying their revenues to remain competitive. Diversifying the customer portfolio to include more urban based, wealthy customers is expected to slow OGS supply to unelectrified, hard-to-reach customer segments. While this might be beneficial for companies in terms of achieving profitability and cash flow stability, and maintaining a competitive edge key to their survival in the market, it may be detrimental to electricity access. Consumers lacking access to energy run the risk of remaining largely unserved, which will negatively affect achievement of SDG7 in the medium to long term.



Despite the push towards product diversification, some companies continue to innovate their business models to serve last mile consumers without electricity access.

Some companies continue to innovate their business models to improve affordability for solar lanterns and multi-light systems and SHS products. Affordability of OGS products remains a barrier. Some OGS companies have leveraged existing business models or innovated new ones to address the affordability challenge, to continue to serve the BoP. For example, GLP extended its offering to PAYGo-enabled solar lanterns and multi-light systems, increasing affordability of existing products further and companies like Mobile Power, and Jaza have launched battery rental businesses, enabling consumers access to solar batteries for a short time period at low rates (see Box 14). Business model innovations like this enabled customers who cannot afford to purchase SHS on PAYGo, to have access to electricity and increased the affordability of solar power for low-income consumers. Innovations like these thus indicate avenues for OGS companies to continue competing in customer segments that are still considered difficult to serve.³²⁴

322 [60 Decibels \(2020\), Why Off-Grid Energy Matters. An Impact Performance Report.](#)

323 [Shell Foundation \(2021\), How can Agri-insurance Reduce the Risk Associated with Solar PayGo?](#)

324 [Shell Foundation \(2022\), Lighting Tanzania's Rural Areas: How Jaza Are Reaching Households Living On \\$2/Day.](#)

Box 14: Rent-To-Rent; an innovative business model for BoP customers

In Tanzania, more than 60% of the population lacks access to electricity, the majority residing in rural areas. Nearly 50% of people live on \$1.90 daily or less (below the extreme poverty line) as of 2018.³²⁵ The limited income makes it difficult for these consumers to afford higher Tier energy options. Recognizing this challenge Jaza Energy, an LMD in Tanzania that offers rechargeable battery packs for household electricity needs on a rental basis, further innovated their business model.³²⁶

Initially, the majority of the target low-income market remained unserved as they were unable to afford Jaza's pricing that included a comparably high initial down-payment. Jaza redesigned its pricing model to rent out its battery pack, with customers paying a small nominal registration fee and providing a guarantor.

The company also opted for lower-capacity batteries of 60Wh to make the model even more affordable.³²⁷ Their fees are now as low as \$1 for registration and \$0.22 for daily rental fees, making Jaza's solution cheaper than kerosene and affordable for people living below the poverty line.³²⁸ Offering its products on a rental basis has allowed Jaza to reach more consumers, providing access to solar power solutions, especially the very poor. To date, the company's innovative business model has seen them reach over 51,000 people across Tanzania, up from 39,000 in 2020.³²⁹

While business model innovations are a key contributor to increasing the competitive edge of OGS companies, establishing innovative business models particularly around increasing affordability tend to be costly. This is due to the capital intensity of launching and sustaining these models, especially where credit mechanisms are required as they increase the number of transactions made for the sale of one system and thus the cost of selling the system. Thus the lower the total value of the product the lower the profit margin tends to be. Companies already have tight margins, making it difficult to commit financial resources to pilot innovative business and operational

models. As such, grant funding is key in providing companies with the support they need to continue to innovate and find the best products and business models to cater to customers at different income levels.

For example, in 2020, Ashden Clean Cooling Collaborative and ClimateWorks foundation launched the Fair Cooling Fund, focused on enabling affordable access to refrigeration solutions for low-income households through provision of grant funding. The fund enabled PEG Africa to pilot the sale and leasing of solar-powered freezers to rural off-grid households in Ghana through facilitating the provision of affordable payment plans.³³⁰



325 [The World Bank, Access to electricity \(% of population\) - Tanzania; The World Bank \(2020\), The World Bank in Tanzania: Overview; The World Bank \(2021\), Poverty & Equity Brief, Sub-Saharan Africa: Tanzania](#)

326 [Jaza Energy \(2022\), Our Products: Packs](#)

327 [EEP Africa \(2021\), Putting Stars on the Map, The Innovative Business Model: Jaza Energy](#)

328 [ESI Africa \(2021\), Tanzania: Supercharging Last Mile Access through Battery Rental; The World Bank \(2020\), Poverty & Equity Brief, Sub-Saharan Africa: Tanzania](#)

329 [Jaza Energy \(2022\), Our Products: Hubs](#)

330 [Ashden Climate Solutions in Action \(2022\), Fair Cooling Fund; Ashden Climate Solutions in Action \(2022\), PEG Africa.](#)





06

Technological
Innovations

KEY MESSAGES

- Off-grid solar technology is now more powerful and versatile. It allows people to leapfrog electrical grids and fossil-fuel sources entirely with quickly-deployable, affordable, low-carbon technology
- ‘PAYGo everything’ is here. PAYGo technology is being leveraged to offer consumer finance on smartphones, electric motorbikes, and many other devices, as well as to offer digital financial services
- There have been rapid advancements in the maturity of a few appliances and productive use technologies, but more R&D investment is needed to accelerate a wider array of technology onto the market
- Distributed solar and storage technologies combined with high efficiency appliances could transform electricity access for homes and businesses on the weak grid

6.1 Developments in the Core OGS Technology



Solar lanterns and solar home systems sold with TVs, fans, and radios are now mature, commercial technologies that offer a high-quality and impactful service for consumers.

As the off-grid industry counts more than 12 years of development, it has a strong core of products and brands that have reached maturity. The historic global product sales by affiliates of solar lanterns, multi-light systems, and solar home systems are 36 million, 7.4 million, and 6.5 million, respectively.³³¹ There were 261 quality-verified solar lanterns and SHS from 67 brands listed by VeraSol in 2021, up from 201 products from 51 brands in 2019. SHS are increasingly sold with appliances, for which there is also a sizable market of quality-tested products on the market, including 152 TVs from 88 brands, 131 fans from 86 brands, and 94 fridges from 52 brands.

Solar energy kit customers appreciate the quality and reliability of the technology, though there is scope to further improve. 75% of solar lantern owners, and 74% of SHS owners, and 66% of appliance owners rated the value for money of their product as ‘very good’ or ‘good’, and the Net Promoter Score is 67, 47, and 38 respectively.³³² However, nearly one third of customers report experiencing a challenge with their product, with the battery being the most common problem. In a move to improve battery performance, the industry has now largely shifted from lead-acid to lithium-ion batteries. Lithium battery technology continues to improve in terms of cycle life/longevity, depth of discharge, energy density, and performance in different environments.³³³ The typical design life for a SEK battery is now around 2500 cycles³³⁴ – potentially giving five to seven years’ service - and this chemistry is also non-toxic which reduces the risks at end-of-life.

The industry has leveraged the rapid decline in costs of solar PV and lithium batteries³³⁵ combined with major efficiency gains for lights to lower prices for off-grid solar consumers. The improvements in appliance efficiency and growing economies of scale have lowered costs for larger and more desirable appliances. TVs have been at the forefront of this trend, with more than 1.5 million units sold by affiliates the majority of which are packaged with a SHS and sold through PAYGo. For example, extra-large TVs saw a 48% increase in efficiency between 2016 and 2019, and a reduction in average cost from \$256 in products tested before pre -2018 compared to \$190 in the 2018–2020 sample.³³⁶

331 *GOGLA analysis based on the Sales & Impact Database.*

332 [60 Decibels \(2020\), Why Off-Grid Energy Matters. An Impact Performance Report.](#)

333 [World Economic Forum \(2021\), Closing the Loop on Energy Access in Africa.](#)

334 [Shell Foundation \(2018\), Energy Storage: Off-grid Trends in Emerging Markets.](#)

335 [World Bank, IFC, GOGLA \(2020\), Off-Grid Solar Market Trends Report 2020.](#)

336 [Efficiency for Access Coalition \(2021\), 2021 Appliance Data Trends. Insights on Energy Efficiency, Performance and Pricing for Off-Grid and Weak-Grid Appropriate Appliances.](#)

However, there is now upward pressure on technology costs due to electronic component shortages, increasing costs of raw materials and parts, and a tripling in shipment costs (see Section 1).³³⁷ A recent survey of OGS manufacturers revealed that many expect the prices in three years' time to be higher than today due to the costs of materials and components remaining high.³³⁸ There are also potential factors that can drive down cost, with normalization of shipping and logistics ranking highly, followed by improvements to the efficiency and standardization of core components. There is hope that perovskite solar cells will bring a step-change to PV performance, though these are a horizon technology that may take three to five years to reach the market.



Off-grid solar technology is now more powerful and versatile. It allows people to leapfrog electrical grids and fossil-fuel sources entirely with quickly-deployable, affordable, low-carbon technology.

Off-grid solar is increasingly versatile, with products and services becoming more customized, interoperable, modular, and circular. This has significant benefits for consumers by giving them greater flexibility and choice, and enabling them to move up the clean energy staircase more easily. It also has the potential to change the mindset of OGS technology; consumers are no longer buying into a single product or brand, but into a marketplace that will help them grow, and serve their growing needs. With the growing range of appliances powered by off-grid systems, and the possible integration with the grid, the technology need no longer be seen as limited and temporary. This creates a new paradigm for integrated energy planning, and represents a sizable opportunity for business and investment.³³⁹

There is a shift towards customisable products. 26% of quality-verified products in 2021 were in a product family³⁴⁰ compared to 7% in 2017 (Figure 57). Whereas the SHS kit certification is for a fixed design (i.e. a single specified PV module, battery, and loads), the Product Family certifies a number of components that can be mixed and matched by the manufacturer to find the right market fit. For example, Shenzhen PowerOak's P-Series Family includes six batteries (from 8Ah to 28Ah), four PV modules (from 55W to 160W), and a 24" and a 32" TV.³⁴¹ These can be combined in a variety of ways to give flexibility in the supply chain and suit local market or customers needs.

Figure 57: The number and type of quality-verified products listed by VeraSol

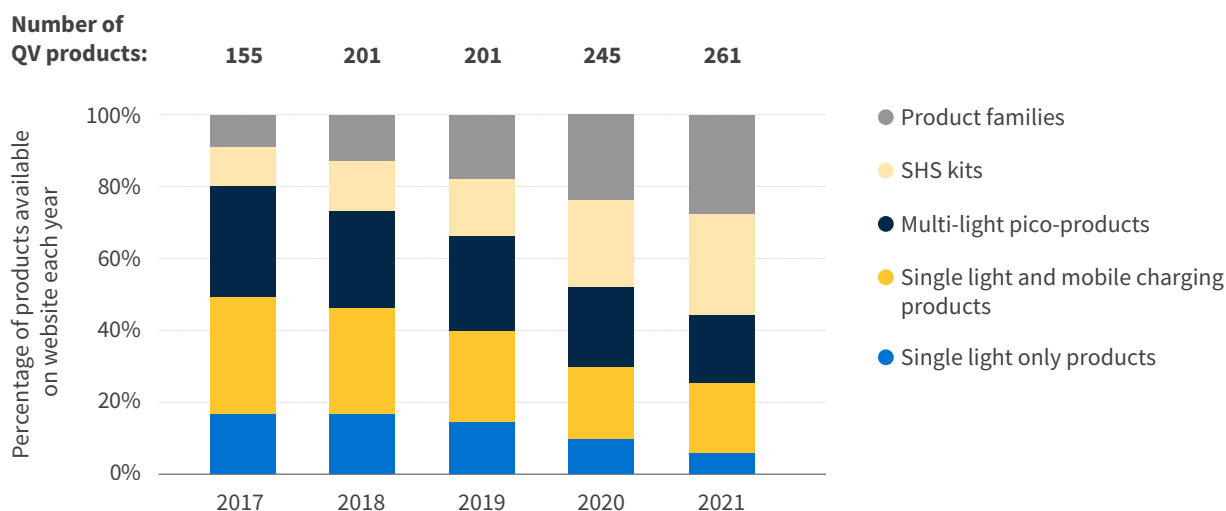

337 [GOGLA \(2021\), Off-grid solar Supply Chain Disruption: 87% of Manufacturers Expect Increased Prices for Consumers.](#)

338 [GOGLA Supply Chain Disruptions Follow-up Survey \(unpublished\) of 30 OGS manufacturers in March 2022. 79% expect solar lanterns to 'increase somewhat' or 'increase a lot', compared to 73% for SHS and 60% for TVs.](#)

339 [Shell Foundation and Rockefeller Foundation \(2021\), Unlocking Climate Finance to Accelerate Energy Access in Africa.](#)

340 [VeraSol \(2022\), Product Database.](#)

341 *Ibid.*

There have been significant efforts to enhance technology interoperability in the industry since it was identified as a game-changer by the Off-Grid Solar Market Trends Report 2020, with advancements in hardware, software, and firmware interoperability. For example, the Connect initiative (see Box 15) has gained traction with prominent companies, including vertically-integrateds and B2B manufacturers from different regions of the world, and the first products that align with the Technical Guidelines are expected on the market in late 2022. These companies see advantages with the prospects

of easier and cheaper integrations with a wider array of appliances on the market, and the value addition for consumers. Other prominent players favor a brand-specific / proprietary model, citing concerns about the challenges of having to provide after-sales service to a wider array of brands, and the prospect of increased competition that would undermine the profitability of the business. The competitive landscape between interoperable and proprietary ecosystems will be an interesting dynamic in the coming years.

Box 15: The Connect Initiative³⁴²

GOGLA, Efficiency for Access, and EnAccess Foundation are leading the Connect Initiative, an industry effort to enhance the interoperability between different brands and models of 12V SHS kits and lights and appliances. The initiative has defined a universal family of connectors, standard electrical characteristics, and device-to-device firmware guidelines for device control and PAYGo activation.

A number of market leaders, including vertically-integrated and B2B manufacturers, have been active in defining the Connector and Electrical Technical Guidelines, and the firmware layers have been defined by Angaza and Solaris in cooperation with their manufacturing partners. The guidelines are open source and designed to complement the IEC 62257-9-5, -9-8 and the VeraSol certification scheme.

The aim is to create a common market for SHS Kits and appliances that improves product quality and price, enables new partnerships and supply chain innovation, and accelerates PAYGo and IoT integration.

Figure 58: The Connect Initiative Universal Family of Connectors for 12V SHS Kits, lights, and appliances

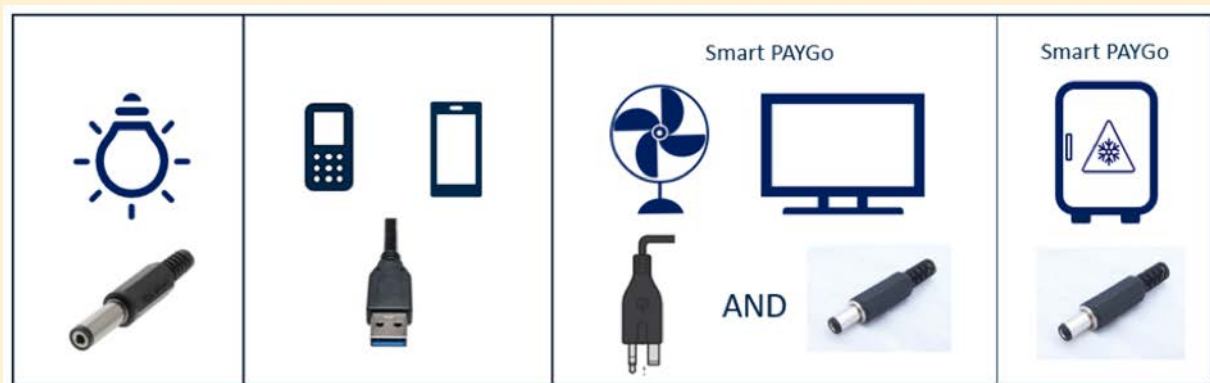

There have been recent advancements in device-to-platform interoperability between the major software-as-a-service players (including Angaza, PaygOps and Paygee).³⁴³ These three PAYGo platforms are now compatible in a way that enables any SHS kit, integrated with one of the platforms, to also integrate the two other platforms. This makes it possible for distributors to work with the platform of their choice without manufacturers having to multiply integration efforts with all PAYGo

Management Platforms and/or produce multiple inventories owing to platform compatibility restrictions

A number of companies are also selling ‘modular’ technology, where customers can add extra battery or PV capacity to increase the run-time or use additional or larger appliances without having to replace their entire system. SolarWorx’s Solego for example has a system with 50W panels and either a 80Wh or 160Wh battery that can be stacked on top of each other to increase the storage capacity

³⁴² [GOGLA \(2022\), The Connect Initiative.](#)

³⁴³ [Solaris Offgrid \(2020\), PaygOps, Paygee and Angaza are becoming Interoperable!](#)

and the maximum power output. Its PAYGo integration offers a single monitoring, control, and payment mechanism as new modules are added to the system. Zola's Infinity is described as a power management technology for light commercial users that integrates solar power and battery storage with power from the grid or a generator to deliver 230 V power. It can operate with a single box (325W PV, 2.3 kWh battery) or with up to ten boxes stacked together. The system can be upgraded as and when needed.

Off-grid solar technology and business models have many elements of circularity in their design, though there is significant scope for optimisation and replication.³⁴⁴

PAYGo companies are increasingly looking at ways to maximize the value of repossessed units³⁴⁵, which in many cases are in full working order and have value for resale after testing and refurbishment. Off-grid solar companies are tackling a number of technological challenges to enhance repair and refurbishment, including improved labeling of materials, design for disassembly, expanding digital tamper-proofing – and more complex challenges such as improved battery management systems³⁴⁶, and enhanced interoperability. Greater investment in R&D and industry cooperation can help unlock these and make the sector more sustainable (see Box 16).³⁴⁷

Box 16: Second-life lithium batteries

The most sizable opportunity for circularity in the off-grid solar sector may be second-life lithium-ion batteries. Studies have found that as many as 73% of used lithium battery cells from OGS products could be rebooted and have a second life, thus turning a costly waste stream into revenue potential.³⁴⁸ Advanced energy storage specialists such as Aceleron and recyclers such as Hinckley in Nigeria have completed pilots with OGS companies, including the local manufacture of second-life batteries and the installation of the first lithium-ion battery treatment equipment in Africa³⁴⁹ - this represents an opportunity for job creation and manufacturing development.

Solaris piloted a battery prototype that retrieves used battery cells from the automotive industry and creates second-life battery packs that can be smoothly integrated with off-grid solar products.³⁵⁰ The second-life battery is intended for use as a replacement for SHS batteries that have reached their end-of-life. It is designed as a tamper-proof external battery that can be attached to a SHS, or removed and recycled, without discarding the entire system. It aims to extend the life of SHS with low-cost, sustainable technology.

6.2 Digital Innovations and the Rise of PAYGo Technology

Off-grid solar technology is digital and uses the Internet of Things (IoT) to enhance the performance and functionality of products. The number of IoT-connected devices globally reached 12 billion in 2020.³⁵¹ The number of IoT enabled devices on the OGS market is growing rapidly – PAYGo sales have a growing market share and

48% of new products listed by VeraSol in 2021 were PAYGo-enabled (and as such are inherently an IoT device), compared to 37% in 2019. This trend is helped by the falling price of IoT sensors. The average price was \$1.30 in 2004 and \$0.38 in 2020³⁵², as well as their dropping power consumption and data requirements that reduce the costs of transmitting the data from the product.³⁵³ Beyond enabling the payment-linked remote lock/unlock at the core of PAYGo, IoT sensors are being used for an increasing range of features including:

- Tailored product design, by giving companies' detailed insights into how people use products to help optimize product design and market fit

³⁴⁴ [GOGIA \(2019\), E-waste Toolkit Module 2 Briefing Note: Design for Reduction of Waste.](#)

³⁴⁵ *In 2019, 7% of PAYGo consumers did not finish their payments and were liable to have their system repossessed, and in the midst of COVID in 2020 this rose to nearly 14%. This represents a significant potential asset base to PAYGo companies (See Section 5.3).*

³⁴⁶ [Solaris Offgrid \(2021\), Solaris Offgrid Develops Smart Battery Technology backed by Global LEAP Awards.](#)

³⁴⁷ [Efficiency for Access Coalition \(2021\), Innovations and Lessons in Solar E-waste Management.](#)

³⁴⁸ *Ibid*

³⁴⁹ *Ibid*

³⁵⁰ [Solaris Offgrid \(2021\), Solaris Offgrid Develops Smart Battery Technology backed by Global LEAP Awards.](#)

³⁵¹ [Techjury \(2022\), 49 Stunning Internet of Things Statistics 2022 \[The Rise Of IoT\].](#)

³⁵² [Statista \(2022\), IoT Average Sensor Costs 2004-2020.](#)

³⁵³ [Efficiency for Access Coalition \(2021\), ICT Solar Appliance Technology Brief.](#)

- Improved system performance by optimizing power usage
- Preventative maintenance
- Linking products and customers to relevant information
- Real-time data on usage and performance for remote monitoring and verification for such as consumer subsidies, RBFs, and carbon credits.



Off-grid solar technology is embracing the Internet of Things (IoT) and artificial intelligence and driving the global digital transformation in homes and businesses across the developing world.

Box 17: Aeris IoT solution provider³⁵⁴

Aeris is a global leader in IoT connectivity solutions that has partnered with Bboxx to provide a complete solution for their product subscriber identity module (SIM), communications network, and connectivity management platform.

Bboxx products are manufactured without a known destination and, as such, with certain mobile network providers, a local SIM card would have to be inserted into the device following sale and then would require local configuration. This process required additional time, cost more, and hindered operational effectiveness.

Aeris is a carrier-agnostic service provider that offers both GSM and CDMA connectivity, including 2G, 3G, and 4G LTE that enables them to serve clients with a single network for all device types in any country of the world. Bboxx can now install the Aeris global SIM at the point of manufacture to negate the need for local configuration to reduce the supply chain costs and deployment time. The Aeris platform allows them to manage their entire portfolio of products across multiple countries from a single platform, and they provide on-demand operational support and a per-device pricing schedule.

Artificial intelligence is being used by some PAYGo players to enhance product design, improve credit risk assessments, and guide consumer engagement operations. Machine learning takes historical information on how input data affects one or more pieces of output data, in order to predict what future input data will result in, giving companies accurate insights in a dynamic market. PAYGo companies are using it to predict which customers are likely to default on a certain product, supporting a credit decision or recommending an adjustment to a different product or payment options. It is also being used to build consumer risk profiles, analyzing payment history to predict risk of default that can be used to guide consumer engagement strategy (see Section 4.2) and to inform the cash flow forecast of the company.

OGS technology and the PAYGo model is also being leveraged to offer digital financial products and services, with a growing range of offerings on the market. PAYGo companies' data infrastructure, credit risk algorithms, and software platforms enable them to offer a range of financial products such as small business loans, school loans, and health insurance. These digital financial products are typically secured against the original SEK using the PAYGo locking mechanism. Large PAYGo players have invested significantly in recent years to build the technology and teams to enable this expansion. Further innovation driven by advancements in data infrastructure and analytics are



'PAYGo everything' is here. The PAYGo technology is being leveraged to offer consumer finance on smartphones, electric motorbikes, and many other devices, as well as to offer digital financial services.

The PAYGo technology that unlocked consumer financing for SHS can be used with any electronic device and is now widely available for dozens of products and brands.³⁵⁵ Angaza, for example, has integrated its PAYGo technology in more than 50 devices, including laptops, electric cookstoves, and biodigesters, whilst K-Pay has also integrated with public toilets and electric vehicle charging points.

354 [Aeris \(2020\), With Aeris, Bboxx Provides Clean Energy Solutions to Off-Grid Communities.](#)

355 [Mastercard \(2018\), PAYGo and the Internet of Things: Driving a New Wave of Financial Inclusion in the Developing World.](#)

At its core, the PAYGo technology is a secure controller that remotely locks the device if the user stops paying, and is connected to a network (GSM, IoT-based, or via offline keypad) that registers payments and activates the control. There is now more flexibility and choice in how this is achieved. The manufacturer or the distributor can integrate the technology by simply adding firmware to the existing controls, or by adding both a controller and firmware.

There are more pricing options, with pay-per-time, pay-per-use, pay-per-amp³⁵⁶, and the range of payment gateways is also increasing, with mobile money wallets, QR codes, Unified Payments Interface (a digital payments platform connected to banks in India) and more. There are also a growing number of PAYGo product development / software-as-a-service providers that integrate the PAYGo technology with a wide range of business tools (CRM, inventory management, sales agent apps, and more) to help distributors build data-driven, digital businesses, though smaller companies with limited expertise and resources may find it difficult to maximize the opportunities this technology presents (see Section 5.4).

PAYGo smartphones have burst onto the market following the development of remote-locking technology. The PAYGo technology has been adapted for smartphones, with a secure locking system embedded in the handset hardware, enabling a company to lock the device if payment milestones are not met. The locked handset only functions for payment top-ups and emergency calls, and once a payment is made, the phone and all services are remotely unlocked. M-KOPA has reached more than one million customers with PAYGo smartphones in Kenya and Uganda in 2020 and 2021 alone.³⁵⁷

Other OGS players have developed partnerships with handset providers including Samsung, Nokia, and Mara Phones, and smartphone consumer finance specialists such as PayJoy have launched in Latin America, India, and South Africa. The need for OGS products to support smartphones is therefore becoming increasingly important. In some cases, charging a smartphone can take over 24 hours, which is clearly unsatisfactory. There are many different fast charging protocols which makes it

costly and complicated for OGS manufacturers, suggesting that industry guidelines and consumer-facing labels may become necessary. Nonetheless, the rapid growth of PAYGo smartphones deepens the complementary relationship between OGS players and the mobile sector³⁵⁸ and may enhance the profitability of OGS with a “pull product” that is relatively easy to sell (see Section 5.4).

6.3 Off-grid Appliance and Productive Use Technology and Market Maturity



There have been rapid advancements in the maturity of a few appliances and productive use technologies, but more R&D investment is needed to accelerate a wider array of technology onto the market.

Highly-efficient direct current (DC) appliances purpose-made for off-grid customers are now commonplace in the product range of PAYGo companies. Affiliates have sold 1.5 million TVs, 1.4 million fans, nearly 30,000 fridges, and 64,000 SWPs. These appliances have benefited from intense R&D efforts that have spurred improvements in the efficiency, performance, durability, and cost. People with grid electricity have access to a much wider range of affordable appliances and productive uses, which can also be available to people in off-grid areas with further R&D. The Technology and Market Maturity Map (Table 3) shows the many other potential use cases that could collectively transform the lives and productivity of people in off-grid areas.

³⁵⁶ K-Pay India is an example of a company offering these solutions. For more information, please see [Our Solution – KPay \(kpayasyougo.com\)](#).

³⁵⁷ GSMA (2022), [M-KOPA: Applying the PAYGo Model to Smartphones in Africa](#).

³⁵⁸ GSMA (2022), [What is the Value of Pay-as-you-go solar for Mobile Operators?](#)

Table 3: Technology and Market Maturity Map of solar appliance technologies for off-grid use cases^{359,360}

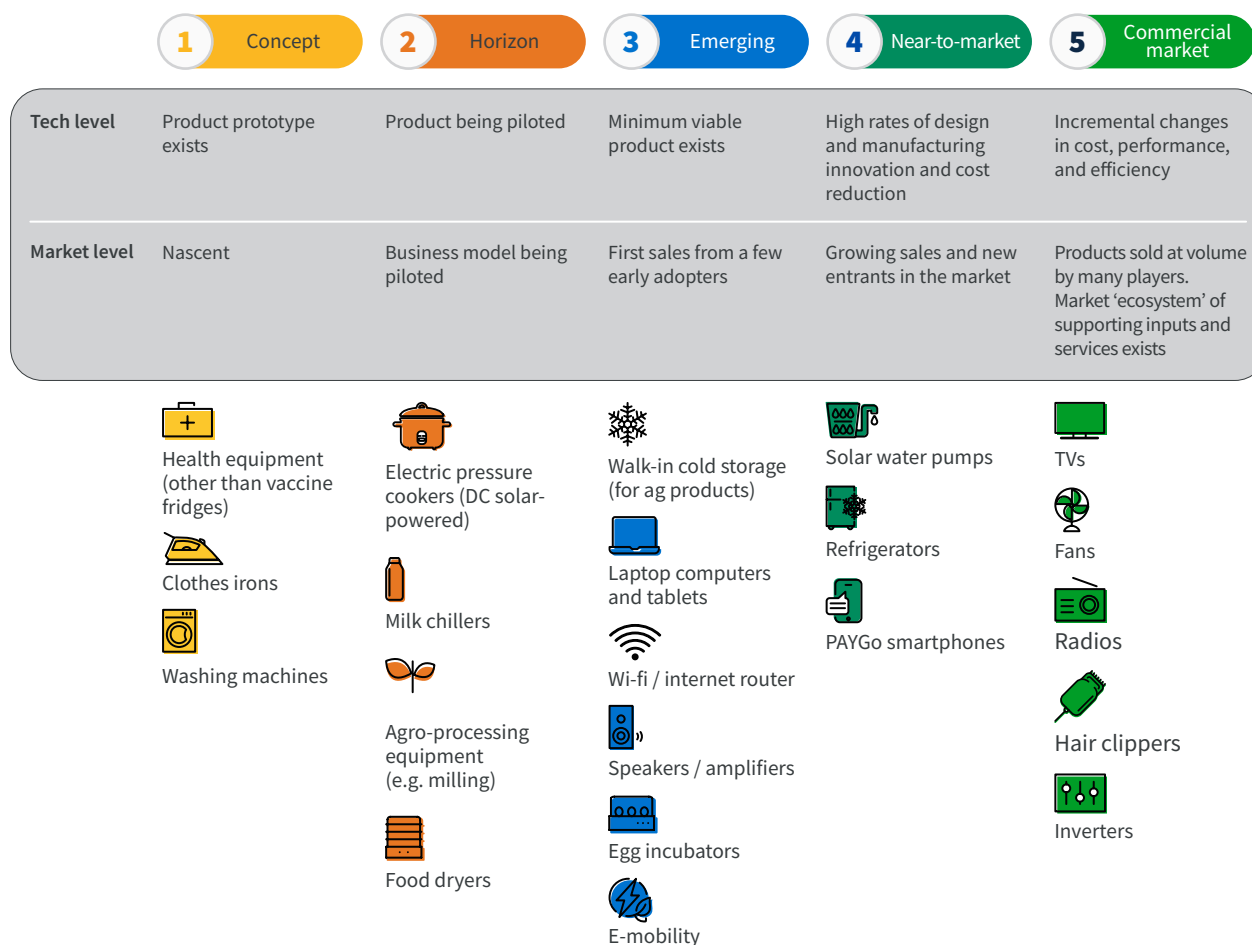

Enabling platforms / components – PAYGo technology (IoT sensors, comms networks, firmware, software, etc.). Smart batteries. Permanent Magnet Motors. Phase Change Materials.

Emerging qualities of technology – Digital. Customisable. Interoperable. Modular. Circular.

Solar water pumps (SWP), seen as an ‘emerging’ technology two years ago, are now classified as ‘near-to-market’. There are a wide range of technologies in this product category (<1kW PV input for one- to five-acre smallholder farmers), including submersible and surface pumps for low, medium, and high heads (up to 100m) and flow rates up to 80 m³/day.³⁶¹ 42 products from 21 brands have been quality-tested by VeraSol, including renowned global players (such as Grundfos), PAYGo specialists (e.g. SunCulture), and numerous Chinese and Indian brands

(e.g. Bengal Solar), and there are many hundred more that are available on the market.³⁶² SWPs on the market today are more efficient, affordable, and impactful - they now typically feature brushless direct current (BLDC) motors, PAYGo capabilities (with firmware and GSM-enabled), and are IoT-enabled for enhanced monitoring, controls, and provision of information to the user.

The reliability of SWPs appears to have improved, with the customer Challenge Rate dropping from 45% in 2018/19 to 32% in 2020/21 (and the Resolution Rate has

359 Adapted from *Efficiency for Access Coalition (2021), Solar Appliance Technology Briefs*.

360 The technologies have been classified based on the authors’ understanding of the market and stakeholder consultations. It should be noted that some technologies such as refrigerators defy simple classification as they include a range of product sub-segments that are at varying stages of maturity, for example vaccine fridges have been sold for decades, whereas domestic fridges using phase change materials are an innovation. Furthermore, there may be products or brands that are ahead of (or behind) the curve compared to the level designated on this map.

361 VeraSol (2022), *Product Database*.

362 A market survey conducted by the LEIA program found more than 500 SWPs across 10 off-grid solar countries in Africa and South Asia.

increased from 52% to 57%)³⁶³, though there is clearly still room for improvement of product and service. The most common issues for the customers who say they've experienced a challenge (in 2020/21) are unreliability, poor/faulty valves and controllers, and poor battery. Despite the improved reliability, the NPS score dropped from 55 in 2018/19 to 46 in 2020/21, with detractors - just 7% of all respondents - citing a need for improved pump durability, with identified issues including rust and corrosion, dry run protection, improper water ingress protection, and battery issues.³⁶⁴

Efficient motors are key to reducing SWPs' energy consumption and unlocking lower total system cost. All but one of the 34 SWPs tested for the Global LEAP Awards used a highly efficient BLDC motor, an indication that market leaders have already adopted these technologies to increase overall pump efficiency.³⁶⁵ The average wire-to-water efficiency for surface pumps is 29% on a typical solar day, compared to 33% for submersible pumps, though

there is a high variation among all pumps tested, with a minimum of 11% and a maximum of 60%.³⁶⁶

Solar cooling, seen as an 'emerging' product two years ago, is now considered 'near-to-market' following intensive research and development efforts due to the increased demand for vaccine storage and high potential for productive use. There are an array of fridges, freezers, and combined fridge-freezers on the market for the variety of distinct use cases, that have seen trends to higher efficiency and lower costs thanks to technological advancements (Figure 59). 95 Fridges from 50 brands have been quality-tested by VeraSol, and there are many hundred more that are available on the market, with both AC and DC power systems, and solar-battery-powered and solar direct drive designs.³⁶⁷ Leading refrigerator manufacturers have driven technology innovations, in-house and through donor-supported programs, and achieved significant efficiency gains. However, other brands found on the market have a long way to go to achieve similar performance.

Figure 59: Use case and product segmentation of off-grid solar cooling technology³⁶⁸

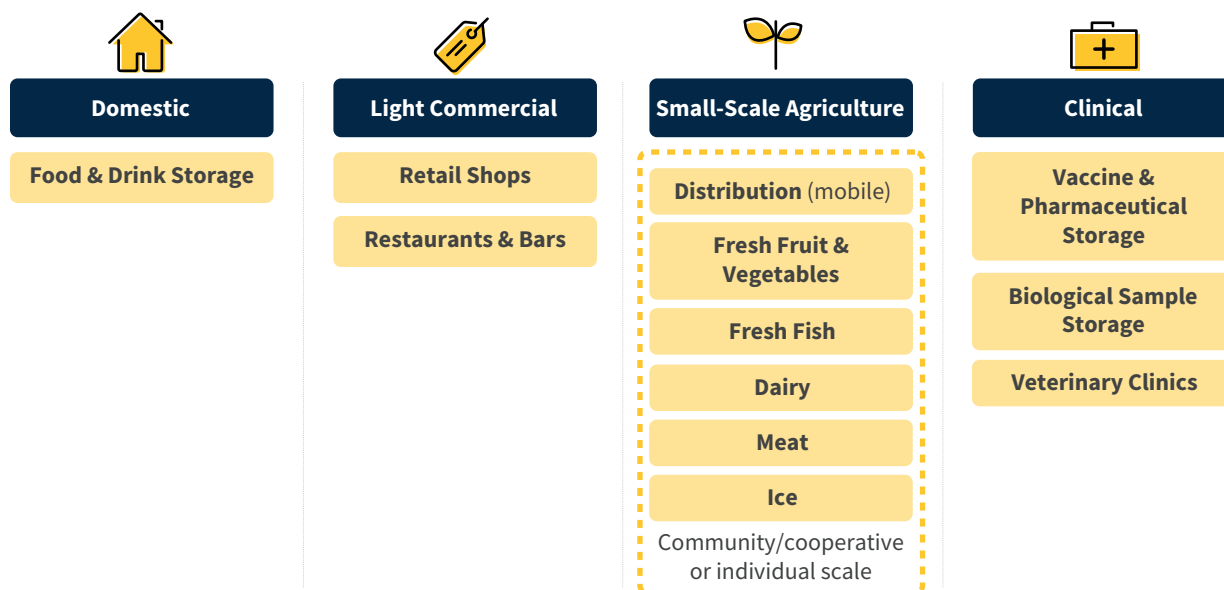

³⁶³ [Efficiency for Access Coalition \(2021\), Uses and Impacts of Solar Water Pumps.](#)

³⁶⁴ [Efficiency for Access Coalition \(2021\), 2021 Appliance Data Trends. Insights on Energy Efficiency, Performance and Pricing for Off-Grid and Weak-Grid Appropriate Appliances.](#)

³⁶⁵ [Efficiency for Access Coalition \(2022\), Solar Water Pumps.](#)

³⁶⁶ [Efficiency for Access Coalition \(2021\), 2021 Appliance Data Trends. Insights on Energy Efficiency, Performance and Pricing for Off-Grid and Weak-Grid Appropriate Appliances.](#)

³⁶⁷ A market survey conducted by the LEIA program found nearly 500 refrigerators across 10 off-grid solar countries in Africa and South Asia, with about 1/3 of these being low voltage (10 – 48V). Many of the 230V fridges are unlikely to be optimized for the limited energy available from off-grid solar systems.

³⁶⁸ [Efficiency for Access Coalition \(May 2020\), Use Cases and Cost Breakdown of Off-Grid Refrigeration Systems.](#)

The fridge product sub-segments are at different levels of technology and market maturity¹²²:

- Domestic and light commercial technologies are already being sold in many markets, though the high cost remains a critical barrier to uptake. There is significant product overlap for domestic and light commercial sector appliances, with units generally sized less than 150 liters, though products up to 300 liters are available. The Global LEAP Off-Grid Refrigerator Test Method is now in process of being formalized as an IEC quality standard³⁶⁹, and field-testing standards have also been developed to demonstrate how the product may operate under ‘real-life’ conditions.³⁷⁰
- Small-scale agricultural applications are very promising, but the technology is still relatively young, and, in many markets, they remain unproven. This segment has a range of technologies, including walk-in cold rooms, milk-chillers, icemakers, and electric chiller vehicles, that are sized to serve producer co-operatives and as part of aggregation and distribution chains, rather than for individual smallholder farmers.³⁷¹
- Clinical applications are already viable for off-grid refrigeration and have seen a surge in interest and investment due to the COVID-19 pandemic. This is a mature technology that is subject to rigorous performance standards given the critical need to keep vaccines in a permissible temperature range.

Recent innovations in fridge insulation, efficient compressors, and better controllers are driving down costs, and improving efficiency and durability.^{372, 373} One example is the use of phase change materials (PCMs) that are increasingly being adopted into off-grid and weak-grid cooling technology. PCMs collect thermal energy during the cooling cycle that is then released during the melting cycle, maintaining the cooling temperature with a lower run time of the compressor (see Box 18).³⁷⁴ Advanced insulation materials are also improving efficiency. For example one product uses aerogel that is up to three times more effective than traditional expanded polystyrene.³⁷⁵ Another trend is the use of super-efficient variable speed compressors that use permanent magnet motors that are more efficient, and are often smaller compared to standard motors, and make installation and maintenance easier.

Box 18: SureChill’s phase change material and smart controller technology³⁷⁶

SureChill has developed a domestic refrigerator with PCM that harnesses a unique property of water to enable continuous cooling from inconsistent power. It removes the need for a battery by converting electricity into thermal energy and storing it in the form of ice in a water-filled chamber that surrounds the interior where food, drinks and medicine can be stored.

SureChill has also integrated a smart controller with features that improve the efficiency and performance of the product. The controller has eliminated the need for large capacitors that had been required to meet the high in-rush current of the DC compressor, and protects the compressor from electrical faults and power surges. It monitors the state of the refrigerator and the power supply to optimize the compressor operation to maintain an optimum temperature without compromising other loads on the system. It has a versatile design for use in solar direct-drive and battery-powered systems, with a range of compressors, and a communication module that enables integration with common PAYGo firmware.

SureChill estimates that adding a smart controller led to a 32% cost reduction in the compressor system, and results in a \$84 price reduction for the end-user.

369 [VeraSol \(2022\), Global LEAP Off-Grid Refrigerator Test Method.](#)

370 *The daily energy consumption measured during field testing differed considerably from lab-tested measurements, with 88% of tested refrigerators consuming up to 124% more energy in the field.*

371 [Powering Agriculture \(2020\), Technology Case Study: Clean Energy Cold Storage.](#)

372 [Efficiency for Access Coalition \(June 2021\) Refrigerators. Solar Appliance Technology Brief.](#)

373 *However, most of a refrigeration system’s cost comes from the battery, solar panel, charge controller, shipping, duties, and taxes, regardless of geography or model. A holistic approach of policy and supply chain development is needed to dramatically improve affordability; improvements in efficiency alone will not be sufficient. For more information, please see [Efficiency for Access Coalition \(2021\), 2021 Appliance Data Trends. Insights on Energy Efficiency, Performance and Pricing for Off-Grid and Weak-Grid Appropriate Appliances.](#)*

374 [Efficiency for Access Coalition \(2021\), Phase Change Materials: The Future Of Efficient Refrigeration?](#)

375 [Efficiency for Access Coalition \(2021\), Retrofitting Refrigerators To Create an Affordable, Energy Efficient Cooling Solution.](#)

376 [Efficiency for Access Coalition \(2021\), The Sure Chill Company - How Smart Controllers can help to Unlock Universal Access to Domestic Refrigeration.](#)

While still relatively new to African and Asian markets, solar-powered walk-in cold room technology targeting key links within the agricultural value chain is now emerging. Though walk-in cold rooms are very energy intensive and expensive, innovation around the use of solar direct drive (SDD) technology can eliminate the use of expensive batteries for energy storage.³⁷⁷ Few cold storage rooms use only SDD technology, but a growing number are integrating phase change materials to enhance energy efficiency for off-grid use cases. To reduce costs, some developers are innovating with locally available materials such as clay bricks or recycled plastics for insulation, rather than the more expensive Polyurethane (PUF) - however these are often less insulating and are yet to be widely adopted. Combining such technological improvements with CAAS business models³⁷⁸ can help unlock cold chains that may enable developing countries to raise food supply by 15% – about 250 million tons.

Manufacturers of small-scale agro-processing machinery have continued to make headway, improving product efficiency, affordability and product-market fit, but business models need to be proven to drive demand and sales. Some machinery developers have made significant performance improvements over the last two years. Agsol, for example, has substantially reduced prices, more than doubled milling rates, and increased energy efficiency with their new MicroMill. According to Agsol, the MicroMill is 2.5 times more efficient than other electric milling machines on the market and can deliver the small sieve size that consumers desire. Although the mills produce flour at 60 kg/hr compared to 120-150 kg/hr by a typical diesel mill they are over 60% more profitable compared to a new diesel mill given the lower running costs incurred, with no diesel costs and minimal maintenance costs.³⁷⁹ This indicates potential to out-compete diesel mills in the market, improve accessibility to essential services, and positively impact GHG emissions by displacing diesel use. It also indirectly improves income generation and food security for end users. Nonetheless, the market for small-scale milling remains nascent, and business model validation and appropriate avenues for asset financing, including uptake from off-grid-solar companies, has yet to be demonstrated.

E-mobility products are now seen to be emerging with 2-wheel and 3-wheel (2w / 3w) vehicles being the fastest growing form of transport in emerging markets due to their small size and relative affordability.³⁸⁰ Most micro-e-mobility vehicles consist of a battery and electric motor-powered system, typically with permanent magnet motors (PMM) as they offer greater energy efficiency, performance and reliability than other electric motors. With only 10% of the number of parts found in a typical petrol engine, electric motors are easier and cheaper for users to maintain. E-vehicle companies are currently focusing on urban areas, though the battery-charging is considered a good fit with mini-grids that are seeking to increase the energy offtake and welcome deferrable loads. The electricity demand of even a small 2w e-moto is beyond the capacity of the typical SHS. Fishing boats in East Africa are also shifting to electric-motors that have lower running costs, and create less noise and fumes, than fossil-fuel engines.

Battery-powered e-vehicles now compete with hybrid and internal combustion engine (ICE) vehicles. Though 2w e-motos have higher up-front costs, they can reach total cost of ownership parity with a petrol-engine moto in two to three years due to lower per-kilometer and maintenance costs. Upfront costs are driven primarily by battery technologies, as the battery packs account for almost 40% of an electric vehicle. In markets such as India, low-cost lithium-ion (Li-ion) batteries are projected to dominate the 2w and 3w e-mobility market by 2025 due to their lighter weight and higher energy densities.³⁸¹ To further reduce upfront costs and increase affordability, e-mobility solutions being adopted across emerging markets include retrofitting existing ICE vehicles, as well as integration with PAYGo technologies and ‘charging as a service’ models.

On the horizon, Electric Pressure Cookers (EPCs) offer the cheapest alternative to biomass cooking solutions in areas with low cost grid connections and high charcoal costs. EPCs can reduce energy costs by 90% and take 75% less time compared to traditional cooking methods.³⁸² In 2020, the Global LEAP Awards program developed the first test method to assess the energy performance, quality and safety of EPCs. The average electricity consumption was found to be between 370Wh and 868Wh per day depending on the size of EPC (from 1 to 9 liters)³⁸³, which represents a large electricity demand that is prohibitively expensive from an off-grid system. Furthermore, the market is

377 [Energy for Access Coalition \(2021\), Walk in Cold Rooms, Solar Appliance Technology Brief.](#)

378 [NextBillion \(2020\), Taking Cold Chains Off-Grid: How Solar Powered Cold Rooms Could Dramatically Reduce Food Waste in Sub-Saharan Africa.](#)

379 [Next Billion \(2020\), 2020 Most Influential Article Candidate: Milling on Mini-Grids: How Africa's Largest Crop Could Go Diesel-Free.](#)

380 [Efficiency for Access Coalition \(2021\), E-mobility, Solar Appliance Technology Brief.](#)

381 [Bloch et al. \(2019\), Breakthrough Batteries: Powering the Era of Clean Electrification.](#)

382 [MECS \(2019\), The Kenya e-cookbook; Efficiency for Access Coalition \(2021\), Electric Pressure Cookers, Solar Appliance Technology Brief.](#)

383 [Efficiency for Access Coalition \(2021\), Electric Pressure Cookers, Solar Appliance Technology Brief.](#)

currently dominated by AC-powered EPCs, which represents a barrier for uptake in off-grid households, and the cost of an AC EPC is \$22 and considerably more for a DC EPC. EPCs are currently only affordable for grid-customers, with some pilots exploring viability for mini-grid customers, and further R&D needed to enhance the efficiency and reduce costs to make them accessible for off-grid solar consumers.

Beyond SWP and refrigerators, permanent magnet motors (PMMs) have the potential to transform the market for solar-compatible fans, electric vehicles, washing machines, etc. in off- and weak grid settings by significantly improving the energy efficiency, performance, reliability, and cost.³⁸⁴ Appliances with PMMs consume between 22% and 42% less electricity than conventional AC motor appliances and can deliver 30% cost savings to off-grid consumers, thus allowing for the use of larger and additional appliances. In addition to electricity savings, appliances with PMM offer a more reliable service and expanded set of features coveted by consumers. Whilst affiliate manufacturers have been quick to adopt PMM, significant technological and market barriers persist for the wider adoption of this innovation.

6.4 Distributed Solar and Storage Technologies with Efficient Appliances to Strengthen the Weak Grid



Distributed solar and storage technologies combined with high-efficiency appliances could transform electricity access for homes and businesses on the weak grid.

OGS can improve electricity access for an estimated 775 million people living with a weak grid connection.³⁸⁵

The electricity supply for weak grid customers is typically inadequate, unavailable, unreliable, and unsafe - though the quality of supply varies significantly, with some areas experiencing only minimal disruptions, whereas others have only a few hours of power per day, including 160 million grid customers in Africa that have less than 12 hours per day.³⁸⁶ This particularly constrains businesses from investing in appliances and machinery, since their ability to use them reliably for income generation is hindered. 16% of households in India have also experienced a safety issue with their 230V electricity supply in the last year³⁸⁷, and nearly 30 people die every day across the country.³⁸⁸

Weak grid customers are forced to rely on back-up technologies that are dangerously polluting, and expensive.

Fossil-fuel generators proliferate as a back-up technology. In Nigeria alone there are an estimated 22 million small petrol generators being used to power homes and small businesses, this is eight times the grid's peak capacity.³⁸⁹ Generators are also expensive, with an average service cost of \$0.30 per kWh for the fuel alone. In India, there are 55 million homes with a lead-acid battery and inverter for back-up power though a further 218 million with little or no back-up.³⁹⁰ These systems are typically inefficient and expensive as they feature basic battery technology, low-cost inverters, and conventional AC appliances with low efficiency.

New technology segments are emerging that integrate distributed solar and storage with the weak grid to dramatically improve the quality and affordability of electricity access. Distributed solar and storage can be integrated with the grid supply³⁹¹ in a way that increases the availability and reliability of power for a home or business. The battery is charged by the grid and/or solar panel and provides power to the loads during the grid outage. The power can be used in low voltage (e.g 12V or 48V) mode on direct current (DC) with high-efficiency lights and appliances, or the power can be at grid voltage, with an inverter taking power from the battery to alternating current (AC) for conventional loads and appliances. There is also an emerging class of smart lights and appliances that have inbuilt batteries that can continue working during outages, and appliances that work in both DC and AC mode. Digital technology is a key feature, with IoT system monitoring and management, and smart metering, billing, and payments.

384 [Efficiency for Access Coalition \(2021\), Solar Appliance Technology Brief: Permanent Magnet Motors.](#)

385 [IEC, World Bank Group \(2019\), The Dirty Footprint of the Broken Grid: The Impacts of Fossil Fuel Back-up Generators in Developing Countries.](#)

386 [World Economic Forum \(2021\), Closing the Loop on Energy Access in Africa.](#)

387 [Smart Power India, The Rockefeller Foundation, NITI Aayog \(2020\), Benchmarking Distribution Utilities.](#)

388 [Times of India \(2019\), Electrocutting kills nearly 30 Indians a day.](#)

389 [Access to Energy Institute \(2019\), Putting an End to Nigeria's Generator Crisis: The Path Forward.](#)

390 [GOGLA \(2020\), Opportunities for Hybrid AC-DC Infrastructure in India.](#)

391 *Note: whilst the analysis in this report focuses on integration with the grid, the innovation could likewise relate to mini-grids.*

There is much innovation in this space, with off-grid solar companies and donor-funded R&D programs targeting solutions that are affordable and scalable (see Box 19). However, it is a complicated and fragmented market, with an array of grid supply scenarios, possible system voltages

and architectures, and variety of appliance types, that make it challenging to standardize and commercialize. Four market segments, defined by the system architecture, with high potential are emerging.

Segment One: Low voltage for all loads and appliances

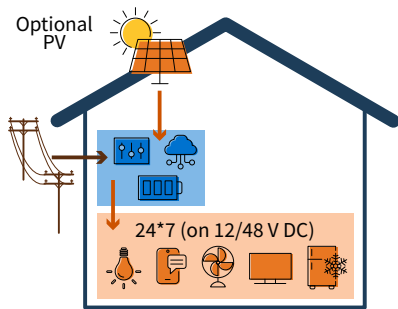

Customer segment: Low-income. Very weak supply / new grid customers. Zero or low appliance ownership.

System architecture: The grid supply is converted to low voltage (e.g. 12V or 48V) direct current (DC) with a rectifier.

When the grid is available, it powers the loads through a rectifier and charges the battery. When the grid is not available, the battery powers the loads directly.

All the loads are high-efficiency Low Voltage DC. A smart meter enables metering, billing, and payments, and the IoT manages system performance.

Segment Two: Low Voltage and Grid Voltage in parallel

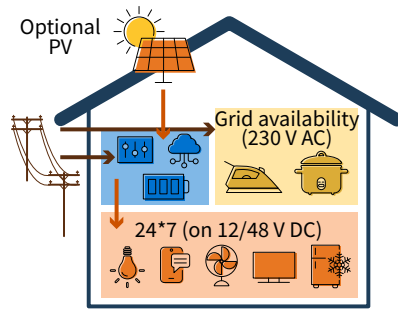

Customer segment: Low-Middle income. Weak supply. Some appliance ownership. Domestic and Light Commercial.

Technology Description: As with Segment 1, a range of 'core' loads and appliances are on the low voltage DC line, with the battery back-up providing high availability and reliability.

High power loads are on a parallel grid-voltage AC line and can only be used when the grid is available. There is flexibility as to where specific appliances may sit, for example, there may be a DC TV on the low voltage line, or an AC TV on the high voltage line.

Segment Three: Grid Voltage using appliances with in-built battery back-up

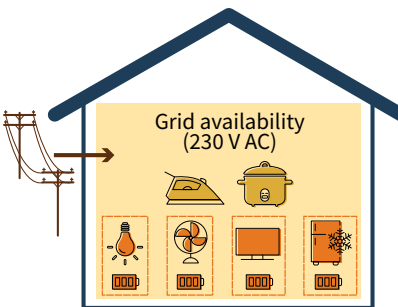

Customer segment: Low-Middle income. Weak supply. Some appliance ownership.

Technology Description: All the loads and appliances are powered by the grid-voltage AC line. Lights, fans, TVs and other select appliances have in-built batteries and electronics that enable continued operation during power outages.

Segment Four: Grid Voltage with battery back-up and inverter

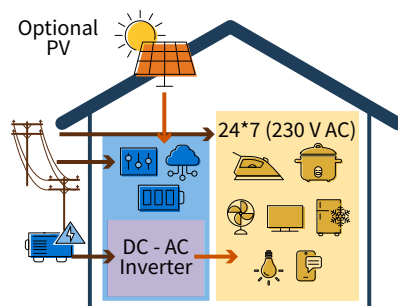

Customer segment: Middle income. Weak supply. Some appliance ownership. Domestic and Light Commercial.

Technology Description: When the grid is available, it directly powers the conventional AC loads and charges the battery.

When the grid is not available, the battery powers the loads via an inverter. Solar PV and/or a fossil fuel generator may be used for additional generating capacity to supplement the grid and boost the battery during outages.

Box 19: Solar generators gather pace in Nigeria³⁹²

The Access to Energy Institute (A2EI) has developed a solar generator for small businesses in Nigeria. It is a demonstration of how Segment Four can provide reliable and affordable power for weak grid customers.

Their research of fossil-fuel generators used by street markets and small shops found that 80% had a power output of less than 1kW, and that on average, they are running on only 22% of their respective nominal load. A solar generator with an inverter is capable of meeting their power needs, and can do so more affordably than fossil fuels. A2EI has designed a solar generator to provide an uninterrupted power supply that places a special focus on usability and affordability. There are two models that are turnkey solutions equipped with 1200 Wh / 2400 Wh battery, 820Wp PV panels, and a 1 kVA / 3 kVA inverter, and IoT sensors with the ability to remotely monitor system performance. The solar generator can be connected to the grid and thereby acts as a back-up to ensure uninterrupted electricity access, but also functions as a standalone PUE off-grid solution where no grid is available. The technology is open source, with the hardware specifications and system data publicly available.

A2EI has installed over 728 solar generators in Nigeria, which translates into 590kW of solar PV and 180 tons of carbon mitigated, officially confirmed with Gold Standard certificates. A solar generator offers a more reliable supply, and eliminates the recurring cost of fuel. The fuel savings pay for the solar generator and over five years (the minimum lifespan of the solar generator) offering an estimated saving of over \$1,700.



The component technologies for distributed solar and storage on weak grid are mature and available, but further R&D is needed on system design, integration, and control.

The component parts of Segment One to Four are all mature technologies, though the system integration architectures remain niche. Many companies have products in customers' homes and businesses as per the Segment One to Four architecture, though the industry is fragmented. There is a lack of technical standards and interfaces for hardware, software, and firmware to build supply chains and partnerships and achieve economies of scale. Furthermore, there is no strong consumer-facing brand or labels that can drive marketing and sales. And critically, the technical standards and regulations for integrating distributed solar and storage with the grid are in their infancy. These barriers are now the focus of R&D programs.

The solar PV and battery need to be appropriately sized to ensure reliable power and cost optimisation. This is challenging to standardize given the variability in the availability of supply from the grid and solar, and the demand from the loads, the most cost-effective solution will depend on the component costs and financing options.

The dual input of grid and solar PV increases the resilience of the system and reduces the electricity demand from the grid. Though the system may function well without solar, relying simply on the grid and battery back-up. This may be the lowest upfront cost for households, though they may be able to save on their ongoing costs with the addition of solar PV.

Advanced systems such as the A2EI solar generator or Zola's Infinity, can also accept power from a diesel generator, and control the system to ensure constant power and cost-optimisation. Battery storage is an essential component that features in every system, with the simplest systems for lighting and phone charging requiring very small, low-cost batteries. Larger systems with a range of appliances have a few kWhs of storage. Market forecasts show that improvements in electricity access over the next decade could drive an estimated sevenfold increase in stationary battery capacity in sub-Saharan Africa, from 11GWh in 2020 to 83 GWh in 2030³⁹³ across grid, mini-grid, and off-grid solar segments.

There are new categories of appliances emerging, ones with a low voltage direct current (DC) input, ones with dual AC and DC inputs, and others with AC input and an integrated battery.³⁹⁴ These are all essentially DC, making them more efficient and reliable than their conventional AC counterparts, though they are less available and more expensive. Whilst these new technologies bring a range of possibilities it also introduces a complex array of options for companies and customers to evaluate. Appliances may be rated for use with DC or AC, and powered by the

392 [Access to Energy Institute \(2021\), A2EI's Solar Generators Gather Pace in Nigeria.](#)

393 [World Economic Forum \(2021\), Closing the Loop on Energy Access in Africa.](#)

394 [GOGLA \(2020\), Opportunities for Hybrid AC-DC Infrastructure in India.](#)

electrical AC grid, DC or AC mini-grid, or DC solar home system. Where the power supply and appliance are not directly compatible, a power converter – an inverter or a rectifier – is required. An inverter converts DC power to AC power, while a rectifier performs the reverse conversion of AC to DC. The use of a power converter adds additional power consumption, and typically increases the complexity of the system set-up, as well as adding cost and quality considerations.³⁹⁵

In India, as many as 55 million households are using a lead-acid battery with an inverter, 90% of which are below 1.5 kVA.³⁹⁶ When used with conventional AC appliances, these systems can be very inefficient and significantly increase the energy demand from a user, increasing their costs and putting additional stress on weak grids. The global inverter market is projected to grow from \$13 billion in 2020 to \$27 billion by 2025³⁹⁷, with demand driven by residential solar customers in developed economies, and large developing markets such as India.

Sophisticated control technology is needed at product-level to integrate power inputs from the grid and solar PV, manage energy storage and demand from a range of appliances, and provide metering, billing, and payments services. The capabilities and technical standards that the solar PAYGo sector has developed to remotely monitor and control SHS using IoT and AI are a solid foundation for this purpose. The global Smart Home market - estimated at \$84.5 billion in 2021³⁹⁸ - is also a source for innovation and inspiration. For example, the Open Connectivity Foundation is a global, member-driven organization that has developed technical standards to enable trust, interoperability, and secure communication between IoT devices and services in homes and buildings.³⁹⁹

The customer-centric controls in the Smart Home market are also renowned, with Amazon's Alexa, Apple's Siri, and Google's Assistant allowing users to control lighting, temperature, and home theaters via voice or app from the home or remotely. Smart electricity meters are now commonplace in many countries - hundreds of millions of units are installed every year and the global market was \$20 billion in 2020, including electricity, gas, and water meters.⁴⁰⁰ Traditionally smart meters enabled the remote monitoring, control, and payments of electricity consumption, though with the arrival of IoT platforms, advanced meters are now able to carry out a broader range of data analytics, system management, and notifications (see Box 20).

If deployed at scale, distributed solar and storage technologies could transform electricity networks into smart grids; this represents a challenge and opportunity for utilities, network operators, and regulators. For network operators, it brings changes to demand profiles at the level of individual customers, sub-stations, and the wider grid that would require planning and management. Digital tools to enable monitoring and control, including demand-side management, are on the market though these are not widely adopted, and often not being used to their fullest potential. Product technical standards and regulations to ensure safety are also necessary. For example, if there is a grid power outage, anti-islanding features stop houses with inverters from electrifying the nearby grid and electrocuting workers repairing the fault. Distributed solar and storage technology is a ground-up approach to build digital electricity grids that are less carbon-intensive, more reliable, and more financially viable.

Box 20: SparkMeter⁴⁰¹

SparkMeter is a US-company that offers advanced metering and grid management solutions to distribution utilities and mini-grids in developing countries. SparkMeter's technology allows utility companies to gain greater insight into grid performance through its plug-and-play management software. The software creates a 'digital twin' of energy grids by combining real-time data with detailed models, increasing grid visibility, making it easier to respond to congestion, line and transformer stress, and plan for new grid dynamics such as distributed energy generation. The technology helps utilities to improve their reliability and collections, which can accelerate the retirement of diesel generators while deploying cleaner sources of energy.

395 [Efficiency for Access Coalition \(2020\), Performance And Efficiency of Off-Grid Appliances With Power Converters.](#)

396 [GOGIA \(2020\), Opportunities for Hybrid AC-DC Infrastructure in India.](#)

397 [MarketsandMarkets \(2022\), Inverter Market Size Share and Trends forecast to 2025.](#)

398 *A smart home refers to a convenient home setup where appliances and devices can be automatically controlled remotely from anywhere with an internet connection using a mobile or other networked device.*

399 [Open Connectivity Foundation \(2022\), Homepage.](#)

400 [MarketsandMarkets \(2022\), Smart Meters Market Size.](#)

401 [SparkMeter \(2022\), SparkMeter Raises \\$10 Million to Accelerate Growth in the Implementation of its Advanced Metering Solution Globally.](#)



Strengthening the grid with distributed solar and storage technologies is a vast opportunity for the off-grid solar industry. It can also benefit utilities by enhancing customer satisfaction, improving revenue, and offering ancillary services.

Distributed solar and storage with efficient appliances has the potential to unite off-grid and weak grid customers in Africa and Asia with a common technology base. This would create a huge market for electricity access that would drive economies of scale and represent a massive opportunity for companies. The investment opportunity in achieving universal electricity access with off-grid solutions and replacing nine million back-up diesel generators is estimated at \$200 billion - a sizable sum even before considering the hundreds of millions of other weak grid customers that could be well served with this technology. This scenario would also mitigate more than 500 MT carbon emissions over the next decade, approximately equivalent to the annual emissions of 130 coal-fired power plants.⁴⁰²

The ability of distributed solar and storage to integrate with the grid and mini-grids can enhance the consumer journey up the energy staircase and create a new paradigm for integrated electricity planning. It removes the distinction between short-term off-grid electrification and long-term grid electrification, and makes the OGS product a future asset in the distribution grid, that can be seen both as

a short or medium-run asset to increase access, as well as a long-term asset for the grid. A grid customer with a battery will have higher satisfaction from the grid connection – and the remote monitoring, control, and payment technology can be advantageous for the grid operator.

Distributed solar and storage has the potential to improve the reliability and quality of electricity supply which is likely to yield greater willingness and ability to pay and boost the revenue for utilities. It could potentially offer ancillary services to the grid operator, such as reducing the peak load, advancing digitization of the grid, or deferring investments in grid reinforcement/transmission upgrades.

Introducing distributed solar and storage at scale to the grid will require new partnerships and cooperation between traditionally off-grid and on-grid players.

As the Utility 2.0 initiative makes clear, centralized and decentralized electricity can work together to identify critical path technology, process, and regulatory interventions needed to transform electricity systems into robust networks that deliver reliable, affordable, universal access for all.⁴⁰³

It is now clear that the term *off-grid solar*, used to describe the technology in the industry - and the brand of the industry itself - is no longer all encompassing. The possibilities for distributed solar and storage to integrate with the weak grid broaden the scope beyond off-grid, whilst the wide array of appliances, productive use equipment, and digital financial services go beyond solar technologies. There is an opportunity for the industry to rebrand itself to reflect these technological advancements and to position itself firmly and clearly in the minds of customers, investors, donors, and governments.

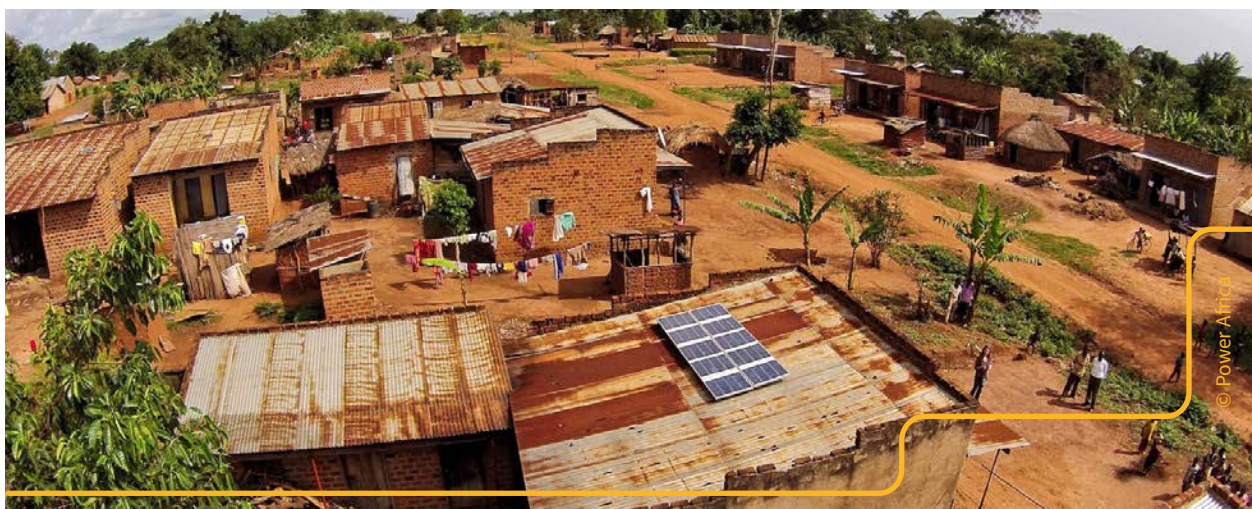

402 [Shell Foundation and Rockefeller Foundation \(2021\), *Unlocking Climate Finance to Accelerate Energy Access in Africa*.](#)

403 [Power for All \(2019\), *Universal Renewable Energy Access: The Utilities of the Future*.](#)



07

Enabling Environment

KEY MESSAGES

- The 2021 UN High-level Dialogue on Energy, alongside the focus on delivering a clean and just energy transition for all at COP26, elevated the global profile of the OGS sector
- While at least 12 countries completed the development of their electrification plans over the last two years, only a few governments are adopting and implementing them at a pace that matches ambitious targets
- Greater recognition of the importance of OGS has led to new programs and a widening of scope by some governments and development partners. This includes a focus on productive use, powering healthcare and ensuring that no one is left behind in the clean and just energy transition

7.1 OGS in the International Agenda



The 2021 UN High-level Dialogue on Energy, alongside the focus on delivering a clean and just energy transition for all at COP26, have elevated the global profile of the OGS sector.

The High-level Dialogue on Energy, convened by the UN Secretary-General in September 2021 was the first gathering of world leaders in over 40 years at the UN solely focused on energy issues, attracting participation from 100+ Member States. The dialogue delivered a roadmap with recommended actions and milestones to achieve SDG7; alongside voluntary 'Energy Compact' commitments from states and other stakeholders convened by SEforALL. On behalf of the OGS industry, GOGLA submitted a Compact to 'Power 1 Billion Lives' by 2030 through increased access to solar kits and productive use of energy (PUE) products.⁴⁰⁴ The compact is endorsed by over 100 organizations and various governments including Ethiopia, Kenya, Malawi, Uganda, Nigeria and the Democratic Republic of Congo. Ethiopia, India, Nigeria, Zambia and Bolivia have also developed their own energy compacts which have incorporated OGS to drive the universal electricity access agenda.

404 [GOGLA \(2021\), Powering 1 Billion Lives Energy Compact.](#)

405 [Efficiency for Access \(2022\), Co-theme lead for Energy Access at new COP Resilience Hub.](#)

406 [United Nations Framework Convention on Climate Change Secretariat \(2022\), Nationally Determined Contributions Registry.](#)

In November 2021, the United Kingdom and Italy co-hosted the 26th UN Climate Change Conference (COP26) in Glasgow, where developing countries emphasized the need to respond to climate risks without compromising their development agenda. Beyond electricity access, governments and other stakeholders are increasingly recognizing the potential of off-grid solutions as a tool for reducing CO₂e emissions whilst building climate resilience. For the first time, an SDG7 pavilion was hosted, which highlighted the opportunities and approaches for delivering a just and clean energy transition using renewable electricity solutions. OGS was profiled as a key solution. Efficiency for Access became the co-theme lead for electricity access in the newly created COP Resilience Hub, to increase the focus on helping people cope with the impacts of climate change.⁴⁰⁵ These initiatives elevated the profile of OGS on the world stage for its potential to address the issues of electricity access, climate resilience and range of other development challenges, while helping to drive action at national levels.



33 countries have included off-grid solar solutions in national climate change mitigation plans, while five have included it in adaptation measures.

Between 2020 and 2022, at least eight countries seeking to meet and or surpass their climate change commitments either updated or revised their nationally determined contributions (NDCs) to include increased access to off-grid electricity solutions, taking the total to 33. These included Bangladesh, Pakistan, Nigeria, Malawi, Mozambique, Ghana, Rwanda and Ethiopia.⁴⁰⁶ As part of its climate mitigation measures, Nigeria aims to increase off-grid renewable energy generation to 13 GW by 2030,

of which at least 2.7 GW will be solar home systems and solar street lights,⁴⁰⁷ whilst Ethiopia's proposed climate adaptation measures plan to increase the use of off-grid energy solutions in rural areas.⁴⁰⁸ NDCs are the foundation of the Paris Agreement and embody efforts by each country to reduce national emissions and adapt to the impacts of climate change.

The inclusion of OGS in National Adaptation Plans of Action remains more limited, with only five countries including it. This includes Nigeria, which also supports the adoption of solar energy in its Ebonyi, Kaduna, Gombe, Bauchi, Delta and Lagos state adaptation plans.⁴⁰⁹ However, a better understanding of the impacts of OGS on adaptation and resilience is needed for this to become a central part of climate change planning for national governments and to stimulate investment by actors focused on climate adaptation.

7.2 Status of Integrated Electrification Plans



Governments recognize the importance of OGS as a viable electrification solution and off-grid technologies have been mainstreamed in electrification strategies and approaches to achieve SDG7.

With just eight years left to achieve universal access, governments are increasingly embracing OGS as a viable electricity access solution. Off-grid solar has become widely acknowledged as the least-cost electrification solution for hundreds of millions of off-grid households (see Chapter 2),

particularly in sparsely populated rural communities. Many governments are including OGS in their Integrated Electrification Plans (IEPs) alongside the national grid and mini-grids; at least 12 more countries completed their IEPs in the last two years.⁴¹⁰ Governments have also increased their efforts to support the deployment of OGS technologies and the scale up of off-grid markets in their countries.

For example, Madagascar has dedicated 30% to off-grid solutions in its IEP. At 33.7% total electrification in 2020, Madagascar is still far from achieving SDG7.⁴¹¹ Given the short time remaining to 2030, Madagascar has allocated a share of 30% to off-grid solutions (20% through mini-grids, 5% through SHS and 5% through solar lanterns) in its electrification plan.⁴¹² The government partnered with the World Bank to launch the Least-Cost Electricity Access Development (LEAD) project to finance cost-effective investments in grid and off-grid infrastructure that leveraged the OnSSET tool to design affordable electrification pathways for the country.⁴¹³ Through the LEAD project, 30,000 households have been electrified with a goal of reaching 100,000 by 2024 through OGS.⁴¹⁴

Mozambique and Nigeria, having launched their IEPs in 2017 and 2019, respectively, are making strides in their implementation to achieve their OGS targets.

- **Mozambique:** With a target of 50% off-grid electrification by 2030 specified in its IEP, the government has rolled out a number of initiatives towards implementing this goal.⁴¹⁵ The BRILHO program was launched in 2019 to support the IEP targets, aiming to reach 1.5 million Mozambicans and 15,000 small businesses through SHS, mini-grids and improved cooking solutions.⁴¹⁶ By October 2021, the program had deployed over 53,000 SHS and provided electricity access to over 306,000 people and 5,000 SMEs i.e., approximately 20% and 33% of the program's population and business targets, respectively.⁴¹⁷ Similarly, the ProEnergia project, approved by the World

407 [Government of Nigeria \(2021\), First Nationally Determined Contribution 2021 Update.](#)

408 [Government of Ethiopia \(2021\), First Nationally Determined Contribution 2021 Update.](#)

409 [Government of Malawi \(2021\), First Nationally Determined Contribution 2021 Update.](#)

410 [Open Capital Advisors analysis.](#)

411 [The World Bank, Access to electricity \(% of population\) - Madagascar.](#)

412 [Reiner Lemoine Institut \(2020\), Draft Version Deep Dive Analysis. WP5: Recommendations to include off-grid RE in the NDC Update 2019, Madagascar.](#)

413 [OnSSET is an energy optimizing tool developed by the KTH Royal Institute of Technology that estimates, analyses, and visualizes the most cost effective electrification strategy.](#)

414 [The World Bank \(2022\), Madagascar - Least-Cost Electricity Access Development Project - LEAD.](#)

415 [GGGI \(2019\), Country Brief: Mozambique.](#)

416 [SNV \(2021\), Government of Mozambique Approves Off-grid Energy Regulation Taking a Key Step Towards Universal Access.](#)

417 [BRILHO \(2021\), BRILHO Programme Celebrates Progress and Welcomes SIDA as a new Donor during Recent Energy Access Event.](#)

Bank in 2019 was initiated to support electrification, including through OGS.⁴¹⁸

- **Nigeria:** The Federal Government of Nigeria is targeting 90% electrification by 2030 and has embarked on a number of projects to achieve their OGS targets.⁴¹⁹ The government launched the Nigeria Electrification Project (NEP) to be implemented by the Rural Electrification Agency (REA), which targets reaching 1 million households and 250,000 SME's through SHS or mini-grids, to provide electricity at lower costs.⁴²⁰ By 2021, the project had provided standalone solar (SAS) systems for 70% of their target of 300,000 households for SAS.⁴²¹ Projects such as the Solar Power Naija project, launched in 2020 with an overall goal of achieving 5 million new connections through either SHS or mini-grids, have played a crucial role in supporting the installation of 100,000 SHS and an additional 200,000 to be supported by the Nigeria Sovereign Investment Authority (NSIA).⁴²²



At least 12 countries completed the development of their electrification plans over the last two years, yet only a few governments are adopting and implementing them at a pace that matches their SDG7 ambitions.

Implementation of OGS electrification is currently under-prioritized due to limited technical skills and implementation capacity of the public and private sector, slowing progress and, in some instances, resulting in the reprioritization of status quo technologies including the grid. There is a clear skills gap for OGS solutions in many public sector electricity access agencies, compared to longer standing experience and education of key members on more traditional power solutions, such as

electricity generation and distribution at grid level. This often affects the implementation of OGS targets set out by IEPs (see Box 21). For example, a number of countries are still lacking dedicated government bodies creating policies, regulations and programs to assist OGS players to serve areas identified as ideal for OGS electrification. As a result, OGS continues to be under-prioritized in planning, budgeting and implementation compared to grid solutions.

Adequate resourcing for electrification plans, and predicting future developments has been challenging.

With off-grid solar markets still relatively new, it is difficult to estimate how quickly they can deliver and which kind of support is required for them to achieve set out targets. For example, even Rwanda, although having one of the fastest rates of electrification on the continent and having successfully developed a Rural Electrification Strategy, is reconsidering the role of OGS in their National Electrification Plan.

The government initially prioritized off-grid solutions but during implementation, realized that OGS markets were not delivering electricity access at the pace that the government initially expected. They are therefore contemplating reducing the targeted OGS contribution from 48% of the population to 30% and increasing its grid targets from 52% to 70% by 2024.

This adjustment of OGS targets is due to delays in the implementation of sector support programs and changing official product standards, but also elements outside the government's control, such as over-optimism in growth projections by the private sector, and under-appreciation of the impact of low levels of ability to pay amongst target beneficiaries and the need for greater demand-side support. To meet new OGS electrification target by 2024, the Rwandan government is launching initiatives to incentivize the private sector to serve the unelectrified population for example, by participating in the Pro-Poor RBF (see Section 7.3).

418 [The World Bank \(2022\), Mozambique Energy For All \(ProEnergia\).](#)

419 [REA \(2022\), The Master Plan.](#)

420 [REA \(2018\), Nigerian Electrification Project Overview.](#)

421 [The World Bank \(2022\), Nigeria Electrification Project.](#)

422 [REA \(2021\), SPN launches the deployment of 100,000 SHS Under ESP; Africa Energy Portal \(2022\), NSIA To Provide \\$24m for Solar Power Naija Programme; Rural Electrification Agency | Solar Power Naija.](#)

Box 21: Challenges faced and lessons learned from implementation of Kenya's NEP

Kenya is one of many examples that illustrates the difficulty of moving from creating an Intergrated Electrification plan, to implementation. Kenya developed its electrification plan in 2015 and officially adopted a national strategy drawing from the plan, the Kenya National Electrification Strategy (KNES), three years later.⁴²³ Although considerable success i.e., 75% electrification in 2021 up from 20% in 2013 can be observed, the implementation of electrification targets through OGS solutions has not been without difficulties. The Kenya Off-Grid Solar Project (KOSAP) is one project that faced challenges during implementation from which lessons learned can be drawn.

KOSAP was designed to drive electrification in 14 high electricity deficit areas through OGS solutions, but may be falling short of achieving this by 2023. The 14 counties include West Pokot, Turkana, Marsabit, Samburu, Isiolo, Mandera, Wajir, Garissa, Tana River, Lamu, Kilifi, Kwale, Taita Taveta, and Narok. While 20% of the population live in these areas, they are also the least dense counties, accounting for 72% of the country's total geography, making it substantially more costly for OGS companies to serve these customers. To encourage OGS companies to extend their services to the target counties, KOSAP launched an RBF scheme as an incentive. While the program was set up with the best intentions in mind it had only achieved 28% of its standalone solar systems target approximately 4 years since the approval of the program.⁴²⁴

Despite being able to electrify ~200,000 people through OGS solutions under KOSAP, the project experienced implementation challenges that provide helpful lessons for other countries. Implementation challenges of the KOSAP program that likely led to the slow progress include complex administrative processes and, and incentives that may not have been appealing to OGS companies.

1. Delays in contracting companies, agents verifying RBF results, and validating results as well as delays in disbursing incentive payments to OGS companies are some of the administrative challenges.⁴²⁵
2. KOSAP targeted counties with low electrification rates and low income. For sparsely populated communities, per-company targets may not have been optimal for OGS companies to prioritize distribution to the identified areas, as opposed to markets they already operate in.

Outside of KOSAP, other challenges that may have affected the project's progress, like changing key policies, may have disincentivized some companies. The Government of Kenya revoked OGS VAT exemptions in 2020, to comply with national fiscal policy to raise revenue and gradually eliminate tax exemptions, leading companies to focus their operations on more commercially attractive markets.

Considering this, there are general lessons to be observed including: Program designs should reflect implementing agencies' capacity. Program implementers should adequately plan and budget to ensure smooth execution of OGS programs. This includes, but is not limited to: putting in place suitable incentives; ensuring that team skill, size and capacity are well accounted for; incorporating the right systems to track progress, and finally, making disbursements accordingly to avoid delays in implementation. RBF managers should also ensure that streamlined and efficient verification agents are contracted early enough, preferably before the program starts; this will reduce delays in claims settlements and the resulting impact on company cash flows.

Implementation challenges experienced by governments have increased initiatives to execute lessons learned, assist governments to effectively plan for electrification and implement electrification plans. These initiatives include:

- **Technical assistance (TA):** several countries collaborate with development partners for technical assistance with best implementation practices apart from financing

for off-grid solutions. For example, the World Bank partly funded the Regional Off-Grid Electricity Access Project (ROGEAP) launched by ECOWAS in 2021 that includes a technical assistance component offered to key stakeholders, such as the governments and OGS companies in the region, to help accelerate the rate of OGS sector development.⁴²⁶ Public sector TA for example, focuses on supporting governments to adopt

⁴²³ [Ministry of Energy, The World Bank \(2018\), Kenya National Electrification Strategy: Key Highlights 2018.](#)

⁴²⁴ [World Bank \(2022\), Off-grid Solar Access Project for Underserved Counties.](#) Note: data from Results Framework: Intermediate Results Indicators (households provided with new electricity connections by stand-alone systems) as at September 30, 2021; accessed on July 4, 2022; [USAID's Power Africa Off Grid Project \(2019\), Off-grid solar market assessment: Kenya.](#)

⁴²⁵ [Open Capital Advisors consultations.](#)

⁴²⁶ [Dalberg \(2021\), Commercial & Economic Feasibility Study for Enhancing Off-Grid Solar Inclusion in Sub-Saharan Africa.](#)

and implement national policies and regulations that boost OGS sector growth and further deployment of OGS solutions.⁴²⁷

- **Development partners collaborations to launch funded projects:** some governments are working with development partners to establish national programs that include funding commitments and capacity building. For example, the government of Ghana worked with the World Bank and the AfDB, and engaged other stakeholders to develop the the Scaling-up Renewable Energy Program in Ghana Investment Plan (SREP-Ghana IP) in 2015. The program aimed to accelerate electrification through renewable energy solutions across three projects, with the first involving standalone solar solutions. The World Bank was a project design and implementation partner and the AfDB, the lead multilateral development bank for

the first project, signed a debt agreement of \$69.88 million funding in 2022 for implementation from 2022 to 2025.⁴²⁸ The Mwindu Fund, a renewable energy RBF launched in the DRC, is another example of an initiative that was designed to attract funding from multiple donors.⁴²⁹

- **Knowledge-sharing:** development partners are creating platforms and forums for governments to share ideas, experiences, and lessons learned from challenges faced during program implementation. One example is a network of representatives from African government energy ministries and regional bodies named the ‘Community of Champions’ that facilitates peer-to-peer knowledge sharing (see Box 22).⁴³⁰ Benefits such as improved implementation strategies for OGS are expected to result from the ‘Community of Champions’.

Box 22: The Community of Champions: A growing and evolving network

The Community of Champions is a platform established in 2018 with the support of the World Bank/ESMAP, Shell Foundation, Power Africa, Africa Clean Energy, Sustainable Energy for All and the Africa Enterprise Challenge Fund. The platform facilitates peer to peer learning between governments and exchange of ideas, challenges, successes, and best practices related to scaling up off grid electricity access through integrated energy approaches for public sector energy access champions.

It also enables a dialogue between governments, the private sector off-grid solar industry, and development partners / relevant stakeholders to co-create an enabling policy environment for the realization of universal energy access across sub-Saharan Africa.

Five additional countries, DRC, Liberia, Mozambique, Somaliland and Zimbabwe, have joined the Community since 2020, taking the total to 24 national governments and three regional organizations spread across sub-Saharan Africa.⁴³¹ Increased membership is driven by continued and growing interest in OGS by national governments. Discussions have also expanded to include topics such as PUE, job creation, consumer protection and COVID-19 response.

Availability of funding besides faster upskilling is needed to achieve SDG7. While some countries are working towards implementing their IEPs, launching programs to support OGS sector development, the pace of implementation remains slow. Besides upskilling and

implementation support, it is imperative that more funding be made available more conveniently for well-intentioned electrification strategies to be actioned according to planned timelines to achieve SDG7.

427 [ROGEAP \(2020\), Regional Knowledge Sharing And Technical Assistance For Integrated Electrification Planning And Strategy Improvement.](#)

428 [Climate Investment Funds \(2015\), SREP Investment Plan For Ghana; Afrik21 \(2022\), GHANA: Government Secures \\$70m For Off-Grid Solar Electrification.](#)

429 [World Bank IDA \(2022\), Project Appraisal Document On A Proposed Grant In The Amount Of Sdr 215.6 Million \(\\$300 Million Equivalent\) And A Proposed Credit In The Amount Of US\\$300 Million To The Democratic Republic Of Congo For An Access Governance And Reform For The Electricity And Water Sectors Project; Elan RDC, Sector Overview - Renewable Energy.](#)

430 [GOGLA \(2022\), Community of Champions.](#)

431 *Ibid.*

7.3 Sector Development and Support Programs



New programs and a widening of scope by governments and development partners has led to more focus on productive use, powering healthcare and ensuring that no one is left behind in the clean energy transition.

Governments and development partners are recognizing the potential of off-grid solutions to power healthcare, productive use and agriculture, and are increasingly focused on bridging the ‘affordability gap’ for the poorest and most vulnerable households, impacting the focus of

their programming. For example, the World Bank/ESMAP Lighting Global program has expanded its remit to include PUE technologies such as solar water pumps, mills and sewing machines. ESMAP will also contribute to human capital development by supporting electrification of public health centers and schools. As World Bank’s activities are driven by government demand, this illustrates the evolving interest of national leaders.

Between July 2015 and June 2022, World Bank programs which include OGS have been approved in more than three quarters of the countries in sub-Saharan Africa. Including technical assistance (TA), the total amount committed to accelerating adoption of OGS since July 2015 is over \$2 billion (Figure 60). The chart below includes funding allocated to off-grid solar standalone solutions, including residential, productive uses, and public institutions. Several activities supporting the off-grid solar market development are carried out under the TA components, such as consumer awareness campaigns or market intelligence. However, the TA funding is not exclusively allocated to off-grid solar and also supports other project objectives, such as strengthening the utilities or enhancing the capacity of governments.

Figure 60: World Bank funding for off-grid solar between July 2015 and June 2022⁴³²

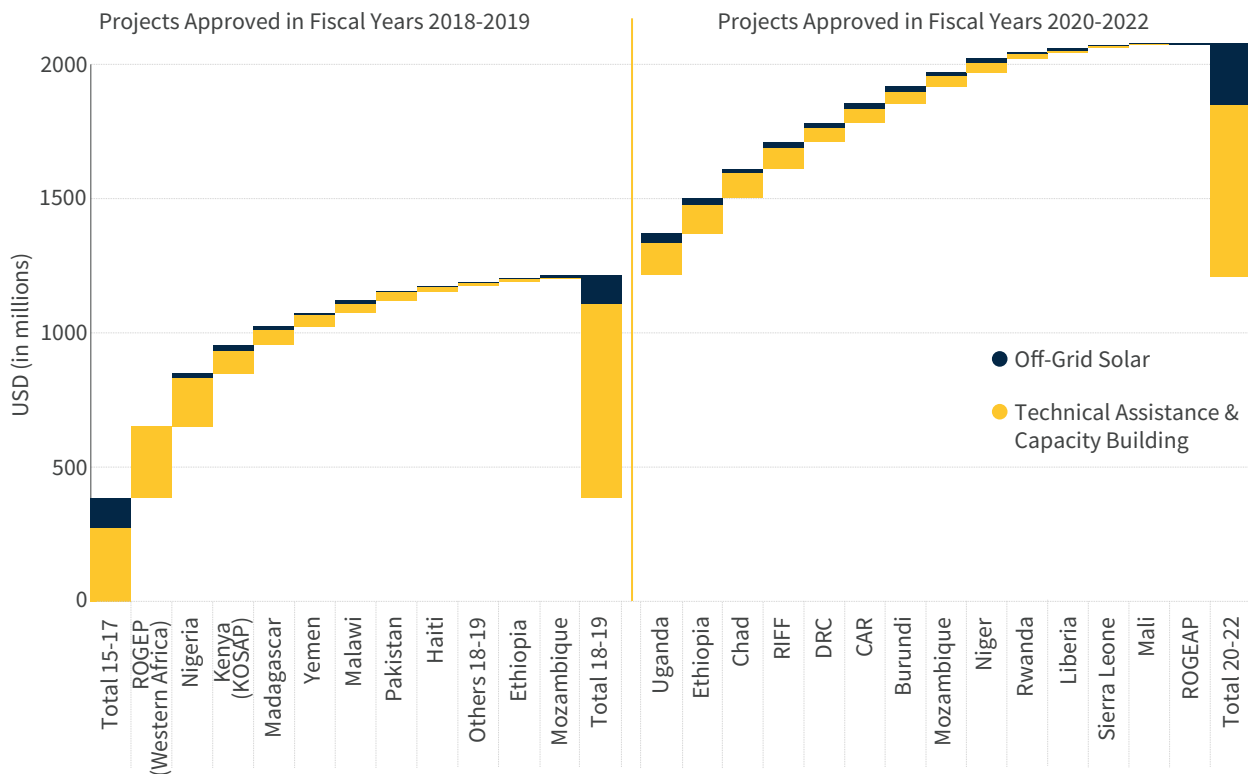

⁴³² GOGLA analysis. Please note that fiscal years run from July-June.

Of the \$2 billion committed by the World Bank since July 2015, more than \$470 million in specific support for OGS and \$160 million in related TA has been approved since 2020. The 14 energy access projects benefiting from this funding include:

- **Rwanda - Pro-Poor RBF:** Providing an additional \$30 million to support implementation of a pro-poor RBF program that offers an end-user subsidy for SHS. In recognition that, even in mature markets like Rwanda, additional support is needed to reach the lowest income households.
- **DRC - AGREE:** The Access, Governance and Reform for the Electricity and Water Sectors project will provide support to DRC's Mwindi's fund, building on and expanding an RBF program established under the previous World Bank operation, as well as other supportive measures to develop the country's mini-grid and off-grid solar sector.
- **Ethiopia - ADELE:** Under the Access to Distributed Electricity and Lighting in Ethiopia project, a \$50 million off-grid solar component will provide access to finance in both foreign exchange and local currency, as well as an RBF for SEK and PUE products. The project aims to further increase market intake and support expansion of the supply chains in rural areas. It also includes a \$55 million component on the electrification of public facilities.
- **Several FCV affected country projects:** A new wave of recently approved projects focuses on connecting the hardest to reach in nascent markets with high levels of fragility, conflict and violence. This includes the Chad Energy Access Scale Up Project, approved in 2022 with \$93 million allocated to OGS, the Niger Accelerating Electricity Access Project with \$35 million allocated towards OGS and the Central African Republic Electricity Strengthening and Access Project, with a \$50 million OGS component.

In addition, several World Bank programs approved in 2018-19 came online, such as the \$240 million Regional Off-Grid Electricity Access Project (ROGEAP), covering 19 countries⁴³³ in West Africa and the Sahel, and the \$350 million Nigerian Electrification Project supporting mini-grids and OGS (see Box 7).

Other development partners have also broadened their scope and/or continued their support for improving

health, PUE and climate-smart agriculture outcomes. For example:

- Launched in 2021, EnDev and the IKEA Foundation are co-funding a three-year Sustainable Energy for Smallholder Farmers (SEFFA) program (\$8.1 million) to support application of PUE appliances, including cooling, across dairy and horticultural value chains in Kenya, Uganda and Ethiopia.⁴³⁴
- The Water and Energy for Food project (WE4F) that aims to increase food production along the value chain through a more sustainable and efficient usage of water and/or energy.⁴³⁵
- In 2021, the Global Energy Alliance for People and Planet (GEAPP), a \$10 billion clean energy initiative was launched. This is expected to lead to significant new funding being targeted at PUE and job-creation, as well as new and influential organizations entering the OGS space. GEAPP is led by The Rockefeller Foundation and has been developed in partnership with the Bezos Earth Fund, IKEA Foundation and other leading foundations, international finance corporations and multilateral development banks. The initiative focuses on economic productivity and larger SHS and PUE products.
- At COP26, the Transforming Energy Access Programme, funded by UK Aid, was given a £126 million extension. It continues to have job creation and the productive use of energy as objectives. It now also contains a 'leave no one behind' component that focuses on reaching the poorest households and people living in humanitarian settings, which includes health.
- In 2022, the Low Energy Inclusive Appliances research and innovation programme, funded by the IKEA Foundation and UK Aid, received a three-year extension. Its focus on appliances has also led to strong emphasis on productive use and health.
- In 2022, USAID/Power Africa announced a new public and private sector alliance that plans to electrify 10,000 healthcare facilities in sub-Saharan Africa. This brings together partners from the energy access space, such as SEforALL, Shell Foundation and We Care Solar, alongside predominantly health-focused organizations, such as GAVI, UNICEF and World Vision. The alliance creates foundations for the two sectors to drive progress together.⁴³⁶

433 *Benin, Burkina Faso, Cape Verde, Gambia, Ghana, Guinea, Guinea Bissau, Cape Verde, Ivory Coast, Liberia, Mali, Niger, Nigeria, Senegal, Sierra Leone, Togo, Cameroon, Central African Republic, Chad and Mauritania.*

434 *EnDev (2021), Sustainable Energy for Smallholder Farmers (SEFFA).*

435 *Water and Energy for Food (2022), Homepage.*

436 *USAID/Power Africa (2022), USAID's Power Africa Launches Partnership to Electrify Health Facilities Across Sub-Saharan Africa As Part Of President Biden's Global Infrastructure Initiative.*

- Initiatives in multiple countries are under development or have been developed to electrify health centers and/or provide greater storage for vaccines, as noted in Section 3.2.1.

Many governments and development partners are increasing efforts to reach homes and businesses most at risk of being left behind in the clean energy transition.

As well as the growing focus on OGS for FCV countries, several countries are exploring, or implementing, end-user subsidies (EUS) to lower the price of OGS technologies for low income households (solar energy kits) or smallholder farmers (solar water pumps). After initial reticence due to their potential to distort markets, the OGS industry also changed its position to support EUS. ESMAP/World Bank, ACE-TAF, EnDev and GOGLA have developed an [End User Subsidy Lab](#), to promote and study smart EUS design to ensure that future programs can best reach the poorest, whilst supporting sustainable market growth. More details on EUS, as well as current and future programs are explored in Section 8.2.1. A comprehensive overview of different public funding mechanisms can also be found in the recently released report, [Designing Public Funding Mechanisms in the Off-Grid Sector](#).

7.4 Fiscal Incentives



More governments are offering VAT and tax exemptions for OGS, including solar water pumps. However, implementation is inconsistent.

Since 2020, Senegal, Mali, Benin and Liberia joined other countries in sub-Saharan Africa⁴³⁷, and more around the globe, in providing VAT or duty exemptions for solar energy kits and components, while several countries have expanded border tax exemptions to productive use technologies. Mali, Senegal and Sudan included solar water pumps (SWPs) in their exemptions and Liberia exempted SWPs amongst a full range of other solar equipment and

DC appliances. Similarly, Togo's CIZO program provides border tax exemptions for SWPs from eligible providers. This illustrates growing recognition by governments of the role that PUE technologies can play in boosting climate smart agriculture and could lead to a greater adoption of exemptions for PUE across the continent.

Despite this progress, border tax laws can be unpredictable, creating uncertainty and risk for companies and investors. The last few years have seen examples of changes in both the laws themselves, and in their interpretation, often at short notice. For example:

- Kenya unexpectedly re-introduced 14% VAT on solar equipment including batteries in June 2020, increasing this to 16% in January 2021⁴³⁸, before then reintroducing some elements of the exemptions later in 2021.⁴³⁹
- In 2020, companies in Zambia received tax bills covering imports that had occurred in previous years due to an amendment to the regulations in 2019 that clarified that previous exemptions were not applicable.⁴⁴⁰
- In April 2022, Ethiopia's authorities began enforcing a 15% import duty on solar lanterns and SHS in a country where these technologies, alongside solar pumps, had been exempted from import duty, excise duty and surtax for more than a decade.⁴⁴¹

Adding to this unpredictability, implementation of exemptions often remains inconsistent. In some countries, the ability to avail of tax exemptions can vary from company to company, or even shipment to shipment. However, efforts to simplify customs procedures are emerging. For example, in 2020 and 2021 ACE TAF developed importation guides in Kenya⁴⁴², Senegal⁴⁴³, Zimbabwe⁴⁴⁴ and Nigeria⁴⁴⁵ in collaboration with customs authorities to provide clarity on importation processes and the tax exempt status of OGS products. The national renewable energy associations in East Africa, with the support of the UK's FCDO funded PowerUp! program, also developed a Taxation Handbook for the East African Community which was launched on 7th July 2022.⁴⁴⁶ Ongoing support for customs authorities in the implementation of VAT and tariff exemptions, for example within future programs and capacity building initiatives,

437 [Power Africa, GOGLA \(2022\), Off-grid VAT and Duty Tracker.](#)

438 [Government of Kenya \(2020\), Finance Act 2020.](#)

439 [Government of Kenya \(2021\), Finance Act 2020.](#)

440 [GOGLA consultations.](#)

441 [Ethiopia Ministry of Finance \(2021\), Customs Tariff Amendment.](#)

442 [Africa Clean Energy \(2019\), Importation Guidelines For Solar PV Products and Systems in Kenya 2019.](#)

443 [Africa Clean Energy \(2021\), Sénégal – Elaboration de la Stratégie Genre et Inclusion Sociale \(GESI\) du PANGE.](#)

444 [Africa Clean Energy \(2021\), Customs Handbook for Solar PV Products in Zimbabwe.](#)

445 [Africa Clean Energy \(2021\), Importation Guide for Solar PV Products and Technologies in Nigeria 2020.](#)

446 [National Renewable Energy Associations in East Africa \(2022\), The East African Regional Handbook on Solar Taxation](#)

will continue to ease doing business for OGS companies, ultimately supporting electrification efforts.

Efforts to update and clarify HS Codes for OGS technologies are also a step in the right direction but more focus is needed on harmonization and standardized application. Many OGS products are not well defined under the current Harmonized System (HS Codes), the numerical method used by customs officials in classifying and assessing duties and taxes for traded products. In 2022 updates to the HS Codes, the World Customs Organization created new subheadings for a range of off grid products that were previously left out or not well defined.⁴⁴⁷ However, there are still inconsistencies and persistent differences in the application of HS Codes by different countries remains a challenge. For example, in 2021 solar lanterns in Malawi were unexpectedly reclassified to a new HS code without any accompanying change in law, resulting in new duties becoming applicable and causing significant delays in the clearance of imports.⁴⁴⁸

7.5 Industry Regulations



While the prospect of regulations on PAYGo grows, the appropriate regulatory framework remains uncertain.

The PAYGo sector is currently operating under laws or regulations applicable to the broader retail or rent-to-own sector. However, companies increasingly offer financing to customers, and governments are exploring appropriate ways to implement additional regulation. For example, as part of its broader efforts to protect consumers and regulate the provision of consumer credit in the country, Tanzania enacted the Microfinance Act in 2018, followed by publication of regulations in 2019 to enforce activities of the new law. While the primary objective was relatively clear, regulating the provision of all credit, including activities of non-deposit taking microfinance service providers, the new law and regulations proposed to treat all entities affected as financial institutions. An analysis of the Tanzanian regulations indicated that OGS sector players whose core business could include the development, import and sales of OGS products in addition to offering PAYGo solutions to customers, would be treated as financial institutions and require additional levels of authorisation for their operations. This would

have included opening new stores, expanding into cross border markets and importing products.

In 2022, Kenya enacted The Central Bank of Kenya Digital Credit Providers (DCP) Regulations to provide for the licensing and oversight of previously unregulated Digital Credit Providers. They were intended to regulate the manner in which DCPs would conduct their business, including provisions on lending, pricing, consumer protection, debt collection and anti-money laundering. As in Tanzania, the potential application to the PAYGo sector would have seen companies fall under the regulatory oversight of both the country's Central Bank and the Energy Sector Regulator.

However, as a result of technical consideration and broad consultation with sector players, the Central Banks of Tanzania and Kenya determined that these proposed regulations were not a fit for PAYGo companies in the OGS sector. While noting that the provision of credit in Tanzania is a regulated activity, the Bank of Tanzania noted that appropriate regulations for the PAYGo sector were yet to be developed and that consultations to determine the most appropriate regulator and regulatory regime would continue. In its case, the Central Bank of Kenya clarified that the DCP Regulations would not apply to credit arrangements incidental to the sale of goods, effectively excluding PAYGo transactions. Looking forward, it is clear that governments, industry and other stakeholders will need to work together to develop appropriate regulatory frameworks for the PAYGo sector, that not only protect consumers, but also provide for the sector's growth and role in the country's energy landscape.



The appropriate handling and disposal of electronic products at their end of life (EOL) is a subject of increasing concern for governments and the industry.

Given the millions of products that have been sold over the last decade, concerns on the appropriate handling and disposal of e-waste have emerged for governments, development partners and the broader industry. Over the last two years, several countries have sought to strengthen their existing waste management laws and regulations to introduce or enhance extended producer responsibilities and address current e-waste management challenges, including from OGS. For example:

⁴⁴⁷ [World Customs Organization \(2022\), Amendments Effective from 1 January 2022.](#)

⁴⁴⁸ [GOGLA consultations.](#)

- Kenya signed into law the Sustainable Waste Management Act in July 2022, and has developed the Extended Producer Responsibility (EPR) regulations covering electrical and electronic equipment that is currently under stakeholder review.
- Ghana has developed a National Electrical and Electronic Equipment (EEE) Management and Control Policy with the objective of establishing an e-waste disposal and to collect and recycle waste in Ghana.
- Tanzania reviewed its 1997 National Environment Policy. Among policy gaps addressed is the inclusion of a dedicated section on management of Electrical and Electronic Equipment waste.
- Nigeria reviewed its 2011 E-Waste Regulations in 2021 to incorporate stand-alone solar products and to mandate that end-of-life management of all OGS waste must be dealt with through a Producer Responsibility Organization specifically authorized to collect it.

Companies will increasingly need to plan for e-waste regulation and build it into their operational plans and processes. It also creates space for innovation and strategic partnerships with other parts of the electronics sector, due to the current lack of e-waste infrastructure in countries with high electricity access deficits. For example, only a few countries in sub-Saharan Africa (including Rwanda, Nigeria, Kenya and South Africa), have e-waste management facilities that are equipped to handle end-of-life products from off-grid solar, and cross-boundary movement is expensive and complex.

7.6 Quality Standards



Countries have increasingly adopted the International Electrotechnical Commission (IEC) quality standards for solar energy kits but capacity constraints hinder effective enforcement.

Protecting consumers from the negative impacts of bad quality products remains a concern. Low-quality products can harm consumers, the environment and the off-grid market. Purchasing a product that breaks easily can waste customer savings, create additional e-waste and erode confidence in OGS technologies. This can have a knock-on impact on sales of OGS by companies that are producing high-quality products, potentially slowing the pace of electrification.

To protect customers from low quality OGS products, the World Bank Group's Lighting Global program developed quality standards for solar kits to drive up, and maintain, a base level of quality within off-grid technologies (see Box 23). These were integrated into the globally recognized International Electrotechnical Commission (IEC) standards in January 2021. The process for national standards bodies to adopt standards for solar energy kits has consequently improved and created greater uptake. Ethiopia, Zambia, Uganda, Zimbabwe, Sierra Leone and Senegal have fully adopted the IEC standards and Nigeria has adopted national standards that are harmonized with the IEC. Tanzania and Papua New Guinea are in the final stages of adopting the IEC standards, while DRC has begun the process. China has adopted the standards on a voluntary basis. In addition, the standards are being used as a measure to ensure quality within a number of intervention programs.

Box 23: VeraSol Quality Assurance program

Launched in 2020, VeraSol is an evolution of the IFC-World Bank Lighting Global quality verification and assurance program. Verasol's current activity areas include:

1. Expansion beyond lighting and solar home systems, with specific QV categories for off-grid solar appliances and for productive use technologies previously under Equip data, including solar water pumps, refrigerators, fans, TVs and electric cookers
2. Continuing work with upstream manufacturers, standards authorities, and testing laboratories in China, to increase voluntary adoption of quality standards on the supply side
3. Integration of the VeraSol quality standards with the internationally recognized IEC test standards, and leveraging this to facilitate adoption of the VeraSol/IEC standards into national regulation on the demand side
4. Providing support to governments in adopting and implementing OGS standards

The IEC has adopted Lighting Global Quality Standards for solar lanterns, multi-light systems and solar home system kits with PV modules rated up to 350 Wp (IEC TS 62257-9-8).⁴⁴⁹ This is a foundation for quality in the OGS sector. VeraSol evaluates products against the newly adopted IEC quality standards and products that meet the IEC quality standards are deemed VeraSol verified. All certified products are recorded in their central database: data.verasol.org⁴⁵⁰

Despite the increased adoption of quality standards for OGS products, several challenges hinder effective implementation. These include:

- **Limited capacity of standards authorities to enforce:** Ensuring compliance to applicable standards requires adequate infrastructure and capacity to undertake market surveillance and enforcement activities.
- **Standards are not tied to fiscal incentives in a majority of countries:** A few countries, including Madagascar, Malawi and Senegal, currently provide VAT or duty exemptions on quality compliant products, effectively lowering the price for consumers. However, such measures to encourage the import and sale of quality verified products have not yet been widely adopted.
- **Introduction of bespoke standards:** In some countries, standards authorities have chosen to introduce national standards that are not aligned with international standards. In India, solar energy kits must conform to national testing standards and certification procedures, not aligned to the IEC standards; while in Rwanda products need to comply with ministerial guidelines that provide additional requirements to the IEC standards. This has resulted in product redesign and additional transaction costs for off-grid solar companies, which are passed on to end users.
- **Standards applied inconsistently to OGS products:** In some countries, international standards are required for some products but not others. For example, in India, enforcement of standards do not cover the full range of off grid technologies, as products less than 20 watts are exempt from testing certificates.

There has been progress in the development of accompanying measures to enforce compliance to quality standards. For example, a joint initiative by the International Finance Corporation (IFC), VeraSol and ACE TAF between 2020 and 2022 built the capacity of market surveillance solar test laboratories by training personnel and upgrading lab equipment in Zambia, Nigeria, Kenya and Ethiopia. However, capacity building and surveillance infrastructure in other regions is still needed to ensure that quality products are reaching consumers and providing reliable electricity access.

While efforts to protect customers from low quality products are key, it is worth noting that recent research on consumers' experiences with off grid solar products in Kenya found that some cheaper non-quality verified solar lanterns and home systems still provide a relatively high level of service. However, the study also found that, for many other non-quality verified products, the lower cost also translates into a lower level of durability, reliability and/or output; with significantly higher proportions of non-quality verified solar lanterns (19%) and SHS (31.3%) breaking down compared to quality verified ones (9.2% and 8.9%, respectively). Non QV products also lacked meaningful warranties and any recourse to replacement, aftercare or complaints processes. Further studies to develop a better understanding of these products, which are often developed and deployed outside the affiliate market, could help to uncover insights on affordability and customer-choice.



Although PUE technologies are in early technology and market development stages quality standards are emerging for solar water pumps, cooking and cooling appliances.

Although PUE technologies are at an earlier stage of development, with wide variations in their technology configurations and a more limited availability of performance data, the development of international quality standards, Minimum Energy Performance Standards (MEPS) and test methods for some PUE technologies are underway. For example:

- Under the VeraSol Program, quality standards for refrigerators are currently under public review, while test methods for solar water pumps and pressure cookers are available.⁴⁵¹
- India is also developing its own test methods for solar water pumps.
- The UN Environment Program's (UNEP) United For Efficiency (U4E) Initiative is also in the process of

449 [World Bank, Lighting Global \(2020\), Summary of Requirements in IEC TS 62257-9-8:2020.](#)

450 [VeraSol \(2022\), Product Database.](#)

451 [VeraSol \(2022\), Draft Quality Requirements for VeraSol Certification of Off-Grid Solar Refrigerators.](#)

developing model regulation guidelines designed to help governments with the deployment, adoption and enforcement of energy efficiency regulations for refrigerators. These guidelines contain essential elements, including product scope, definitions, test methods, minimum efficiency levels and a set of minimum performance requirements. They are accompanied by market surveillance measures to ensure consumers can purchase quality efficient products with confidence.

- MEPS for energy efficient cooling appliances are at different levels of implementation. In February 2021, out of the 21 countries in the South African Development Community (SADC) and East African Community (EAC) regions, four countries including Kenya, Mauritius and South Africa had mandatory MEPS in place and three (Uganda, Rwanda and Seychelles) had voluntary MEPS for refrigerators.⁴⁵²

U4E, in collaboration with the East African Centre of Excellence for Renewable Energy and Efficiency (EACREE) and SADC Centre for Renewable Energy and Efficiency (SACREEE) also commissioned market assessment to inform the development and adoption of harmonized MEPS and energy labels in EAC and SADC regions. Comprehensive quality standards for some earlier-stage PUE products may be premature, as their capacities and configurations are still being developed. Guidelines, minimum efficiency standards and common test methods create the foundations to ensure good service to customers and for universal standards in future.

7.7 Supply Chain, Local Manufacturing and Assembly



As the industry grows there is pressure to improve the sustainability of the supply chain through increased transparency of solar PV module manufacturing.

Manufacturing advancements and supply chain efficiencies have brought high quality and affordable solar technology within reach for the world's poorest people. However, the industry has a broader responsibility in sustainability to manage the full range of social and environmental impacts in the supply chain. A particular concern is the human rights of workers in the production of PV modules following reports that provide evidence of violations against the Uyghur ethnic group.⁴⁵³

The PV module supply chain has multiple steps that are spread across multiple locations and many companies. The forced labor concerns center around the first step in the chain; the approximately 45% of the world's solar-grade polysilicon supply that comes from manufacturers in Xinjiang. Off-grid solar manufacturers buy a finished PV module from a supplier – none of which are based in Xinjiang. It is, however, virtually impossible to track the provenance of materials from source to finished product due to the complex supply chain and lack of traceability.⁴⁵⁴

A group of 12 multilateral development banks, led by the IFC, is developing more rigorous procurement processes and a framework for collective action. It is recognised that the off-grid solar sector has minimal leverage in the supply chain, representing only 0.06% of the global PV industry.⁴⁵⁵ Nonetheless, it is expected that additional requirements will be made by development banks in the push for increased transparency and traceability.



While some governments are eager to increase local manufacturing and assembly, the underlying conditions are not yet developed enough to support this in most high electricity access deficit countries.

National governments are increasingly interested in the potential for job creation, reduction of imports and forex savings that can be gained through local manufacturing and assembly of products, including those for the off-grid sector. COVID-19 and the accompanying supply chain disruptions has raised concerns in the private sector about security of supply, creating an interest in exploring

⁴⁵² U4E (2021), *Overview of the Market on Refrigerating Appliances and Room Air Conditioners in East and Southern Africa*.

⁴⁵³ Murphy and Elima (2021), *In Broad Daylight: Uyghur Forced Labour and Global Solar Supply Chains*.

⁴⁵⁴ The Solar Energy Industries Association (SEIA) – a US industry association of large solar players – has developed a rigorous Traceability Protocol and Buyer's Guide. This is not appropriate for small companies and the off-grid sector, though offers an insight into what a scaled-down approach may entail.

⁴⁵⁵ 70 MW / 127,000 MW = 0.06%. GOGLA analysis based on data collected for the *Global Off-Grid Solar Sales and Impact Reports 2016-2021* and IRENA (2021), *World Adds Record New Renewable Energy Capacity in 2020*.

alternatives for local sourcing or production. Despite this, a 2021 ACE TAF report to explore localizing the supply chain in the short to medium term in Nigeria, Ethiopia, Zambia, Tanzania and Rwanda, revealed that the potential for local assembly or manufacturing of OGS products is restricted by challenges including:

- Import tariffs that minimize the economic advantages of local assembly.
- Lack of quality standards for locally assembled products.
- Lack and/or inefficient implementation of incentives.
- Uncertainty around off-take of OGS products.

The report recommends that governments interested in establishing local manufacturing take a staged approach, and ensure that the local base for assembly or manufacture is established before they put in place policies to prioritize locally made products. This will avoid delays to electrification efforts due to the disincentivization of companies that currently supply off-grid technologies and maximize the number of local jobs that can be created within the supply chain, including in sales, management, after-sales support and repair (see Section 3.2.3).

Several national governments of high energy access deficit countries are striving to address the barriers to the local assembly of OGS products, with several initiatives emerging in the past two years. These include:

- LAGAZEL's Benin Zawoue project (see Box 24).
- The Solar Power Naija (SPN) scheme in Nigeria: designed to expand local solar manufacturing capacity and create 250,000 new jobs. The scheme supports the financing of upstream companies dealing with manufacturing and assembly of off-grid value chain components, such as solar panels, inverters, and batteries.
- India's Production Linked Incentive (PLI) scheme: providing an incentive for setting up manufacturing facilities (including for OGS) in India by giving a direct payment amounting to a 4-6% subsidy on the incremental sales of goods manufactured in India. The Financial Budget of India, 2020, includes a specific budget for the solar manufacturing sector.
- Solar module maker, Faso Energy, in collaboration with Spanish equipment provider Mondragon, began to manufacture modules at a factory in Ouagadougou, Burkina Faso, with a capacity of 60-100 PV panels per day. Faso Energy secured about \$1.8 million worth of tax exemptions during construction of the \$5.8 million facility.

Box 24: The Benin Zawoue project: Solar energy kits made in Benin by LAGAZEL

Local initiatives can play an important role in developing products and business models suited to local conditions, creating jobs and building local skills, and ensuring sustainable end-of-life processes.

The French-African manufacturer, LAGAZEL launched an assembly unit for solar kits in Benin in October 2021. The establishment of this second production unit, after its first plant in Burkina Faso, is part of its objective to set up five manufacturing workshops in Africa within five years to produce a target of more than one million solar products. With an installed capacity of 100,000 units per year, but current target annual production of 20,000 units during the first two years of operation is well within this. 95% of components are imported from France and China, with the latter supplying solar modules and batteries. An investment of \$1.1 million in co-financing from the Millennium Challenge Account (MCA-BENIN II) under the Off-Grid Clean Energy Facility (OCEF) and tax exemptions of construction and materials for the plant have been pivotal to project development.

To date, the Benin project has contributed to the creation of twelve jobs. LAGAZEL is also looking to source packaging materials and assemble battery packs and solar panels locally. However, despite establishment of this production facility, LAGAZEL still faces challenges of strong competition, at the local level, due to the presence of many cheap products of poor quality. In addition quality certification processes are more suited for bigger manufacturers with centralized production. Small or decentralized producers like LAGAZEL face challenges including lack of access to local facility inspectors, and IEC testing in West Africa adding compliance and certification costs.

Regarding PUE technologies, Ecolife in Uganda and InspiraFarms, Solar Cooling Engineering, Sun Transfer and Soko Fresh in Kenya are also at different stages of piloting pre-design and local assembly of containerized component solar walk-in cold rooms for cooling fresh agricultural produce. This was driven by the availability of cheap materials for the containerized structure, the ease of construction and the advantages that local assembly

brings for tailoring cold rooms to customer specifications. However, it will take years before cooling units including compressors and energy components, such as charge controllers and inverters which are integral parts of a cold room, can be locally assembled given the high level of skill required. Still, this illustrates the potential for some, lower tech, OGS products or component parts to be locally assembled in the short to medium term.



08

**Funding
Flows**

KEY MESSAGES

- The off-grid solar sector has attracted \$2.3 billion of capital to date. The sector is bifurcated in two streams: 7 scale-ups that are attracting larger ticket sizes through a later stage investor base and over 150 companies that are in their seed or start-up phase
- The 7 companies in scale-up phase are solidifying their market position through their ability to attract capital, diversification of their investor base and access to increasingly higher ticket sizes
- Investment volumes in start-up companies were negatively affected by the pandemic, slowing down their growth. Early stage equity and debt remain a critical barrier to industry growth
- The challenge of reaching the poorest has led to greater focus on funding via results-based financing (RBF) and an emerging interest in end-user subsidy schemes. To date, over \$211 million has been disbursed or is currently disbursing through RBF since 2013
- New types of capital are coming to market with the potential to scale-up the industry: climate finance, local currency, and blended instruments
- A wide range of financiers (agriculture, climate and infrastructure, among others) have shown interest in productive use of energy (PUE) companies, and although the majority of these companies are in the early stages of capital attraction, several capital providers are showing their willingness to invest

8.1 Investment Flows

Companies in the off-grid solar sector finance operations with grant⁴⁵⁶, debt, or equity financing at different growth stages. Besides customer revenue, off-grid solar companies also draw on other revenue streams for

business viability including publicly-funded subsidies. Other emerging revenue streams for the off-grid sector, although largely unexplored, include carbon finance and Distributed Renewable Energy Certificates (DRECs). Figure 61 highlights the different investment and revenue streams that will be profiled in this chapter.

Figure 61: Investment sources and revenue streams in the off-grid solar sector

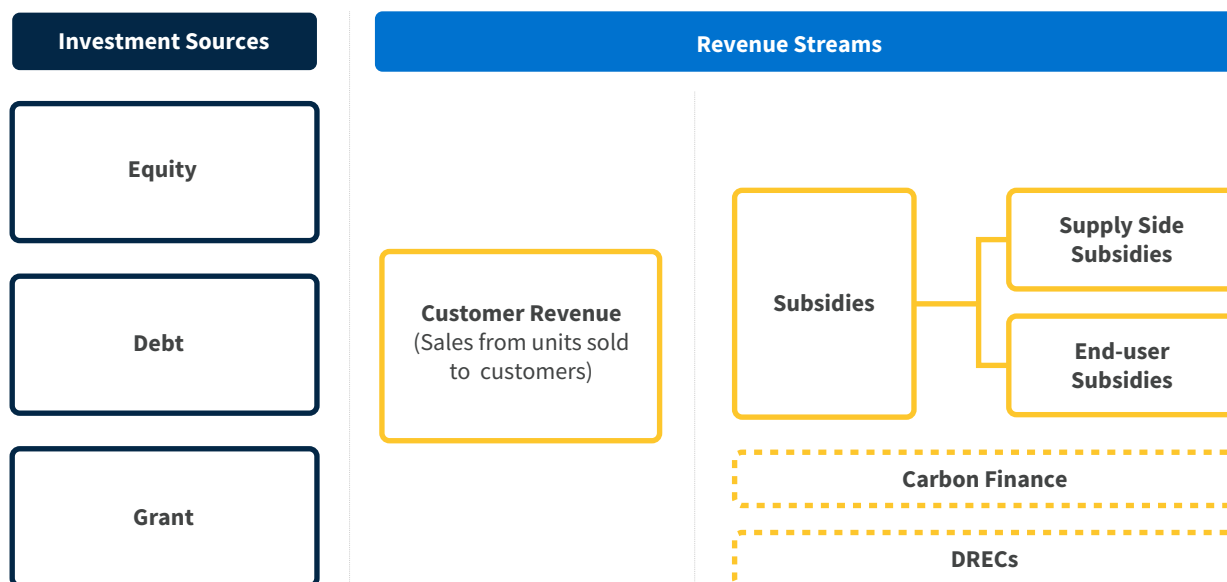

456 Notes: [1] Grants are considered an investment and included at GOGLA Investments Database while Subsidies and Results Based Financing (RBF), are considered a market incentive and as such, accounted separately, [2] Grants generally act as a concessional investment stream, and similar to other types of investments such as angel investments or early stage equity, they give the investor/donor a recourse over the company, albeit usually never repaid. Grants should aim at catalyzing more commercial capital and be coordinated with subsequent investors, [3] Results Based Financing (RBFs) are dependent on the verification of sales, acting effectively as a subsidy to the purchase of goods or services delivered by the awarded companies during a period of time within a specifically designated geography to boost revenues for otherwise non commercial markets. This generates revenue for the company for sales they have already delivered or will be delivered in the short term, i.e. the funding comes upon sales / after verification of sales. However, it does not provide pre-sale financing (i.e. investment) like a grant would do, [4] Some new RBF structures are quite similar to grants in timing and use, and some grants are aimed at geographical expansion, which makes the difference between some RBFs and grants blurry.



In 2021, the off-grid solar sector surpassed \$2 billion in total financing commitments since 2012 (equity, debt and grant). Investment volumes grew by 44% from 2020 to 2021, a strong return to growth after five years of flat annual investments.

From 2012 to 2021, the off-grid solar sector raised \$2.3 billion in external capital in debt, equity, and grants according to the GOGLA Investment Database (see Box 25). From 2016 to 2020, the industry saw yearly investment volumes plateauing between \$300 million and \$350 million, before reaching \$457 million in 2021, mainly driven by debt financing raised by industry's largest companies (Figure 62). Although not tracked in the investments database yet, 2022 is set to be another record year in terms of investment volumes.

Figure 62: Investment amount by investment type

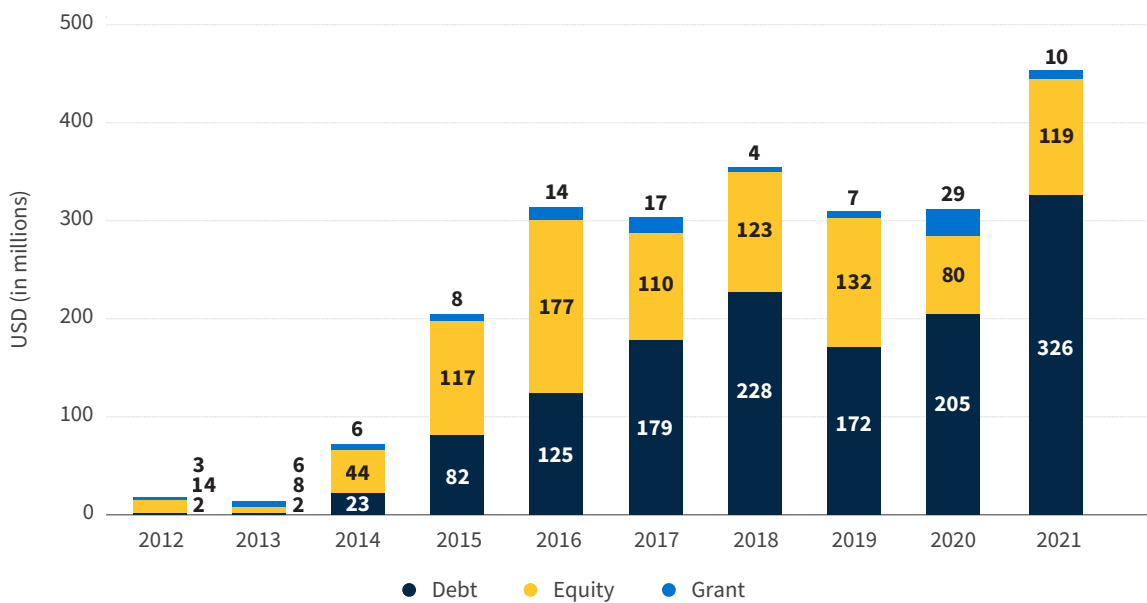

Box 25: GOGLA Investments Database

The GOGLA Investments Database was launched in 2017 to showcase investment trends in the off-grid solar industry. The database contains equity, debt and grant commitments reaching companies since 2012 and is updated every 12 months using information shared by industry respondents in interviews, and/or publicly announced deals in press releases, news reports and research reports.⁴⁵⁷

The GOGLA Investment Database includes data shared primarily by affiliate investors, companies and development partners.⁴⁵⁸ The affiliate market has good coverage of household solar, including cash sale and PAYGo market in Africa. South Asia and China are least represented.

OGS companies are bifurcating into two streams: players that are attracting the biggest share of the funding, described as scale-ups, and companies that are in their seed or start-up stages that have attracted significantly less capital. GOGLA Investments Database tracked 7 companies in the scale-up phase (attracting over \$100

million each), and over 150 companies that are in their seed or start-up phase (attracting up to \$100 million). 72% of current industry investment has been directed to the 7 scale-ups, with the remaining 26% directed to the other 150 companies in the database.⁴⁵⁹

⁴⁵⁷ Only direct commitment transactions to companies are tracked in the database and not funding towards industry funds.

⁴⁵⁸ For more information, please see: <https://www.gogla.org/access-to-finance/investment-data>

⁴⁵⁹ The remaining 2% could not be assigned to companies due to confidentiality.

7 companies in scale-up phase⁴⁶⁰

- Bboxx
- d.light
- Engie Energy Access⁴⁶¹
- Sun King
- Lumos
- M-KOPA
- ZOLA



The 7 companies in scale-up phase are solidifying their market position through their ability to attract capital, diversification of their investor base, and access to increasingly higher ticket sizes.

Figure 63: The 7 scale-ups - historical investments (equity, debt and grant)

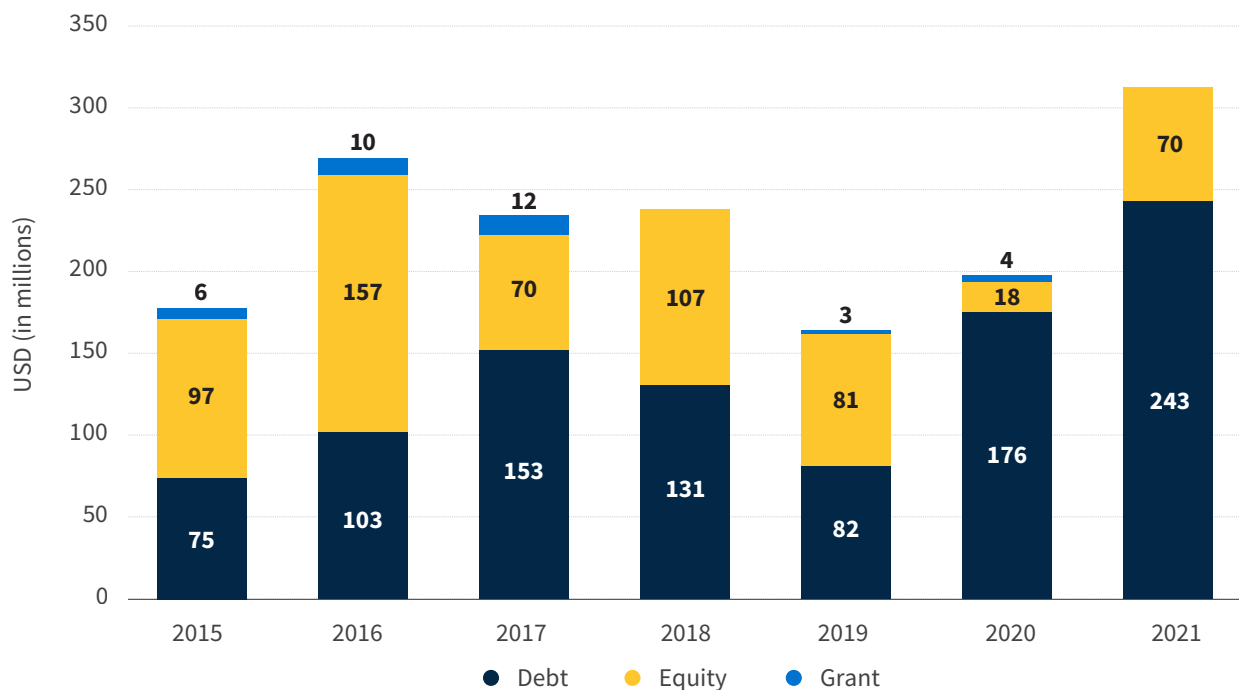

In the last two years, the 7 companies in their scale-up phase have expanded their consumer portfolio in established markets through large debt transactions (Figure 63). These companies have been able to access innovative debt financing structures, such as Special Purpose Vehicles (SPVs), which provide off-grid solar companies with flexible capital to finance continued growth and allow companies to focus on operations rather than financing. The most prominent case of this type of financing in the last two years was led by d.light, with over \$127 million raised via an off-balance sheet

financing vehicle in local currency that is dedicated to acquiring PAYGo accounts receivables from d.light's Kenya subsidiary.⁴⁶² In 2022, d.light announced a \$238 million expansion of this vehicle, with multi-currency financing over a two-year commitment period to expand to other African countries.⁴⁶³

Another important trend among the 7 scale-ups is the use of syndicated structures between commercial lenders and DFIs for local currency denominated deals. Syndicated deals among DFIs and banks act as a risk-mitigating mechanism to effectively de-risk commercial

⁴⁶⁰ The criteria to classify companies into start-up or scale-up is exclusively the total volume of investments attracted until 2021. Some of the companies in the 7 scale-ups might have different business models and paths to scale going forward.

⁴⁶¹ Includes investment volumes of its acquired companies historically.

⁴⁶² [Norfund \(2021\), Press Release BLK-1.](#)

⁴⁶³ The 2022 expansion is not included in the Investment Database yet.

capital for the sector. In 2021, Sun King announced one of the largest (\$75 million) syndicated sustainable finance deals in the region to be provided in local currency.⁴⁶⁴

Equity volumes for the 7 scale-ups did not grow comparably to debt in 2020 and 2021 (Figure 63), as COVID-19-induced uncertainty negatively affected company valuations and due diligence processes. Nevertheless, the 7 scale-ups seem to have overcome the pandemic and are reporting net profitability at the group levels⁴⁶⁵ (see Chapter 5). This is likely to unlock new, large equity raises which will help them expand into new markets and reach greater

numbers of consumers in the coming years. Consequently, established companies may grow faster, and more consolidation is likely to take place. The large equity raise by Sun King in 2022 reflects this trend (see Box 26).

The sector can also expect secondary equity exits or subsequent large equity raises from the 7 scale-ups.⁴⁶⁶

This will increase the confidence of other late-stage investors, proving the sector's equity returns multiples, and making capital available for the industry from early stage financiers. The recent exit by Apis Partners from Sun King is an example of this (see Box 26).⁴⁶⁷

Box 26: Sun King raises \$260 million in equity in 2022^{468,469}

Sun King (formerly Greenlight Planet) raised \$260 million in series D funding in 2022, marking a new record investment in the off-grid solar industry.

The funding round was an example of private venture capital and climate aligned financing entering the industry, led by a private equity and climate-aligned investor, BeyondNetZero, the climate investing venture of General Atlantic. As a result, former investor Apis Partners could partially exit its position.

Sun King plans to use the equity raise to expand its presence geographically and introduce larger products to its portfolio capable of powering appliances like refrigerators.



Investment volumes in start-up companies were negatively affected by the pandemic, slowing their growth.

COVID-19 negatively affected the volume of investments in start-up companies (Figure 64), slowing their growth.

In 2020, the volume of debt towards start-up companies decreased, substituted by larger volumes of equity and dominated by convertible debt deals, that translated into larger equity raises in 2021. In 2021, levels of debt bounced back, but have not yet reached pre-pandemic levels.⁴⁷⁰

The number of companies accessing equity in the last two years has remained relatively constant (Figure 65). Nevertheless, the pace of growth is behind the amount required to accomplish universal electrification. In 2018,

a Shell Foundation study estimated that to achieve SDG7 energy access goals, around 300 OGS companies raising significant equity and operating in both emerging and mature markets would be needed.⁴⁷¹ Start-up companies report that accessing equity capital has been challenging, resulting in some being over leveraged, and others facing business difficulties.

Lack of early stage equity has resulted in the stifled growth of many companies. This is a barrier to the expansion of off-grid solar in new markets; as equity, grants, or output based incentives, such as results based financing, are generally best placed instruments for market expansion (see Chapter 5 Market Landscape). However, the renewed confidence from investors in the 7 scale-ups could yield positive effects for start-up and growth-stage companies. Early stage capital could be released via secondary sales proving that the industry is viable and is poised for growth in multiple markets.

464 [Standard Bank Group \(2021\), Standard Bank Group, Citi, Norfund, \\$75 Million Sustainability Link Facility.](#)

465 [GOGLA consultations.](#)

466 [GOGLA consultations.](#)

467 [Apis Growth Fund \(2022\), Apis Growth Fund I partially Exits Position in Sun King.](#)

468 [TechCrunch \(2021\), Sun King Raises \\$260 Million to Widen Clean Energy Access in Africa, Asia.](#)

469 *This deal is not included in the Investment Database yet.*

470 *Note: A large share of relief funding recipients were unknown. Hence, they are not included in this graph. Relief funding totaled \$31 million in 2021.*

471 [Shell Foundation \(2018\), Achieving SDG7: The Need to Disrupt Off-grid Electricity In Africa.](#)

Figure 64: Investment trends in seed start-up and growth companies (equity, debt and grant)

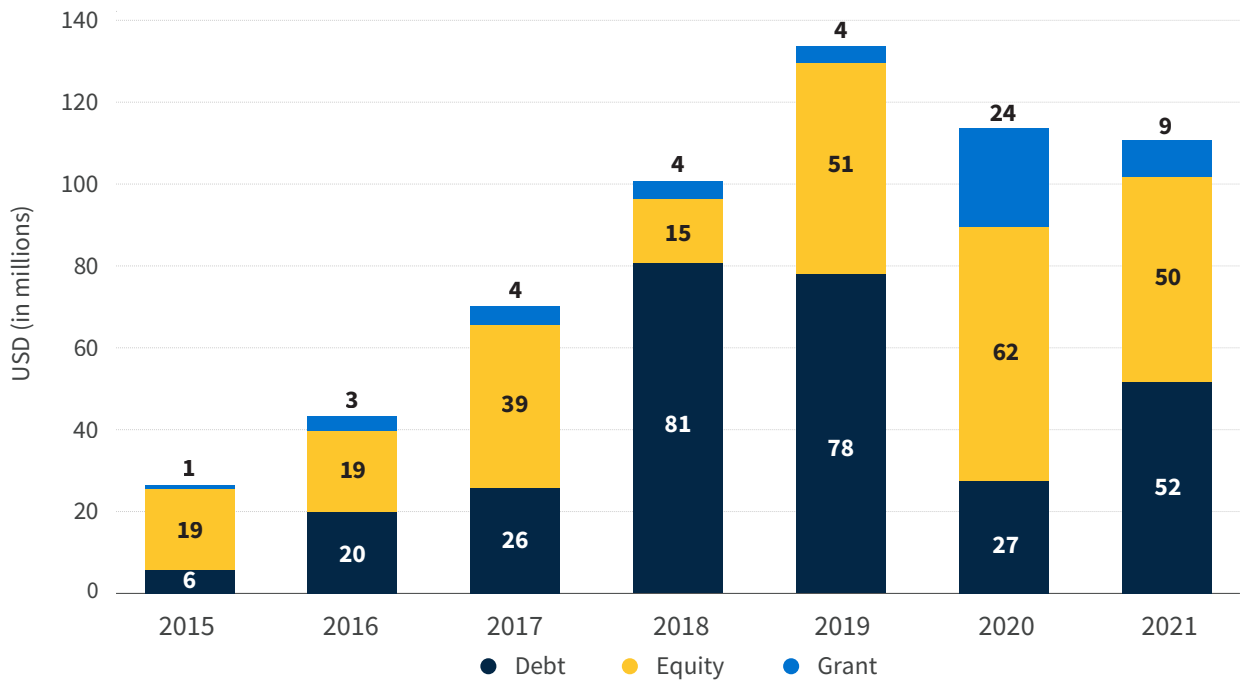
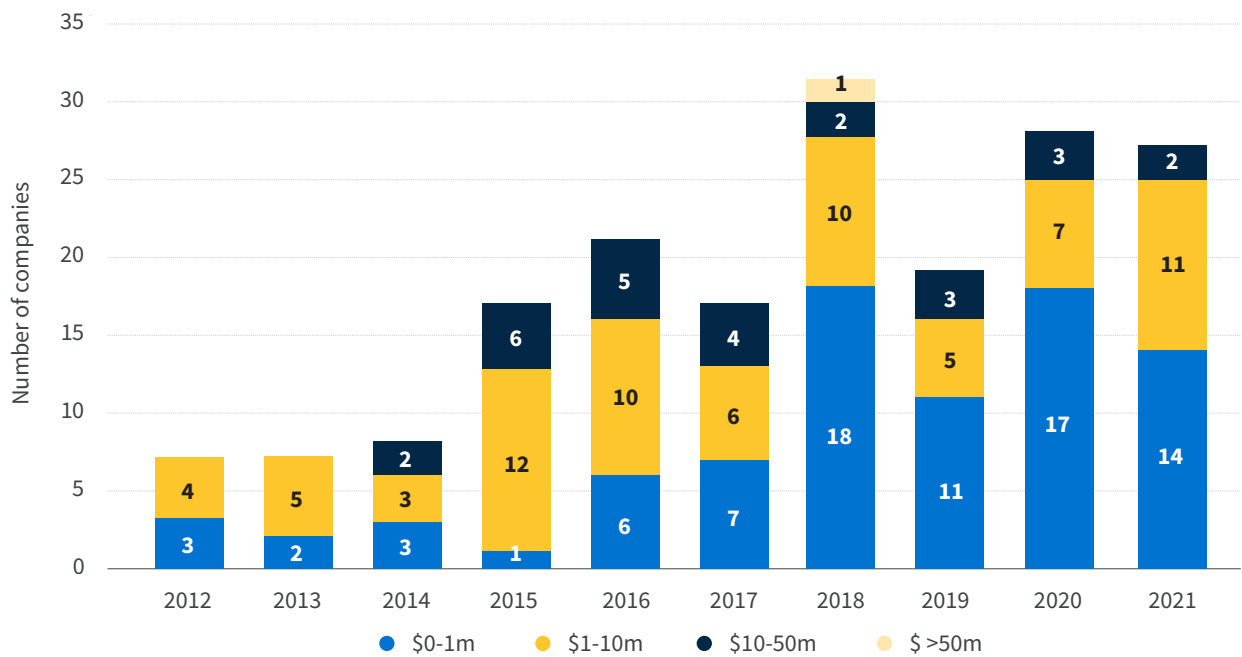

Figure 65: Number of companies receiving equity per year (per ticket size)



Only start-up and seed companies received grant capital in 2021, illustrating that grant makers are shifting their attention away from companies in their scale-up phase.⁴⁷² The recipients of grant financing were largely

local and productive use of energy (PUE) companies. Out of \$10.2 million grant capital provided in 2021, \$7.7 million was assigned to PUE and almost half of the capital was dedicated to locally-owned and managed companies.

472 Note: Grant capital excludes results based financing schemes.

Box 27: Locally-owned and managed companies

Locally-owned and managed companies are seeing more donor and investor interest. 50% of the total volume of grants and 10% of the total volume of equity tracked by GOGLA Investments Database was raised by local companies in 2021.

Some locally-owned companies have key roles as distribution partners. A Global Distributors Collective (GDC) study⁴⁷³ describes two types of distributors: Faster-growth last mile distributors (LMDs) that seek market leadership, rapid scale and/or international expansion and finance their growth via equity; and Slower-growth LMDs that pursue profitability before expansion and finance themselves mainly with grants and debt.

There are multiple donor and investor initiatives that have a specific focus on locally-owned companies. For example, a group of industry capital providers and development partners, the Household Solar Funders Group, designated access to finance for local companies as one of their three top priorities. Industry initiatives to enhance investor readiness of locally-owned and managed companies have also launched, such as GET.invest Finance Readiness support and GOGLA's ELEVATE; several industry investors have also included supporting local companies as priority in their investment thesis.^{474,475}

Box 28: Relief funding in the off-grid solar industry during COVID-19

Several initiatives have been launched to alleviate the effects of the pandemic, targeting seed and start-up companies.

In December 2020, The African Development Bank (AfDB) launched the COVID-19 Off-Grid Recovery Platform (CRP).⁴⁷⁶ The \$20 million concessional investment provided relief and recovery capital to energy access Acumen (2021), Coalition Launches Energy Access Relief Fund. businesses, anchored in a partnership with three specialized energy access fund managers: Triple Jump, Lion's Head Global Partners, and Social Investment Managers and Advisors (SIMA). The \$20 million concessional envelope was blended with the fund's own capital and instruments, leveraging \$30-\$40 million in complementary commercial funding, enabling more affordable debt products.

In September 2021, the Energy Access Relief Fund (EARF), a \$68 million fund, was launched with the aim of providing relief funding to start-up and growth-stage companies in the industry in the form of short-term, unsecured, highly concessional loans.⁴⁷⁷ The EARF targeted around 100 African and Asian energy access companies that are struggling with disruptions caused by the lingering effects of the pandemic.

Some country-level initiatives were also launched to provide relief initiatives, such as the AECF REACT Fund, that provided emergency grants of \$50,000 –\$200,000 to MSMEs in Kenya.



More consolidation is expected as a result of a maturing sector.

Investors in the sector believe consolidation in the industry is inevitable.⁴⁷⁸ Some commentators have expressed the belief that such consolidation is the natural evolution of a young sector and will be beneficial, allowing

companies to expand into new markets and grow their portfolio of customers. In time, this increase in scale may translate into increased operational efficiencies and economies of scale, which will drive down system costs and accelerate electricity access.

Industry insiders expect that the next wave of consolidation will not come from big energy conglomerates, but from market leaders acquiring smaller companies to expand their consumer base or geographical reach, or from growth-stage companies merging amongst themselves. Acquisitions in the sector among start-up and scale-up companies have taken place, sometimes as a result of companies facing business

473 [Global Distributors Collective \(2021\), *The Growth and Fundraising Journeys of Last Mile Distributors \(LMDs\)*.](#)

474 [GET.invest \(2021\), *GET.invest Launches Pilot of Finance Readiness Support to Unlock Financing for Clean Energy Companies*.](#)

475 [GOGLA \(2021\), *ELEVATE, Supporting the Next Generation of Off-grid Solar Companies*.](#)

476 [AfDB \(2020\), *African Development Bank Launches \\$50 Million Facility to Support Energy Access Companies*.](#)

477 [Acumen \(2021\), *Global Coalition Launched \\$80 Million Relief Fund to Protect Energy Access in Vulnerable Communities from COVID-19 Fallout*.](#)

478 [GOGLA consultations.](#)

difficulties or operating in mature markets with more aggressive competition. In 2022, the first big acquisition from one of the 7 scale-ups took place, with the acquisition of PEG Africa by Bboxx, proving that market leaders can use acquisitions for geographical expansion.^{479,480} Earlier acquisitions, such as Mobisol by Engie in 2019, have helped to allay investor fears that assets could be stranded by consolidation.

Productive use of energy (PUE) companies are in the early stages of the capital continuum, and attracted 9,8% of the total volume of capital in 2021 (\$44.9 million). Of this, \$21 million was directed to start-up or growth-stage companies. PUE companies can attract a wide pool of financiers due to the technologies' clear links to agriculture, infrastructure and climate adaptation and resilience. There is also strong

interest from grant-makers in supporting the expansion of this segment in the coming years. However, affordability of PUE products remains an issue for uptake and scale, and more incentives such as supply and demand-side subsidies are being explored (see Section 8.2.1).



Almost 10% of the total volume of investments in 2021 (\$44.9 million) was invested in PUE. Of this, \$21 million equity was directed to start-up or growth-stage companies.

Box 29: PUE focused companies capital raises in 2020 and 2021

SunCulture is leading the way in capital attraction for PUE. The solar water pump company has attracted around \$27 million debt and equity to date.⁴⁸¹ Its \$14 million Series A round in 2020 was led by Energy Access Ventures, and joined by Électricité de France (EDF), Acumen Capital Partners (ACP) and Dream Project Incubators (DPI). A subsequent \$11 million debt facility was led by SunFunder in 2021.⁴⁸² This was groundbreaking for the sector, due to its size and its combination of working capital and end-user financing. The company has also participated in Government subsidy schemes: in 2020, SunCulture was part of the CIZO cheque subsidy in Togo, where the Government provided a 50% subsidy to halve the cost of solar-powered farming and irrigation systems for 5000 farmers.⁴⁸³

Many other PUE companies are in the earlier stages of funding attracting equity; Bonergie Irrigation attracted \$2.4 million to scale-up access to solar-powered irrigation solutions in Senegal from Infraco Energy in 2021.⁴⁸⁴ Oorja, a solar-powered irrigation, milling and cooling company in India also raised a \$1 million seed funding round, with equity investment from Schneider Electric Energy Access Asia (SEEA).⁴⁸⁵ Another example is Simusolar, a distributor focussed on PUE which raised \$1.5 million from ElectriFi to strengthen operations in Tanzania and Uganda.

8.2. Additional Revenue Streams

A significant financing gap, coupled with the low purchasing power of off-grid solar customers, has popularized the development of additional income streams for off-grid solar companies that can help shore up revenues for business viability.

The most popular additional revenue streams for OGS companies are subsidies (results-based financing and end-user subsidies). Nevertheless, climate mitigation financing tools such as carbon financing and Renewable Energy Certificates (RECs) have started to emerge as alternatives and could be key to de-risking companies' portfolios, boosting investor confidence and effectively subsidizing consumers.

479 Previous acquisitions in the sector were made by large energy companies such as Engie.

480 [Bboxx \(2022\), Bboxx Consolidates its Market Leading Position by Acquiring Solar Energy Front-runner PEG Africa.](#)

481 [GOGLA Investments Database.](#)

482 [SunFunder \(2021\), Groundbreaking \\$11 Million Syndication for Sunculture to Expand Solar Irrigation.](#)

483 [ESI Africa \(2020\), Partnership Cultivated to Deliver Solar Powered Farming in Togo.](#)

484 [Power Engineering International \(2021\), Solar Powered Irrigation Systems Take Off in Senegal.](#)

485 [Oorja Solutions \(2021\), Oorja Raised \\$1 Million Seed Funding.](#)

8.2.1 Subsidies



The challenge of reaching the poorest customers has led to greater focus on funding via results-based financing and an emerging interest in end-user subsidy schemes.

Interest in using results-based finance (RBF) schemes to reach consumers and scale markets continued to grow. Of \$211 million that has been disbursed or is currently disbursing to the sector through RBFs since 2013, over \$100 million came on stream in 2020 alone (see Table 4). The results show that a relatively low level of investment can help to create significant impact. This is demonstrated in the case study on Nigeria (see Section 5.1). The success of RBFs is expected to lead to an expansion of this type of financing in the years ahead.

RBFs are being designed to meet a growing range of objectives. As well as broad market stimulation for quality-verified OGS products, RBFs are being used to meet a number of other goals. For example, the KOSAP Program is designed to reach specific marginalized customer groups (see Section 7.2) while Global Leap RBFs have been developed to drive uptake in emerging technologies.⁴⁸⁶ RBFs are also partnered with other public funding mechanisms so each mechanism can be targeted at the market barrier or objective it is most able to address. A common concern is that RBFs are more attractive to larger actors and that, as payments are only paid on results, smaller companies do not have the upfront finance to participate. RBFs such as the BRILHO scheme in Mozambique have therefore been teamed with catalytic grant finance to make it easier for smaller companies to take part in the initiative.⁴⁸⁷ As the sector develops, continued innovation is expected.

Results-based approaches are also being piloted to increase the use of OGS in public infrastructure. For example, a pilot in Tanzania is exploring the subsidization of community solar-powered clean water pumps. The cost of the village system is paid for through a grant (60%),

while a pay-for-water model is used to recoup the balance (40%) and to pay for ongoing maintenance. The initiative, implemented by the World Bank's Global Partnership for Results-Based Approaches and supported by SIDA and the Dutch Government, has been designed to mirror the current price that villagers are paying for water and uses mobile money technology to enable payments.⁴⁸⁸ This keeps costs stable for villagers but helps to partially fund the switch to a more sustainable water supply.

However, while RBFs can be particularly valuable in driving energy access, they have not been without challenges. For example, the verification process for RBF schemes can be complex and challenging to implement. This has led to delays in companies receiving financing in some cases, with knock-on impacts on financial planning.⁴⁸⁹ Concern around late payments has been cited as a deterrent by some smaller companies that have opted not to take part in current schemes, as they are not as well placed as larger companies to withstand a delay to expected cash flow. In 2021, EnDev, a leader in the design and implementation of RBFs in the OGS sector, launched a report to share lessons from its RBF programs in 14 countries.⁴⁹⁰ Amongst other insights, EnDev highlighted that having a deep understanding of market barriers to appropriately design an RBF and having a clear business proposition that will enable companies to understand how schemes can be integrated into their operational and financial planning, are key to their success. However, there is little data available on the different RBF designs and their long-term impacts. Greater analysis of the challenges, limitations and breadth of impacts created by RBFs is needed to continue to improve their design and implementation.



⁴⁸⁶ Global LEAP RBFs, implemented through the Efficiency for Access Coalition and managed by CLASP, aim to catalyze the uptake of high-quality, super-efficient appliances.

⁴⁸⁷ For more information, please see <https://brilhomoz.com/>

⁴⁸⁸ *The Global Partnership For Results-Based Approaches (2020), Closing Gaps and Financing Taps: The Next Step for Rural Water Supply.*

⁴⁸⁹ *GOGLA (2021), How End-user Subsidies Can Help Achieve Universal Energy Access.*

⁴⁹⁰ *EnDev (2021), Transforming energy access markets with Results-based Financing.*

Table 4: Results Based Financing funds⁴⁹¹

Fund Name	Amount committed	Donors	Implementing Agency	Target countries	Period	Products
Beyond the Grid Fund for Africa	\$36.2 million	Sida, BMZ, Danida	NEFCO & REEEP	Burkina Faso, Liberia, Zambia, Uganda	2021- 2026	SHS
EnDev/SNV Facilities	\$31.1 million	UK Aid, GIZ, SDC, USAID, BMZ, IKEA Foundation	EnDev, SNV, CLASP	Benin, Rwanda, Tanzania, Kenya, Bangladesh, Uganda, Mozambique	2013-2024	SHS, solar lanterns, multi-light systems, solar street lighting, solar water pumps, refrigerators, fans, TVs
Various government access projects supported through the World Bank	\$142.5 million	World Bank	Several	Madagascar, Kenya, Rwanda, Nigeria, DRC, Yemen, Haiti	2019-2027	SHS, solar lanterns, multi-light systems
USAID Funds	\$1.7 million	USAID	Power Africa, Powering Agriculture	Malawi, Kenya, Tanzania, Uganda, Zambia	2019-2021	SHS, solar water pumps, refrigerators, fans, TVs, electric pressure cookers

A better understanding of the growing affordability gap has also led to increasing interest in end-user subsidies (EUS). An EUS directly reduces the cost of a product for a consumer and is designed to specifically help those on very low incomes access off-grid products. EUS may be applied to the off-grid product price directly by the company, which then receives a grant to make up the difference, or customers may get a voucher or direct cash transfer to help them buy a product. Amongst others, the Pro-Poor RBF pilot program in Rwanda supported by EnDev, and the Togo CIZO program, supported by the AfDB and EU, have proven successful in reaching low income households. This success has been translated into nationwide scale up of the pilots.⁴⁹² The ESMAP/Lighting Global program is also supporting the development of end-user subsidy programs in several other countries, as part of larger World Bank lending programs, including in DRC, Niger and Nigeria.

A number of EUS schemes for solar irrigation are also being implemented and explored. For example, the KUSUM scheme in India is a frontrunner (see Box 9), while the second phase of the CIZO scheme in Togo has been expanded to incorporate solar water pumps. The AfDB also provided a grant to the government of South Sudan to help

install 1170 solar pumps, covering 75% of the cost.⁴⁹³ The grant is additionally being used to establish workshops to maintain the pumps and a pump testing laboratory to provide certification and training. These schemes are designed to enhance agricultural communities, increase food security and reduce CO2 emissions by replacing diesel water pumps. The comparatively high cost of solar water pumps, as well as other PUE solutions, suggest that EUS and other innovative schemes will be needed to drive scale and access to these technologies.

The introduction of EUS into the market is likely to have a significant impact on investment in the off-grid sector, through an uptick in public finance and a knock-on impact on commercial finance. This is particularly the case where very specific targeting of poor households is not easily feasible, and where EUS are being applied to all products and services. However, while the risk that EUS could make some markets less commercial remains, they also have the potential to open up fragile, conflict and violence (FCV) affected markets and reach new and more vulnerable customer segments, creating more opportunities for investment in the long term. EUS may also be needed to unlock markets and

⁴⁹¹ This overview includes RBFs that have disbursed funds, are currently disbursing, or will start disbursing before 2023. The full amounts are disbursed to companies and do not include programmatic costs.

⁴⁹² The scale up of the Pro-Poor RBF in Rwanda is funded by the World Bank.

⁴⁹³ AfDB (2019), Sudan: African Development Bank Approves \$21.783 Million Grant for Roll Out of Solar-Powered Irrigation.

investment opportunities for larger, more expensive, PUE technologies, where affordability for lower income customers is already a well documented barrier.

8.2.2 Climate Mitigation Financing



Several market barriers have prevented the realization of the full potential that carbon markets offer for off-grid solar. However, the industry is starting to see positive developments.

Some companies are beginning to tap into the voluntary carbon markets to monetise their greenhouse gas (GHG) emission reductions. Yet, this opportunity is currently limited by several market barriers. These include the complexity of regulatory compliance with carbon markets, the high transaction costs for companies, and the fact that, using current methodologies, off-grid solar projects yield relatively small amounts of emission reductions when compared to utility-scale renewables, meaning that the cost to generate carbon offset could exceed the economic

benefit. Nevertheless, some companies are benefiting from this financial mechanism. For example, Namene Solar, an off-grid solar distributor, has achieved Gold Standard certification for projects in Zambia and Namibia.⁴⁹⁴

Carbon Financing also creates an opportunity for new service providers. One such organization, Solstroem, is already simplifying the process for off-grid solar companies to access carbon financing by aggregating and generating micro-credits for companies directly, avoiding the high transaction costs implied for smaller companies.

The D-REC Initiative provides another example of how off-grid solar companies could benefit from climate financing. Distributed Renewable Energy Certificates (D-RECs), are certificates representing one kilowatt-hour (kWh) of electricity that has been generated from a distributed renewable energy source (or multiple sources). These certificates allow renewable energy project developers to certify every kWh of electricity their projects generate. The initiative will use open source technology to measure and verify the electricity produced from the underlying projects, then issue and certify D-RECs to capture the positive environmental attributes associated with that generation. Renewable energy providers will then monetize these D-RECs by selling them to corporations that can then use them in their sustainability reporting. However, this initiative is currently pre-pilot and it is yet undefined how off-grid solar companies may benefit from it.

Box 30: Climate-aligned financing in off-grid solar

Climate-aligned financiers have started to realize the potential of off-grid solar for climate mitigation, adaptation and resilience; and are gradually becoming involved in the sector. The Green Climate Fund, the largest global fund dedicated to help fight climate change, is supporting several initiatives in the off-grid solar sector, including the Energy Access Relief Fund, KawiSafi Ventures, and most recently the \$171 million contribution to the AFDB's Leveraging Energy Access Finance Framework (LEAF) program. In 2021, Sun King received the first Green Bond of the industry, issued by Symbiotics.⁴⁹⁵

The promise of an increase in adaptation finance at COP26 is an opportunity for the off-grid solar industry. In 2019/20 less than 10% of climate financing went to adaptation, with the majority of funds going to large infrastructure projects in developed and middle-income economies.⁴⁹⁶ COP26 pledged \$100 billion per year in climate finance by 2023, and a promise from the investment community of greater equity for developing countries and parity for adaptation funding.

Access to electricity from OGS products can help people adapt and become more resilient in a variety of ways, including income diversification and access to digital services. Beyond this, appliances such as solar water pumps help smallholder farmers increase crop yields and profitability while adapting to unpredictable rainfall patterns; cold chain technologies strengthen agricultural value chains, enhance food security and support health interventions; and access to radios and mobile phones helps disseminate climate information and early warning systems.

⁴⁹⁴ [Namene Solar \(2021\), Climate Projects Namene Solar.](#)

⁴⁹⁵ [Symbiotics Group \(2021\), Symbiotics Launches \\$15 Million Green Bond.](#)

⁴⁹⁶ [Climate Policy Initiative \(2021\), Global Landscape of Climate Financing.](#)

A framework for how OGS is supporting adaptation and resilience is currently absent, but could lead to improved performance and unlock pathways to climate financing. Unlike avoided CO2 emissions, metrics for adaptation need to allow for context-specific outcomes. A measurement framework should be flexible, realistic for company implementation, local, focused on end-users, and go beyond financial and output-based measurements. Existing frameworks such as the Race to Resilience metrics, International Climate Finance KPIs and BFA's Digital Finance for Climate Resilience can be used as a basis from which to develop sector-specific metrics that meet the criteria outlined above.

New climate focussed challenge and grant funds relevant for the sector are also emerging. These include the recently launched GSMA Innovation Fund for Climate Adaptation and Resilience, the Dutch Fund for Climate and Development, EEP Africa and Africa Adaptation Acceleration Program. Such funds serve as entry points for the OGS sector to access climate funding and support industry efforts to develop a framework and demonstrate impact.

8.3 Sources of Capital

8.3.1 Capital Provider Trends



Specialized industry funds will be key to crowding-in and de-risking institutional and climate investors in the OGS sector.

Specialized industry funds have already played a key role in the financing of off-grid solar and PUE companies.

As they act as aggregators for investors with different risk and impact profiles, they represent an easier point of entry for investors unfamiliar with the sector, more risk averse, or unable to make direct investments in the industry. The potential success of specialized industry funds in diversifying their investor base and attracting climate-first and institutional investors could be a game changer for the industry's financing landscape. The size of specialized funds could significantly increase if bilateral donors, DFIs, foundations and other junior lenders create a base for greater numbers of senior lenders to step in via first-loss layers of capital and guarantees (see Box 31). The role of industry's specialized funds is also relevant to reach companies with smaller ticket sizes. The Energy Access Relief Fund, SIMA-Angaza Distributor Fund and Acumen Fund are good examples of this.

Box 31: \$500 million Gigaton Empowerment Fund by SunFunder

One of the industry's main fund managers, SunFunder, is raising funds for the \$500 million Gigaton Empowerment Fund, which aims to improve energy access for over 10 million people and reduce more than 18 million tons of CO2e.

The Gigaton fund is focussed on attracting institutional investors as senior lenders, and has recently been shortlisted by the UN-convened Net-Zero Asset Owner Alliance, a group of 60 institutional investors with \$7 trillion Assets Under Management. Such a step from institutional investors would be significant for the financing landscape of the sector.



Foundations have continued playing a catalytic role, mainly acting as anchor investors of sector specialized funds.

Foundations are key players in the energy access space as drivers for *additionality*⁴⁹⁷, acting as risk mitigators to crowd-in other investors, both in their role as investors

through first loss or concessionary capital tranches in industry's specialized funds, and through their role as grant makers. There are many industry specialized funds where foundations and philanthropies have acted as first-loss investors. A recent example is the Energy Access Relief Fund; where Shell Foundation, Ikea Foundation and the Rockefeller Foundation, alongside ESMAP and the IFC, participated providing first loss layers or highly concessionary funding, which helped the fund to launch and catalyze engagement by other investors with lower tolerance to risk.

Some foundations in the industry provided direct grant financing to companies. A recent example is the

⁴⁹⁷ *Additionality in this case pertains to providing financing where other funders are not willing to venture while prioritizing the follow-on of other investments.*

partnership between Shell Foundation (SF) and U.S. International Development Finance Corporation (DFC) where Shell Foundation has committed to deploy \$45 million grant funding by 2025 to build a pipeline of start-up and venture stages Distributed Renewable Energy (DRE) companies.⁴⁹⁸ The role of DFC is to provide early-stage debt and equity to support growth of these businesses for further scale.



Development finance institution (DFI) investments and bilateral donors continue to be critical for the sector, through both direct investments, syndications and investments made through funds.

DFIs, bilateral and multilateral donors have maintained their commitment and exposure to the sector through multiple investment channels and via the creation of new funds.⁴⁹⁹ An example is the Energy Entrepreneurs Growth Fund (EEGF), which began disbursing equity or capital to venture-stage companies in 2021. The EEEFG was created by Shell Foundation, co-funded by UK aid, and the Dutch Entrepreneurial Development Bank (FMO) and is managed by Triple Jump.⁵⁰⁰ The fund completed its first investments in 2021 to Yellow and Baobab+. Other examples include the Africa Go Green Fund backed by KfW and SunFunder's SET fund backed by DFC.

DFIs have also continued lending directly to companies.

This is mainly through debt, but also through equity investments such as the \$10 million investment made from Norfund to Baobab+ in 2021, the \$10 million raised by d.light from PROPARCO, and Simusolar's \$1.5 million convertible debt raise from ElectriFi.^{501,502,503}

Some DFIs have invested in expanding securitization structures for the industry. These include Norfund's investment in the expansion of d.light's BLK 1 vehicle in

Kenya by Africa Frontier Capital. The expansion saw Norfund join DFC as a senior lender in the BLK1 structure, which is a local currency impact financing vehicle dedicated to providing d.light's Kenyan PAYGo SHS business with access to on-going, flexible and sustainable receivables funding.

Another role that DFIs and bilaterals have undertaken has been to provide risk guarantees, which are vital for leveraging more sector investments. Guarantees provided to the sector take different forms: MIGA provided guarantees to sector funds that invested in Bboxx to address political and currency convertibility risks, while SIDA provided guarantees to help launch and catalyze investments in industry funds such as the SET Fund by Sunfunder.^{504,505} The European Commission also approved a guarantee for TCX to reduce the costs of hedging in 2021.⁵⁰⁶



Crowdfunding platforms are established as a stable source of investment for off-grid solar companies at all stages, as an easy to deploy instrument.

Investments through crowdfunding platforms have remained stable. Their popularity as a quick mechanism to provide flexible financing has been recognized by sector donors and DFIs which are getting involved in the creation of new structures to resolve market gaps, such as the lack of local currency financing. For example, in 2021, the first local currency denominated deal via a crowdfunding platform was realized via a partnership between TCX and Lendahand.⁵⁰⁷ Another example is the €49 million financing agreement provided by KfW to the Clean Energy and Energy Inclusion for Africa Foundation (CEI Africa). This will provide co-financing and technical assistance to crowd lenders to provide financing for solar lighting, solar home systems, solar-powered mills, solar water pumps, and cooling systems.⁵⁰⁸

498 [ESI Africa \(2021\), Shell Foundation and DFC Collaborating To Accelerate Energy Access.](#)

499 [The GOGIA Investments Database tracks lead investors. In 2021, DFIs supported several commercial deals but not with majority stakes.](#)

500 [Shell Foundation \(2021\), Energy Entrepreneurs Growth Fund Announces three new Investments in African Energy Access.](#)

501 [Norfund \(2021\), New Investment Aims to Equip One Million Households with Solar and Digital Products.](#)

502 [Proparco \(2021\), Proparco Supports d.light: A Global Leader in Solar Energy.](#)

503 [ElectriFI \(2021\), Simusolar Secures \\$1,5 Million Convertible Note from EDFI.](#)

504 [Africa Energy Portal \(2021\), MIGA Guarantees Bboxx Solar Systems in Rural Areas.](#)

505 [SunFunder \(2021\), SunFunder Completes SET Fund.](#)

506 [European Commission \(2021\), A Range of Financial Guarantees to Boost Investment in Africa and the EU Neighbourhood.](#)

507 [Lendahand \(2021\), Financing SMEs in their Local Currency.](#)

508 [Triple Jump \(2021\), Triple Jump B.V., Persistent, and GreenMax Capital Advisors Awarded Management of the Newly Launched Clean Energy and Energy Inclusion for Africa Foundation.](#)



Commercial debt and equity investors have made opportunistic investments in the sector, signaling a further step in the maturity of the industry’s big players.

To date, most commercial debt lending has been supported by DFIs. While the need for support from DFIs and impact investors is likely to continue in the near future, commercial capital is expected to gain importance as a funding source. An example is the \$75 million syndicated debt facility raised by Sun King in 2021, which was led by Standard Bank Group and Citi, together with CDC and Norfund.⁵⁰⁹

Commercial equity investors and strategic corporates have made opportunistic investments, and are active partners in driving value. Commercial equity funds are seeing an opportunity to diversify their portfolio with PUE companies, and off-grid solar service providers. The \$260 million equity raise by Sun King was led by a climate aligned growth-equity investor, BeyondNetZero, the climate investing venture of General Atlantic, with participation from M&G Investments’ Catalyst and Arch Emerging Markets Partners.⁵¹⁰ Strategic corporations have also kept their interest in off-grid solar and productive use

of energy. For instance, EDF took a 23% stake in Bboxx Kenya and Canadian Solar invested early stage equity in Solarworx.^{511,512}

8.3.2 Investor Confidence



Investors expect the pandemic to be a short-term financial setback, and remain positive in their financial expectations for 2022.

COVID-19 negatively affected the financial performance of companies compared to investor expectations in 2021. In mid 2020, the early days of the pandemic, only 13% of investors stated that their off-grid solar portfolio was underperforming compared to their financial expectations. When asked the same question in 2021, the result was 28%. Investors expect this trend to be short-term, and remain bullish in their financial expectations for 2022, claiming that performance of their off-grid solar portfolio assets will realign with their expectations in the year. Only 5% advised that they expect their portfolio to underperform (Figure 66).

Figure 66: Investor survey 2020 & 2021: How is your off-grid solar portfolio performing relative to your financial expectations?

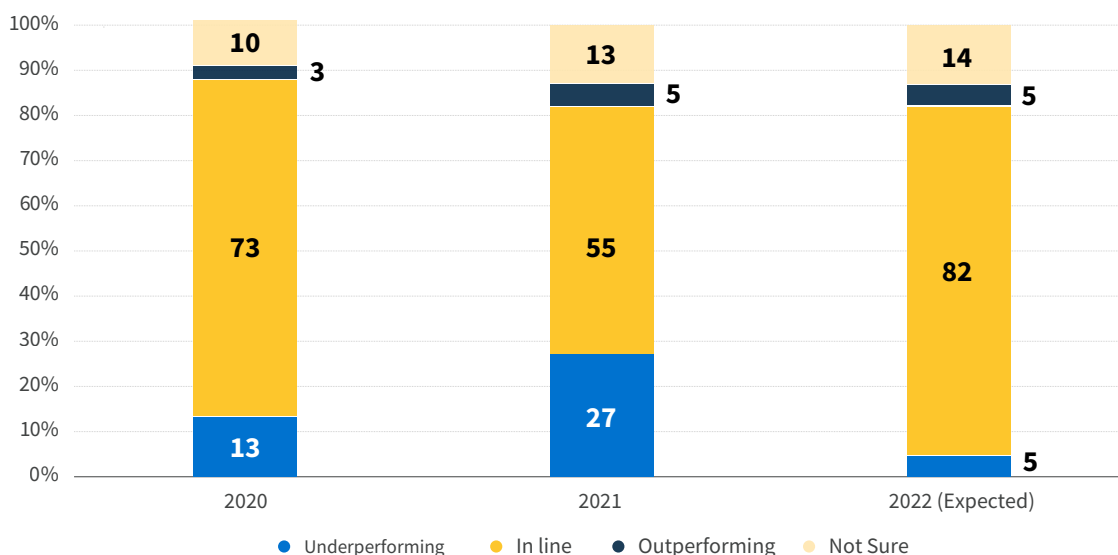

509 [British International Investment \(2021\), Greenlight Planet Secures \\$75 Million Debt Facility.](#)

510 [TechCrunch \(2021\), Sun King Raises \\$260 Million to Widen Clean Energy Access in Africa, Asia.](#)

511 [Bboxx \(2021\), Bboxx and EDF Ramp up Partnership with Investment in Kenya Expansion.](#)

512 [Solarworx \(2021\), Canadian Solar Invests in German Off-grid solar Pioneer Solarworx.](#)

Despite the financial challenges, investors with current exposure in the industry remain committed to the sector: 86% of investors surveyed in 2021 expect to either increase or maintain their exposure in the industry in 2022 (Figure 67). This is a result of their long-term strategic interest in the industry, an understanding of the difficult

market conditions and the more positive picture seen around performance in the industry as a whole. Investors remain optimistic about the sector's impact and 90% of investors cite this as a key reason they plan to maintain or increase their investment exposure going forward.

Figure 67: Investor survey 2021: Relative to past years, how do you expect your off-grid solar activity to change in 2022 (in terms of total amount invested)?

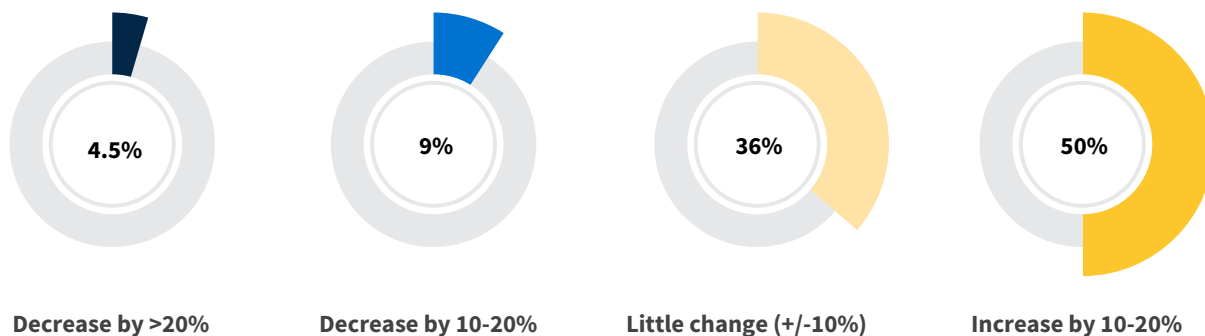

8.4 Regional Trends



Almost 50% of historical funding flows have been invested in operations in East Africa. However, investors have been increasingly focused on West Africa in the last two years.

The largest share of funding to date has been assigned to East Africa (49%).⁵¹³ This is predominantly linked to large debt deals assigned to the 7 scale-ups companies to finance their working capital requirements in their most established markets. In 2021, for instance, of a total \$328 million, \$189 million debt commitments was assigned to East Africa, compared to \$25 million assigned to West Africa (Figure 68).

Large amounts of investments, such as the equity raises from the 7 scale-ups companies operating globally, cannot be allocated to regions.⁵¹⁴ New equity raised by the big players for expansion in new markets such as Sun King and M-KOPA suggest that this trend could soon change

and that market expansion towards new geographies will be effective once the large players start raising capital to expand their consumer base in specific regions.^{515,516}

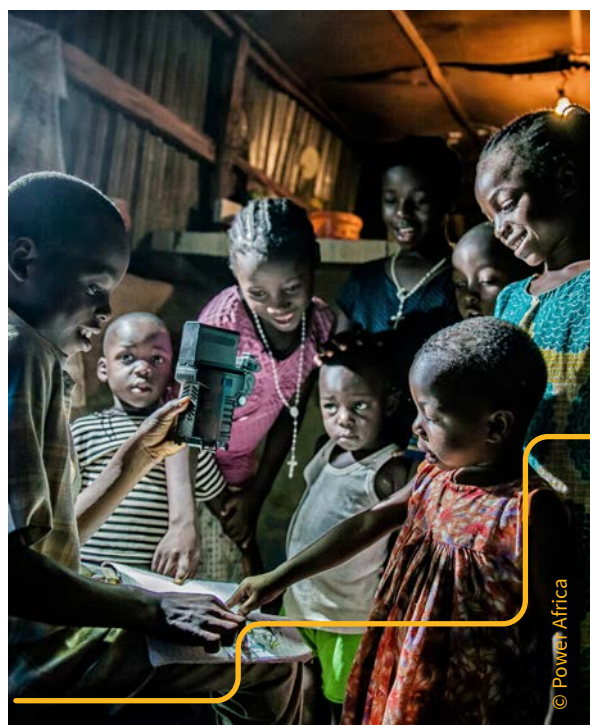

© Power Africa

⁵¹³ A large share of deals in the GOGLA Investments Database cannot be assigned regionally due to companies doing capital raises for their global operations.

⁵¹⁴ This is primarily the case with equity deals assigned to vertically integrated companies. However, some of the debt deals are global by nature as well.

⁵¹⁵ [TechCrunch \(2021\), Sun King Raises \\$260 Million to Widen Clean Energy Access in Africa, Asia.](#)

⁵¹⁶ [TechCrunch \(2022\), M-KOPA Raises \\$75 million as it Clocks 2 Million Customers Across four African Markets.](#)

Figure 68: Investment amount by geographical focus of funds

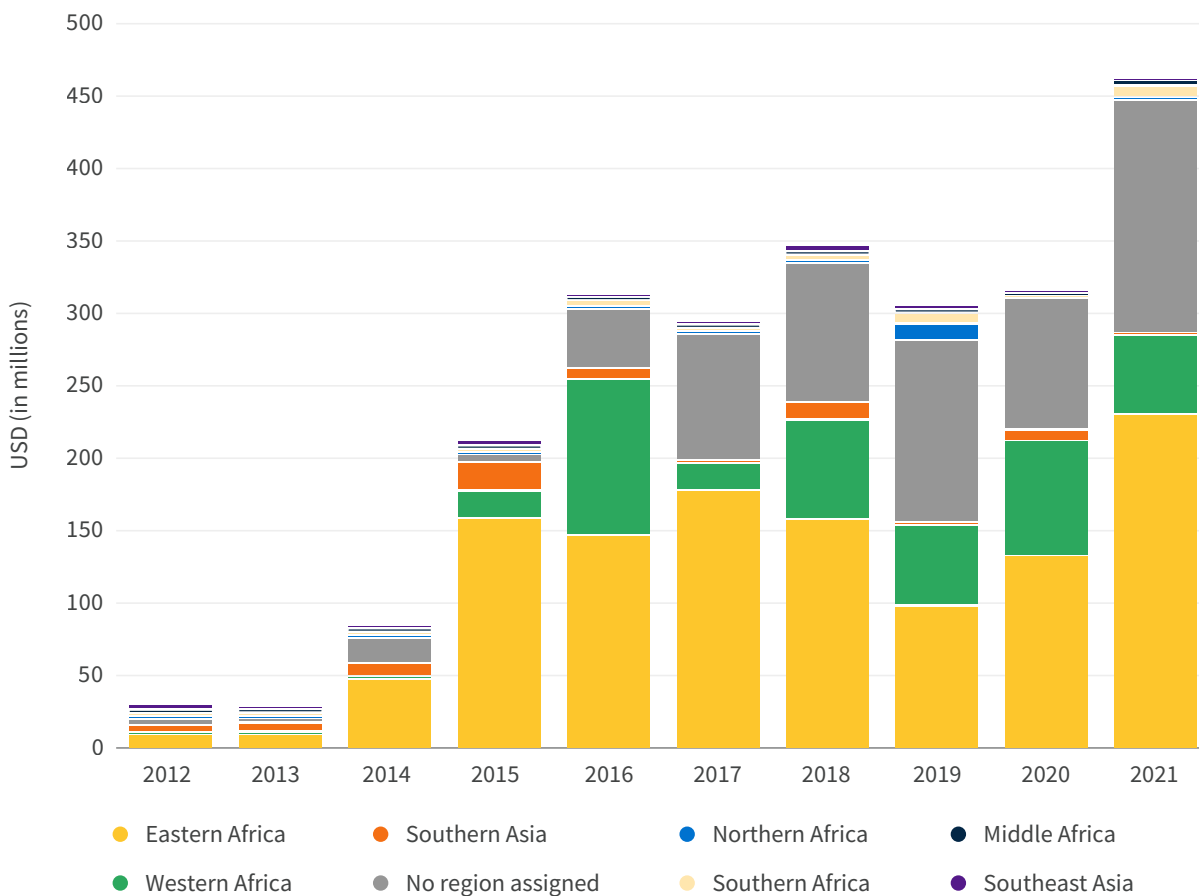

Analyzing the overall number of transactions, more companies are receiving investments in the West African market in the last two years. For instance, this is notable in equity deals in 2021 where the amount of companies receiving an equity investment was higher in West Africa than in East Africa, reflecting that there are early-stage companies poised for growth in the region.⁵¹⁷ Nevertheless, the total value of investments does not yet match those in East Africa, as the companies receiving investments in West Africa are generally in earlier stages of growth and are not yet able to absorb large ticket sizes.

There is limited data available on investments in the off-grid solar industry in Asia, in part due to the fact the market is dominated by non-affiliate companies not part of the Investment Database. Furthermore, the limited penetration of the PAYGo business model and other less capital intensive models, such as direct cash sales or partnerships with microfinance institutions, contribute to the lower investment in the region. New opportunities are arising with the uptake of PUE products in Asian markets such as India, where early stage equity deals have been announced and growth is expected.



⁵¹⁷ GOGLA Investments Database.







Annexes





Annex 1 - Definitions of Key Household Product Segments

Product Category	Definition	Power Range (Wp)	Indicative Price Range (\$) ⁵¹⁸	MTF Level	Example
Portable lanterns	Single light only	0-1.49	\$4 - 40	Enables Tier 0 (or partial Tier 1) Electricity Access for an individual person	 d.light S3
	Single light & mobile charging	1.5-2.99	\$6 - 51		
Multi-light systems	Multiple light & mobile charging	3-10.99	\$37 - 208	Enables Tier 1 Electricity Access for at least one person and up to a full household	 Barefoot Power Li1000
Entry-level SHS	Three to four lights, phone charging and powering a radio	11-20.99	\$33 - 333	Enables Tier 1 Electricity Access for a household	 Bboxx Flex 40
Basic-capacity SHS	As above, plus power for a television, more lights, appliances & extended capacity	21-49.99	\$40 - 686	Enables Tier 2 Electricity Access for a household when coupled with high-efficiency appliance	 StarTimes Solar S100
Medium-capacity SHS	As above, but with extended capacities	50-99.99	\$50 - 1100	Enables Tier 2 Electricity Access for a household even using conventional appliances	 BioLite SolarHome 620
Higher-capacity SHS	As above, but with extended capacities	100+	\$248 - 2862	Enables Tier 2 Electricity Access for a household, even using conventional appliances	 JUA H4G-300

⁵¹⁸ See Annex 5 for discussion on methodology for determining product pricing trends for the global OGS market.

Annex 2 - Definitions of Key Household and Productive Use Appliance Segments

Household / small business appliances			
Product Category	Application	Indicative Price Range (\$)	Example
Televisions	Television sets provide access to entertainment, educational content, and news. Most televisions sold as part of SHS kits are DC-powered, although AC-powered sets can be used with DC-AC solar inverters.	\$34 - 325	 <p>NIWA Solar ELED TV 23.6"</p>
Fans	Fans improve household comfort, especially during hot seasons.	\$14 - 65	 <p>fosera. POWER LINE Standing Fan 12V</p>
Refrigeration units (up to 300L capacity)	Off-grid refrigeration units reduce the risk of food contamination and preserve perishable produce and beverages for both households and small shops in rural, remote communities.	\$72 - 1817	 <p>Koolboks Refrigerator</p>
Other	Other, smaller appliances include radios for households and multi-port phone chargers for small businesses.	Variable	 <p>Sun King Radio</p>

Productive use appliances			
Product Category	Application	Indicative Price Range (\$)	Example
Solar water pumps (up to 2kW)	Solar water pumps improve irrigation and extend the growing season for rural smallholder farmers.	\$107 - 7630 ⁵¹⁹	 <p>Futurepump SF2 Solar Pump</p>
Refrigeration units (up to 300L capacity)	Off-grid refrigeration units reduce the risk of food contamination and preserve perishable produce and beverages for both households and small shops in rural, remote communities.	\$72 - 1817	 <p>Koolboks Refrigerator</p>
Cold-storage solutions (> 300L capacity)	Solar-powered cold-storage solutions enable larger scale preservation of produce, meat, and dairy products, targeted mostly at small businesses.	\$3,456 - 150K+ ⁵²⁰	 <p>Ecozen EcoFrost</p>
Agro-processing equipment	The most common agro-processing application is solar-powered grain milling, given the importance of the maize value chain in sub-Saharan African markets.	\$660 - 1,310	 <p>AGSOL Solar Powered Mill</p>

⁵¹⁹ Prices for solar water pumps include systems up to 5kW in size. In certain markets, such as India, much larger, more expensive solar-powered systems are used.

⁵²⁰ Refrigeration for productive use ranges from small, household-sized refrigerators to large, walk-in refrigerators that sell for \$100,000 or more.

Annex 3 - Company Typology

Off-grid solar companies can be classified in different ways. For the purpose of this report, companies are categorized according to the company types below. Please note that the figures are for illustrative purposes only and this list of companies is by no means exhaustive.

- **Manufacturers:** Manufacture products across solar energy kits offering
- **Vertically integrated:** Operate across the entire value chain (manufacturing, distribution, and service provision)
- **Distributors**
 - **Specialized OGS distributors:** Have PAYGo offering, primarily distribute OGS
 - **Last mile distributors:** Have OGS as part of their portfolio but also distribute other products/ services
 - **(Third party) E-commerce platforms:** Provide OGS products via a third party or their own online platform
 - **Traditional retailers:** Provide OGS products via a physical location
- **Service providers:** Provide a service solution (e.g. digital payments) to OGS companies

Figure 69: Companies selling solar energy kits and services

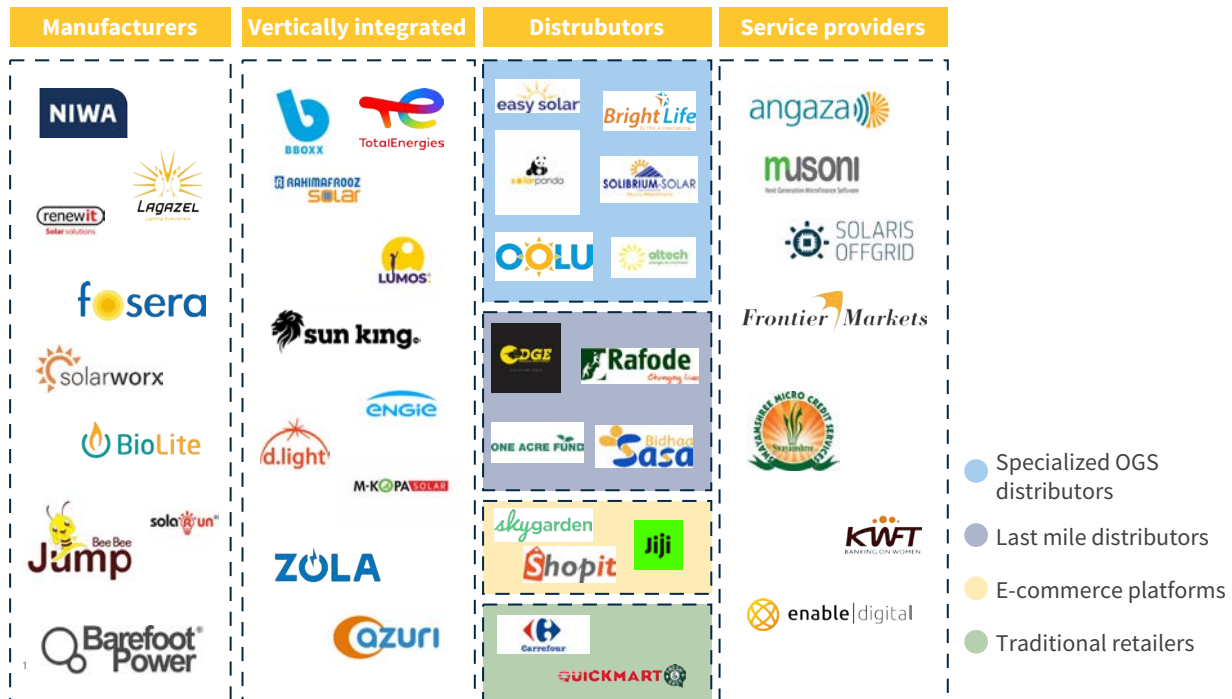
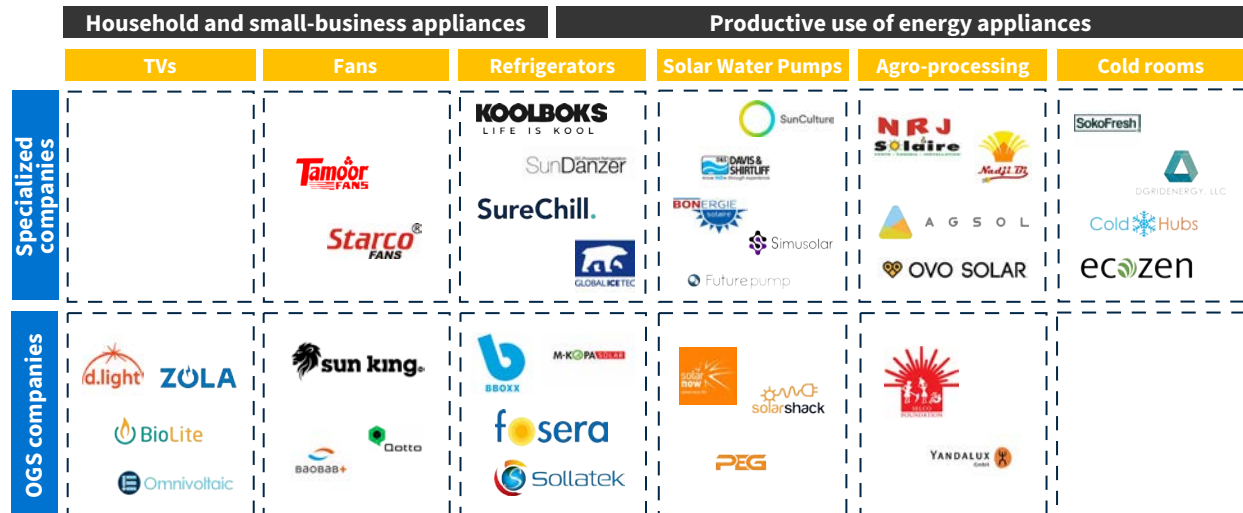

Figure 70: Companies selling off-grid solar appliances



Annex 4 - Affordability Methodology

To estimate affordability of off-grid solar products, an estimate for (1) ability to pay (demand) is compared to latest data on (2) supply (pricing). This box explains the approach taken to constructing demand curves, and comparing the demand curves to the cost of acquiring OGS products on a cash over-the-counter basis and/or using some form of end-user finance, such as the PAYGo business model.

Step 1 - Estimating ability to pay

Ability to pay is analyzed bottom-up from proxy demand by country. First, a country-by-country demand curve is built up from:

1. The distribution of consumption expenditure for each country from the latest available year of data in PovcalNet, which gives us the shape of a demand curve for each country.
2. An estimate of the total income across each national population, using GNI per capita (GNI, Atlas method, current \$).
3. Aggregating per capita demand into household demand, using household size per country from the Population Research Bureau
4. Estimating a minimum and a maximum affordable expenditure as:
 - a. for small lighting products assuming these will be paid in full upfront (cash over-the-counter), allocating between 5% and 10% of monthly household income, saved up for three months,
 - b. for multi-light systems and solar home systems, assuming these may be purchased with end-user financing, with an allocation of between 5% and 10% of monthly income to repayments each month.

In practice, many households do commit 10% or more of monthly expenditure to energy access - and sometimes even up to 25%. However, spending over 5% is typically considered the threshold for energy poverty, as spending

more than this will quickly mean sacrificing expenditure on other primary goods and services. For a longer discussion of the use of the 5% and 10% monthly thresholds, refer to the Off-Grid Solar Market Trends Report 2020.

Finally, we present two possible affordability analyses for OGS products. The first is conservative and may better represent the remaining unconnected households, and one that is much more optimistic but represents ability to pay including in urban areas potentially as a back up to the main grid

- Conservative - bottom up: for this analysis, the demand curve for each country is built from the bottom end of the income distribution, up to the total size of the remaining energy access gap. For example, for a country with 100 million people, of which 20 million still lack access to energy, the demand curve is based on the estimated income of the poorest 20 million people only. This is probably a reasonable proxy for the ability to pay to close the energy access gap, as those without access to energy are likely to be among the poorest in their country
- Maximum - nationwide income distribution: here the national income distribution is used, which may be a more representative estimate of ability to pay including potential OGS customers who are stepping up the energy staircase (i.e. already have access to an OGS product) and/or may be using their OGS product alongside a weak grid connection

Step 2 - Comparing the cost of acquiring an OGS product

These demand curves are then compared to the cost to purchase an off-grid solar system. The prices used are shown below (Table 5), with the PAYGo prices then calculated based on a 10% upfront deposit and 12 to 18 monthly repayments based on an annualized cost of consumer finance of 40%, which results in a PAYGo price premium of around 26%.

Table 5: Indicative prices of off-grid solar products (\$)

Product	Capacity	Median price 2020 (\$)	Median price 2022 (\$)	Min price 2022 (\$)	Max price 2022 (\$)	Business model
Single Light	(Less than 1.5 Wp)	8.37	9.08 (+8%)	3.71	39.91	Cash over-the-counter
Single Light & Mobile Charger	(1.5–3 Wp)	26.08	27.30 (+5%)	6.14	51.29	Cash over-the-counter
Multi-Light & Mobile Charger	(3–11Wp)	88.00	83.67 (-5%)	16.67	247.03	PAYGo, 12 months
Entry-Level SHS	(11–21 Wp)	147.00	213.59 (+45%)	33.48	449.28	PAYGo, 18 months
Basic SHS	(21–50 Wp)	342.50	508.13 (+48%)	40.22	871.02	PAYGo, 18 months
Medium SHS	(50–100 Wp)	530.00	678.20 (+28%)	50.27	1,099.81	PAYGo, 18 months
High-Capacity SHS	(100+ Wp)	1,234.00	1,230.00 (-0%)	248.00	2,862.00	PAYGo, 18 months

Annex 5 - Methodology for Estimating Global OGS Market Value and Sales Volumes

To estimate global sales volumes and market turnover for off-grid solar kit sector, we use the following approach:

Step 1: Estimate the proportion of affiliate and non-affiliate off-grid solar energy kit (solar lanterns and multi-light systems, and SHS) sales by target countries where data is available

- Estimate total live products (solar lanterns and multi-light systems, and SHS) per target country using MTF data on solar panel wattage that categorizes household products into relevant product segments (note: 2022 analysis includes 3 new countries: Nigeria, Malawi, and Papua New Guinea)
- Estimate live affiliate solar kit products per market using data from GOGLA
- Compare live affiliate solar kit products to total live solar products to derive an estimated percent share of affiliate (and non-affiliate) products in each market
- Triangulate market share estimates in target countries with known sources for example, Ipsos reports, past MTR reports, and other secondary sources to sense-check outputs of analyses

Step 2: Scale up affiliate sales to global level and estimate market turnover using pricing data

- Calculate a global weighted average of affiliate versus non-affiliate market sales using affiliate sales across target countries, then use this global weighted average proportion to scale up total global affiliate sales to total global sales for solar kit market
- Estimate global market turnover using total global solar kit sales volumes multiplied by aggregate product pricing estimates across each of target market segmentation levels for example, solar lanterns and multi-light systems versus SHS, affiliate versus non-affiliate, and cash versus PAYGo

To estimate global sales volumes and market turnover for PUE market, we use a similar methodology to off-grid

solar kits with key modifications due to significant data limitations⁵²¹:

Step 1: Estimate proportion of affiliate and non-affiliate PUE market sales

- Due to significant data limitations, we have built off assumptions of affiliate vs. non-affiliate market proportions used in the 2019 State of the Off-Grid Market (SOGAM) report which analyzed global trends in the off-grid appliance sector and estimated affiliate sales account for between 20% and 50% of total off-grid appliance market sales
- These estimates have also been corroborated by key stakeholders engaged during consultations e.g. appliance manufacturers and distributors based in key countries in sub-Saharan Africa and Southeast Asia

Step 2: Estimate global proportion of affiliate and non-affiliate market split, scale up affiliate sales to global level and estimate market turnover using pricing research data

- Assuming a global non-affiliate appliance market split ranging between 50% and 80% respectively, scale up global affiliate appliance sales to total global appliance sales⁵²²
- Include additional scaling up assumptions to account for incompleteness and/or under-reporting of GOGLA affiliates appliance sales data⁵²³
- Estimate global appliance market turnover using resulting total global appliance sales volumes multiplied by pricing estimates across each of target segmentation levels for example, affiliate versus non-affiliate and cash versus PAYGo
- Conduct a sense-check of market sales estimates based on historical published off-grid appliance sector reports, key industry and stakeholder interviews, and existing firm sector expertise⁵²⁴

521 Note: Productive use of energy appliance market data is extremely limited compared to off-grid solar kits product category. The main sources of information used consisted of published reports available online including CLASP, VeraSol, GOGLA, internal firm knowledge as well as consultations held virtually at the convenience of those being interviewed. Key stakeholders approached for these consultations include: appliance manufacturers and distributors based in key countries in sub-Saharan Africa and Southeast Asia. The analysis and insights provided in this report thus reflects our collective understanding of key trends based on information available as at the time of writing.

522 [Efficiency for Access Coalition \(2019\), The State of the Off-Grid Appliance Market: Executive Summary.](#)

523 Open Capital Advisors analysis.

524 Note: the 2019 [The State of the Off-Grid Appliance Market](#) report estimated a historical 50-80% annual market growth rate for appliances as at 2019; based on this methodology and current assumptions, in the 2022 MTR, our analysis results in a 30% CAGR (annual growth rate) between 2018 and 2021, a marginally lower estimate that reflects slower market growth as a result of impacts of COVID-19 pandemic.

To derive pricing estimates for product pricing trends for the global OGS market, we used the following approach:

Step 1: Build a database of global prices

- Develop a pricing database with market-level product pricing data sourced from company websites, off-grid solar marketplaces e.g. mangoo.org, and other relevant sources of data including consultations, focusing primarily on data for major OGS markets in order to develop point and range estimates for product prices across each of the main product categories assessed in this report
- Populate the database with key information, including product brand/name, unit price, wattage, pricing by region (including both cash prices and PAYGo cost of ownership, as well as terms for example down payment where data is available

Step 2: Consolidate, analyze and conduct sensitivity checks on pricing data

- Aggregate pricing data in a consolidated dashboard using the captured dataset to identify pricing trends by product type (e.g., solar lanterns and multi-light

systems, SHS or key appliances e.g. solar water pumps), or by region e.g., Global, East or West Africa or East or South Asia

- Leverage consultations and internal firm expertise to validate derived price range estimates and cross-check insights with additional published market reports
- Note that the comparison of 2020 and 2022 prices is based on prices accessed from the sources named above at the time of writing the report; it is likely that some of the 2022 pricing data includes 2020 prices as companies haven't updated their databases and/or are unwilling to disclose latest prices
- IMPORTANT NOTE: These pricing estimates are indicative and nominal i.e. they are not adjusted for inflation. Based on our analysis of key inflation rates across key markets in sub-Saharan Africa and southeast Asia, we estimate an aggregate inflation rate of 6.58% which may have contributed to price increases between 2020 and 2022 in addition to the other factors outlined in the pricing section of the report



Annex 6 - Affiliate vs. Non-affiliate Live Products Distribution per Country

Figure 71: Estimated non-affiliate market share per MTF country (2021)

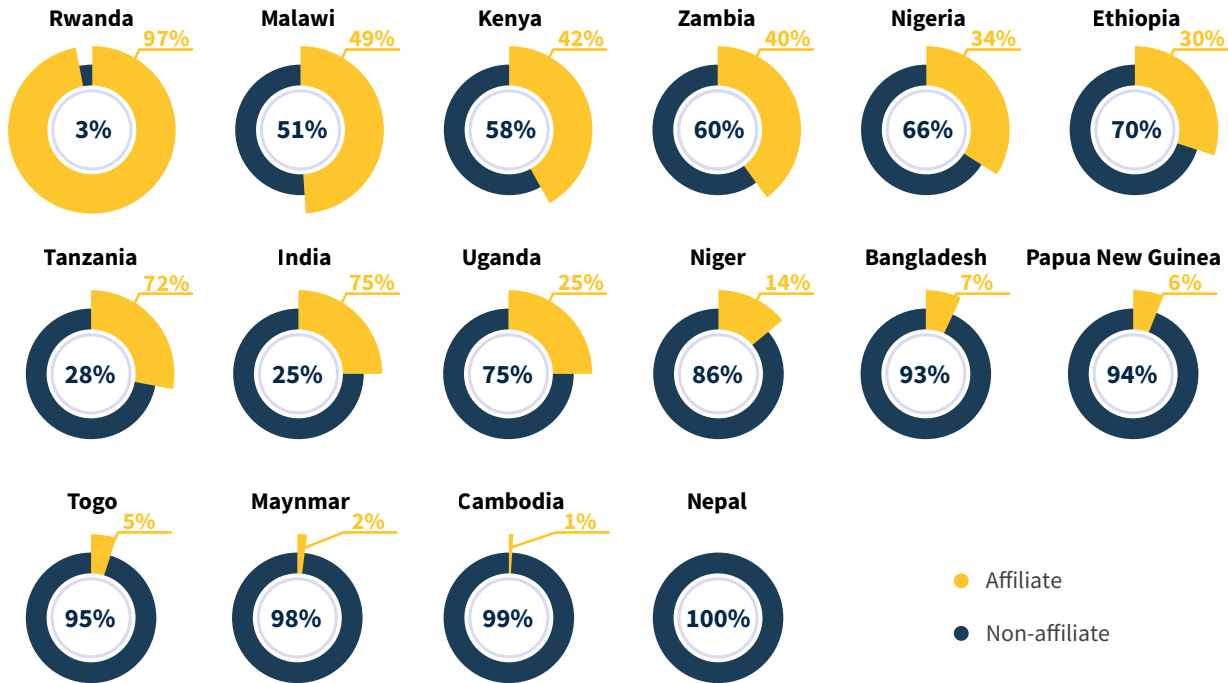

Annex 7 - Methodology for Estimating the PUE Demand Potential of Sub-Saharan Africa

To estimate the market potential for cooling solutions we use the following approach:

Step 1: Estimate the total potential market size for cold storage

- First estimate the number of rural smallholder farmer households which is 33 million for SSA then we estimate the number of smallholder farmer households across three key value chain segments in agriculture i.e. horticulture, dairy, and fish
- The underlying assumption here is that these three agricultural sectors have the most-demand for cooling services due to high-value, perishable produce
- We estimate the grid access of both rural and urban populations and use these estimates to exclude the segment of farmers with grid connection to derive the estimated number of smallholder farmers in the horticulture, dairy, and fish segments without access to the grid
- Next, we consider the number of farmers per unit to estimate the number of cold rooms needed for the smallholder farmers
- This estimate is then multiplied with the average cost of leading cold storage rooms in the region to get the total potential market

Step 2: Estimate the addressable market for productive use appliances focusing on the cold chain use case

- Once we have estimated the total potential market, we apply affordability constraints by deducting those that may be unable to afford the cooling solutions. We do this by estimating the % of smallholder farmers with the ability to access credit to purchase these solutions
- Next, using the number of potential cold rooms needed per smallholder farmer unit and applying affordability assumptions, we estimate the addressable market

To estimate the market potential for solar water pumps we use the following approach:

Step 1: Estimate the total potential market for irrigation pumps

- We begin by estimating the total population at a national level and the average population per household at a national level to estimate the total number of households
- We then determine the share of rural vs. urban households and estimate the number of rural smallholder farmer households as the target market for irrigation solutions
- Next, we deduct those with access to the grid to determine the number of rural smallholder farmer households with no access to the grid
- We consider the smallholder farmer households growing non-subsistence or cash crops as key targets for irrigation solutions
- Next, we consider smallholder farmer households growing non-subsistence crops with access to water to irrigate the land because this is a key factor for success using irrigation solutions and with that we get the total potential rural smallholder farmer market size

Step 2: Estimate the addressable market for solar irrigation pumps

- Once we have the total potential market, we apply the affordability constraints by estimating the total number of smallholder farmer households that can afford solar water pumps either through the amount of disposable income they have or the access to credit
- We then multiply the target number of smallholder farmer households that can afford the solar water pumps with the average solar water pump price to get the estimated addressable market

Annex 8 - Methodology for Estimating the PUE Demand Potential Of India

To estimate the market potential for cooling solutions we use the following approach:

Step 1: Estimate the total potential market size for cold storage

- First estimate the number of dairy smallholder farmer households in India which is 70 million. The assumption made is that the dairy segment of the agricultural sector in India has the highest demand for cooling services given its highly perishable nature
- We then estimate the number of dairy smallholder farmers in organized groups and those who are not part of organized groups. We conservatively assume that the unorganized dairy smallholder farmers have a higher cooling market potential as those in organized groups likely already have access to shared cooling services
- We then estimate the number of farmers per dairy cooperative and assess how many cold storage units are needed to meet average daily milk production potential
- This estimate is then multiplied with the average cost of the leading cold rooms in the country and region to estimate the total potential market

Step 2: Estimate the addressable market for productive use appliances for cold storage

- Once we have estimated the total potential market, we apply affordability constraints by estimating the % of smallholder farmers with the ability to access credit to acquire cold storage
- Using the number of potential cold storage rooms needed per smallholder farmer unit and applying the % of aggregators who can afford we estimate the addressable market

To estimate the market potential for solar water pumps we use the following approach:

Step 1: Estimate the total potential market size for solar irrigation pumps

- We begin with estimating the number of smallholder farmers in India and then move to estimating the number of smallholder farmers in rainfed areas
- We then estimate the number of smallholder farmers growing high priority/value crops that require irrigation
- Next we estimate the utilization rate of the solar water pumps, we multiply the number of smallholder farmers in rainfed areas growing high priority crops that require irrigation with the % of irrigation needs that can be fully met by solar water pumps
- This estimate is then multiplied with the average solar water pump price to estimate the potential market

Step 2: Estimate the addressable market for solar irrigation pumps

- Once we have the total potential market, we apply the affordability constraints by estimating the total number of smallholder farmer households that can be able to afford solar water pumps either through the amount of disposable income they have or the ability to access credit
- We then multiply the target number of smallholder farmer households that can afford the solar water pumps with the average solar water pump price with the government subsidy component to get the estimated addressable market



